



Goddard Space Flight Center  
Greenbelt, MD 20771

**GODDARD TECHNICAL  
STANDARD**

**GSFC-STD-7000B**

Approved: 04-28-2021  
Revalidation Date: 04-28-2027  
Superseding GSFC-STD-7000A

**General Environmental Verification Standard (GEVS)  
for GSFC Flight Programs and Projects**

**THIS STANDARD HAS BEEN REVIEWED FOR EXPORT CONTROL RESTRICTIONS;  
APPROVED FOR PUBLIC RELEASE  
DISTRIBUTION IS UNLIMITED**

## FOREWORD

This standard is published by the Goddard Space Flight Center (GSFC) to provide uniform engineering and technical requirements for processes, procedures, practices, and methods that have been endorsed as standard for NASA programs and projects, including requirements for selection, application, and design criteria of an item.

This standard provides guidelines for environmental verification programs for Goddard Space Flight Center (GSFC) payloads, subsystems and components and describes methods for implementing the environmental verifications described.

Requests for information, corrections, or additions to this standard should be submitted via “Contact Us” on the GSFC Technical Standards website at <http://standards.gsfc.nasa.gov>.

Original signed by:

---

Michael Viens  
Technical Standard Coordinator  
Goddard Space Flight Center

## **General Environmental Verification Standard (GEVS) For GSFC Flight Programs and Projects**

### **Approved By:**

Original signed by:

---

Tristram T. Hyde  
Chief Engineer  
Goddard Space Flight Center

Original signed by:

---

David F. Mitchell  
Director of Engineering and  
Technology  
Goddard Space Flight Center

Original signed by

---

Thomas V. McCarthy  
Director of Flight Projects  
Goddard Space Flight Center

Original signed by:

---

Eric K. Isaac  
Director of Safety and  
Mission Assurance  
Goddard Space Flight Center

NASA GODDARD SPACE FLIGHT CENTER  
Greenbelt, Maryland 20771

## DOCUMENT HISTORY LOG

### General Environmental Verification Standard

Change No.	Date	Nature of Change
Baseline	April 2005	
A	4/22/2013	Major update - STS references removed; Reference to Office of Mission Success removed; Added definition of anomaly; Significant updates to the following sections: 1.13; 2.2.5; 2.4.1.2; 2.4.1.4.1; 2.4.2.2; 2.4.2.6; 2.4.4.1; 2.4.4.2; 2.6.2.4; Section 1.14 added; Section 2.5 rewritten; Section 2.7 rewritten CCR Number CCR-D-0071
B	4/28/2021	Major Revision
B	4/24/2026	Administratively extended for one year.

## TABLE OF CONTENTS

Paragraph

### SECTION 1 – GENERAL INFORMATION

1.1	PURPOSE .....	1-1
1.2	APPLICABILITY AND LIMITATIONS .....	1-1
1.3	THE GSFC VERIFICATION APPROACH .....	1-1
1.4	OTHER ASSURANCE REQUIREMENTS.....	1-2
1.5	RESPONSIBILITY FOR ADMINISTRATION.....	1-2
1.6	GEVS CONFIGURATION CONTROL AND DISTRIBUTION .....	1-2
1.7	APPLICABLE DOCUMENTS .....	1-2
1.7.1	RF Compatibility Testing .....	1-3
1.7.2	Deep Space Network (DSN) Simulation .....	1-3
1.7.3	NASA Standards .....	1-3
1.7.4	Military Standards for EMI Testing.....	1-3
1.7.5	Military Standards for Non-Destructive Evaluation .....	1-3
1.8	DEFINITIONS .....	1-4
1.9	CRITERIA FOR UNSATISFACTORY PERFORMANCE .....	1-8
1.9.1	Failure Occurrence.....	1-8
1.9.2	Failures with Retroactive Effects .....	1-8
1.9.3	Failure Reporting.....	1-8
1.9.4	Wear Out.....	1-8
1.10	TEST SAFETY RESPONSIBILITIES .....	1-9
1.10.1	Operations Hazard Analysis, Responsibilities For .....	1-9
1.10.2	Treatment of Hazards.....	1-9
1.10.3	Facility Safety .....	1-9
1.10.4	Safety Responsibilities During Tests .....	1-10
1.11	TESTING OF SPARE HARDWARE.....	1-10
1.12	TEST FACILITIES, CALIBRATION .....	1-10
1.13	TEST CONDITION TOLERANCES.....	1-11
1.14	TEST MEASUREMENT CONSIDERATIONS .....	1-13

## **Section 2 - VERIFICATION PROGRAM**

### **SECTION 2.1 - SYSTEM PERFORMANCE VERIFICATION**

2.1	SYSTEM PERFORMANCE VERIFICATION.....	2.1-1
2.1.1	Documentation Requirements .....	2.1-1
2.1.1.1	System Performance Verification Plan.....	2.1-1
2.1.1.2	System Performance Verification Matrix .....	2.1-2
2.1.1.3	Environmental Verification Specification .....	2.1-3
2.1.1.4	Performance Verification Procedures.....	2.1-3
2.1.1.5	Verification Reports.....	2.1-3
2.1.1.6	System Performance Verification Report .....	2.1-3
2.1.1.7	Instrument Verification Documentation.....	2.1-4

### **SECTION 2.2 - ENVIRONMENTAL VERIFICATION**

2.2	APPLICABILITY.....	2.2-1
2.2.1	Test Sequence and Level of Assembly.....	2.2-1
2.2.2	Verification Program Tailoring .....	2.2-1
2.2.3	Qualification of Hardware by Similarity .....	2.2-3
2.2.4	Test Factors/Durations .....	2.2-4
2.2.5	Structural Analysis/Design Factors of Safety .....	2.2-4

### **SECTION 2.3 - ELECTRICAL FUNCTION & PERFORMANCE**

2.3	ELECTRICAL FUNCTION TEST REQUIREMENTS .....	2.3-1
2.3.1	Electrical Interface Tests .....	2.3-1
2.3.2	Comprehensive Performance Tests .....	2.3-1
2.3.3	Limited Performance Tests.....	2.3-1
2.3.4	Performance Operating Time and Failure-Free Performance Testing.....	2.3-2
2.3.5	Limited-Life Electrical Elements.....	2.3-2

### **SECTION 2.4 - STRUCTURAL AND MECHANICAL**

2.4	STRUCTURAL AND MECHANICAL VERIFICATION REQUIREMENTS .....	2.4-1
2.4.1	Structural Loads Qualification.....	2.4-1

2.4.1.1	Coupled load analysis.....	2.4-4
2.4.1.2	Modal Survey.....	2.4-6
2.4.1.3	Design Strength Qualification.....	2.4-7
2.4.1.4	Structural Reliability (Residual Strength Verification) .....	2.4-9
2.4.1.5	Acceptance Requirements .....	2.4-11
2.4.2	Vibroacoustic Qualification .....	2.4-12
2.4.2.1	Fatigue Life Considerations .....	2.4-14
2.4.2.2	Payload Acoustic Test .....	2.4-14
2.4.2.3	Payload Random Vibration Tests.....	2.4-15
2.4.2.4	Subsystem/Instrument Vibroacoustic Tests .....	2.4-16
2.4.2.5	Component/Unit Vibroacoustic Tests .....	2.4-16
2.4.2.6	Acceptance Requirements .....	2.4-18
2.4.2.7	Retest of Reflight Hardware .....	2.4-21
2.4.2.8	Retest of Reworked Hardware .....	2.4-21
2.4.3	Sinusoidal Sweep Vibration Qualification.....	2.4-21
2.4.3.1	ELV Payload Sine Sweep Vibration Tests.....	2.4-22
2.4.3.2	ELV Payload Subsystem and Component Sine Sweep Vibration Tests .....	2.4-23
2.4.3.3	Acceptance Requirements .....	2.4-25
2.4.4	Mechanical Shock Qualification.....	2.4-25
2.4.4.1	Subsystem Mechanical Shock Tests.....	2.4-25
2.4.4.2	Payload (Spacecraft) Mechanical Shock Tests .....	2.4-27
2.4.4.3	Acceptance Requirements .....	2.4-28
2.4.5	Mechanical Function Verification .....	2.4-28
2.4.5.1	Life Testing .....	2.4-28
2.4.5.2	Demonstration .....	2.4-31
2.4.5.3	Torque/Force Margin .....	2.4-35
2.4.5.4	Acceptance Requirements .....	2.4-36
2.4.6	Pressure Profile Qualification .....	2.4-37
2.4.6.1	Demonstration .....	2.4-37
2.4.6.2	Acceptance Requirements .....	2.4-37
2.4.7	Mass Properties Verification .....	2.4-37
2.4.7.1	Demonstration .....	2.4-38

2.4.7.2	Acceptance Requirements .....	2.4-39
---------	-------------------------------	--------

**SECTION 2.5 - EMC**

2.5	ELECTROMAGNETIC COMPATIBILITY (EMC) REQUIREMENTS .....	2.5-1
2.5.1.	General Requirements .....	2.5-1
2.5.1.1	Documentation.....	2.5-2
2.5.1.2	Requirements Overview.....	2.5-4
2.5.1.3	Testing at Lower Levels of Assembly.....	2.5-6
2.5.1.4	Safety and Controls .....	2.5-6
2.5.1.5	Test Facility and Procedure Requirements .....	2.5-6
2.5.1.6	Documentation Guidelines .....	2.5-12
2.5.2.	Detailed Requirements .....	2.5-19
2.5.2.1	Conducted Emissions Requirements .....	2.5-19
2.5.2.2	Conducted Susceptibility Requirements.....	2.5-30
2.5.2.3	Radiated Emissions Requirements .....	2.5-44
2.5.2.4	Radiated Susceptibility Requirements.....	2.5-46
2.5.2.5	System Level Requirements .....	2.5-49
2.5.3.	Application Guide .....	2.5-55
2.5.3.1	A Brief History of MIL-STD-461.....	2.5-56
2.5.3.2	Test Facility and Procedure Requirements .....	2.5-61
2.5.3.3	Detailed Requirements .....	2.5-69
2.5.3.4	Abbreviations, Acronyms, Constants, and Relations .....	2.5-149

**SECTION 2.6 - THERMAL**

2.6	THERMAL VERIFICATION TESTING – GENERAL.....	2.6-2
2.6.1	Definitions .....	2.6-2
2.6.2	General Requirements .....	2.6-5
2.6.2.1	Applicability.....	2.6-5
2.6.2.2	Level of Testing; Test Setup /Configuration .....	2.6-7
2.6.2.3	Special Considerations .....	2.6-9
2.6.2.4	Environment Simulation (General).....	2.6-11
2.6.2.5	Tailoring.....	2.6-14

2.6.3	THERMAL VACUUM VERIFICATION .....	2.6-14
2.6.3.1	Requirements .....	2.6-14
2.6.3.2	Test Parameters .....	2.6-15
2.6.3.3	Demonstration .....	2.6-20
2.6.3.4	Special Tests .....	2.6-23
2.6.3.5	Environment Simulation (TV) .....	2.6-23
2.6.3.6	Acceptance Requirements .....	2.6-23
2.6.4	THERMAL BALANCE VERIFICATION .....	2.6-24
2.6.4.1	Guidelines.....	2.6-24
2.6.4.2	Test Parameters .....	2.6-25
2.6.4.3	Demonstration .....	2.6-28
2.6.4.4	Special Tests .....	2.6-28
2.6.4.5	Acceptance Requirements .....	2.6-28
2.6.5	CONTAMINATION VERIFICATION.....	2.6-29
2.6.5.1	Temperature-Humidity Verification.....	2.6-31
2.6.6	LEAKAGE (INTEGRITY) VERIFICATION.....	2.6-332
2.6.6.1	Levels of Assembly .....	2.6-31
2.6.6.2	Demonstration .....	2.6-332
2.6.6.3	Acceptance Requirements .....	2.6-332

## SECTION 2.7 - CRYOGENICS

2.7	Cryogenic Philosophy .....	2.7-1
2.7.1	CRYOGENIC SYSTEMS VACUUM AND THERMAL VERIFICATION REQUIREMENTS .....	2.7-1
2.7.2	Summary of Requirements .....	2.7-1
2.7.3	Cryo-Thermal-Vacuum Qualification.....	2.7-2
2.7.3.1	Applicability.....	2.7-3
2.7.3.2	Special Considerations .....	2.7-4
2.7.3.3	Level of Testing .....	2.7-5
2.7.3.4	Test Parameters .....	2.7-5
2.7.3.5	Test Setup .....	2.7-8
2.7.3.6	Demonstration .....	2.7-8

2.7.3.7	Special Tests .....	2.7-10
2.7.3.8	Failure-Free-Performance.....	2.7-10
2.7.4	Thermal Balance Qualification.....	2.7-10
2.7.4.1	Alternative Methods .....	2.7-11
2.7.4.2	Use of a Thermal Analytical Model.....	2.7-11
2.7.4.3	Method of Cryo-Thermal Simulation.....	2.7-12
2.7.4.4	Internal Power.....	2.7-14
2.7.4.5	Special Considerations .....	2.7-14
2.7.4.6	Demonstration .....	2.7-14
2.7.4.7	Acceptance Requirements .....	2.7-15
2.7.5	Temperature-Humidity-Oxygen Deficiency Verification.....	2.7-15
2.7.5.1	Temperature-Humidity: Transportation and Storage .....	2.7-15
2.7.6	Leakage (Integrity Verification).....	2.7-16
2.7.6.1	Levels of Assembly .....	2.7-16
2.7.6.2	Demonstration .....	2.7-16
2.7.6.3	Acceptance Requirements .....	2.7-16

## **SECTION 2.8 - CONTAMINATION CONTROL**

2.8	Contamination and Coatings Engineering and Planetary Protection .....	2.8-1
2.8.1	Contamination .....	2.8-1
2.8.1.1	Summary of Contamination Verification Process .....	2.8-1
2.8.1.2	Contamination Engineering Approach.....	2.8-2
2.8.1.3	Contamination Sensitivities .....	2.8-5
2.8.1.4	Contamination Requirements.....	2.8-5
2.8.1.5	Contamination Budget .....	2.8-5
2.8.1.6	Contamination Control Plan (CCP) .....	2.8-6
2.8.1.7	Contamination Engineering During Design .....	2.8-7
2.8.1.8	Contamination Engineering Analyses .....	2.8-8
2.8.1.9	Contamination Engineering During Integration and Test.....	2.8-10
2.8.1.10	Thermal Vacuum Bakeouts.....	2.8-11
2.8.1.11	Spacecraft Transportation and Storage Phases.....	2.8-11
2.8.1.12	Launch Site Contamination Control.....	2.8-11

2.8.1.13	Launch Vehicle and Companion Payload Considerations .....	2.8-11
2.8.1.14	Launch and Orbit Insertion Mission Phases .....	2.8-12
2.8.1.15	On-Orbit Through End-of-Life Mission Phases.....	2.8-12
2.8.1.16	Spacecraft Post-Mission and Follow-on Program Phases.....	2.8-14
2.8.2	Coatings Engineering .....	2.8-15
2.8.2.1	Key Verification Milestones for Coatings Selections and Testing .....	2.8-16
2.8.3	Planetary Protection .....	2.8-16
2.8.3.1	Classification of Missions .....	2.8-17
2.8.3.2	Planetary Protection Categorization of Missions .....	2.8-17
2.8.3.3	Planetary Protection Plan Development (Categories II-V).....	2.8-18
2.8.3.4	Measurements and Verification.....	2.8-19
2.8.3.5	Documentation for Planetary Protection Requirements and Verification.....	2.8-19

## **SECTION 2.9 - END-TO-END TESTING**

2.9	END-TO-END COMPATIBILITY TESTS AND SIMULATIONS.....	2.9-1
2.9.1	Compatibility Tests .....	2.9-1
2.9.2	Mission Simulations.....	2.9-1
<b>Appendix A – General Information .....</b>		<b>A-1</b>
<b>Appendix B - Environmental Verification for CubeSats Companion to GSFC-STD-7000 (General Environmental Verification Standard) .....</b>		<b>B-1</b>

## Tables

Table	
2.2-1	Flight System Hardware Levels of Assembly ..... 2.2-3
2.2-2	Test Factors/Durations ..... 2.2-5
2.2-3	Flight Hardware Design/Analysis Factors of Safety Applied to Limit Loads ..... 2.2-6
2.4-1	Structural and Mechanical Verification Test Requirements ..... 2.4-2
2.4-2	Minimum Probability-Level Requirements for Flight Limit (maximum expected) Level ..... 2.4-3
2.4-3	Generalized Random Vibration Test Levels, Components. .... 2.4-19
2.4-4	Component Minimum Workmanship Random Vibration Test Levels ..... 2.4-20
2.5-1	Susceptibility Scanning (Replacement for MIL-STD-461F Table III) ..... 2.5-9
2.5-2	EMI Requirements Summary ..... 2.5-18
2.6-1	Thermal Vacuum Verification Summary (non-cryogenic) ..... 2.6-17
2.7-1	Cryogenic Vacuum, Thermal, Electrical and Mechanical Requirements ..... 2.7-2
2.7-2	Margins As A Function Of Phase in Project Life-Cycle ..... 2.7-6
A-1	Acoustic Fill-Factor, 3 meter Payload Fairing ..... A-2

## FIGURES

Figure	
2.1-1	Environmental Test Matrix ..... 2.1-5
2.1-2a	Verification Test Report..... 2.1-6
2.1-2b	Verification Test Report (continued)..... 2.1-7
2.4-1	Shock Response Level (SRS) – for Assessing Component Test Requirements..... 2.4-27
2.5-1	Capacitor Network Simulating Battery Dominated Bus Impedance ..... 2.5-8
2.5-2	General Test Setup Diagram ..... 2.5-11
2.5-3	General Test Setup For Free Standing EUT in Shielded Enclosure..... 2.5-12

2.5-4	Conducted Emissions Test Set-Up (Schematic) Differential Mode .....	2.5-20
2.5-5	Conducted Emissions Test Set-Up (Physical Layout) Differential Mode .....	2.5-20
2.5-6	Conducted Emissions Differential Mode Limits.....	2.5-21
2.5-7	Common Mode Conducted Emissions Default Limit.....	2.5-22
2.5-8	CMCE Test Setup, Modified CE101/CE03 Test Methods, Power Leads .....	2.5-24
2.5-9	CMCE Test Setup, Modified CE101/CE03 Test Methods, Signal Cables .....	2.5-22
2.5-10	CMCE Test Setup, Absorbing Clamp Method .....	2.5-25
2.5-11	Inrush Current Transient Default Limit .....	2.5-27
2.5-12	Inrush Current Emissions Test Setup (Current Probe) .....	2.5-29
2.5-13	Inrush Current Emissions Alternate Test Setup (Series Resistor).....	2.5-29
2.5-14	Conducted Susceptibility Voltage Limit (30 Hz to 150 kHz).....	2.5-31
2.5-15	Conducted Susceptibility Power Limit (30 Hz to 150 kHz).....	2.5-31
2.5-16	General CS101 Test Setup .....	2.5-32
2.5-17	Alternate CS101 Test Method With Direct Current Monitoring .....	2.5-32
2.5-18	Conducted Susceptibility Transient Waveform .....	2.5-34
2.5-19	Conducted Transient Susceptibility Test Setup .....	2.5-34
2.5-20	Conducted Transient Susceptibility Test Setup – Parallel Injection.....	2.5-35
2.5-21	Common Mode Conducted Susceptibility Current Limits.....	2.5-37
2.5-22	Conducted Susceptibility, Power Leads, 150 kHz to 50 MHz Voltage Limit.....	2.5-39
2.5-23	Conducted Susceptibility, Power Leads, 150 kHz to 50 MHz Current Limits .....	2.5-39
2.5-24	Conducted Susceptibility, Power Leads Test Setup .....	2.5-40
2.5-25	Conducted Susceptibility, Power Leads Test Setup, Alternate Method.....	2.5-41
2.5-26	CS115 Default Limit .....	2.5-42
2.5-27	Radiated Emissions Electric Field Limit with Suggested Notches .....	2.5-45
2.5-28	Recommended Test Setup, Instrument/Payload Level Power Quality Measurements ...	2.5-50
2.5-29	Recommended Test Setup, Spacecraft/Observatory Level Power Quality Measure .....	2.5-50

2.5-30	Impacts of Uncontrolled EGSE Common Mode Currents.....	2.5-61
2.5-31	Proper EGSE Shielding and Grounding Configuration .....	2.5-61
2.5-32	EGSE Cable Shield Termination – Connector Break (Preferred Method) .....	2.5-63
2.5-33	EGSE Cable Shield Termination – Stuffing Tube (Alternate Method) .....	2.5-63
2.5-34	Common Source Impedance and Harness Impedance .....	2.5-65
2.5-35	Power Distribution Wiring, Large Military Platforms (Worst Case) .....	2.5-66
2.5-36	Power Distribution Wiring, GSFC Platforms (Typical).....	2.5-66
2.5-37	Capacitor Network Simulating Battery Dominated Bus.....	2.5-67
2.5-38	Conducted Emissions Set-Up Single-Ended .....	2.5-70
2.5-39	Basic Common Mode Conducted Emissions Calibration Setup .....	2.5-73
2.5-40	Nominal Transfer Impedance of CISPR 16 Absorbing Clamp .....	2.5-73
2.5-41	Elemental Electric Dipole Model .....	2.5-76
2.5-42	Simplified Inductive Crosstalk Model .....	2.5-77
2.5-43	General Transmission Line Model .....	2.5-78
2.5-44	Current Amplitude vs Position, DC to $l = \lambda/4$ .....	2.5-79
2.5-45	Current Amplitude vs. Position, $l = \lambda/4$ to $l = \lambda/2$ .....	2.5-79
2.5-46	Current Amplitude vs. Position, $l = \lambda/2$ to $l = 3\lambda/4$ .....	2.5-80
2.5-47	Current Amplitude vs. Position, $l = 3\lambda/4$ to $l = \lambda$ .....	2.5-80
2.5-48	Source End Current vs. $l/\lambda$ for Mismatched Transmission Line .....	2.5-81
2.5-49	Currents at Various Locations on Mismatched Transmission Line .....	2.5-82
2.5-50	Effect of Damping Impedance on Null at $l = \lambda/4$ .....	2.5-84
2.5-51	Effect of Damping Impedance on Peak at $l = \lambda/2$ .....	2.5-84
2.5-52	“Snapshot in Time” for Maximum Field Cancellation .....	2.5-86
2.5-53	“Snapshot in Time” for Maximum Coupling.....	2.5-86
2.5-54	Damping at “Snapshot in Time” for Maximum Field Cancellation.....	2.5-87
2.5-55	Damping at “Snapshot in Time” for Maximum Coupling .....	2.5-87

2.5-56	Current Measurement Fixture .....	2.5-90
2.5-57	Measured Current with Standard Current Probe .....	2.5-92
2.5-58	Example Measured Currents With and Without Absorbing Clamp .....	2.5-92
2.5-59	Solid State Switch Example Design .....	2.5-94
2.5-60	Measurement System Check (Current Probe).....	2.5-95
2.6-61	Measurement System Check (Series Resistor).....	2.5-95
2.5-62	Inrush Current Calibration Waveform.....	2.5-96
2.5-63	Input Power Voltage Sag Measurement Setup .....	2.5-96
2.5-64	CS01/CS101 Pre-Calibration Setup.....	2.5-102
2.5-65	CS101 Pre-Calibration Equivalent Circuit, Transformer Included.....	2.5-103
2.5-66	CS101 Pre-Calibration Equivalent Circuit, Referred to Transformer Secondary .....	2.5-103
2.5-67	Conducted Susceptibility Alternate Test Setup (Differential Mode, 30 Hz to 150 kHz) .	2.5-105
2.5-68	CS101 Alternate Voltage Limit .....	2.5-106
2.5-69	CS101 Alternate Power Limit .....	2.5-106
2.5-70	Plane Electromagnetic Wave Impinging On Wire-Above-Ground .....	2.5-110
2.5-71	$V/E$ for Wire Above Ground, $h = 5$ cm.....	2.5-111
2.5-72	$I_{\infty}/E_0$ into 100 $\Omega$ CS114 Calibration Fixture .....	2.5-112
2.5-73	$I/E_0$ with Precalibrated Levels Applied to Shorted 50 $\Omega$ Line .....	2.5-114
2.5-74	$(I/E_0)_{MAX}$ per MIL-STD-461F and MIL-STD-461G .....	2.5-114
2.5-75	Simplified CS114 Calibration Diagram.....	2.5-115
2.5-76	CS114 Pre-Calibration Equivalent Circuit .....	2.5-116
2.5-77	Thévenin Equivalent Circuit for CUT Injection .....	2.5-118
2.5-78	Representative $Z_S$ for $N = 1$ and $N = 2$ .....	2.5-118
2.5-79	Representative $(V_{emf})_{OC}$ for $N = 1$ and $N = 2$ .....	2.5-119
2.5-80	Representative $I_{SC}$ for $N = 1$ and $N = 2$ .....	2.5-120
2.5-81	Representative $(V_{emf})_{OC}$ for $N = 1$ and $N = 2$ .....	2.5-122

2.5-82	Representative $I_{SC}$ for $N = 1$ and $N = 2$ .....	2.5-122
2.5-83	RE “Spot Size” Calculation .....	2.5-127
2.5-84	Side and Back Lobe Antenna Factor .....	2.5-129
2.5-85	Theoretical Noise Floor Limits Considering Average Thermal Power .....	2.5-130
2.5-86	Typical Antenna Factors for Measurement Antennas .....	2.5-132
2.5-87	Theoretical Floor Limits for Measurement System Using Peak Thermal Power .....	2.5-133
2.5-88	Measurement Bandwidth and Clock Jitter .....	2.5-134
2.5-89	Probability Density of Thermal Voltage Noise .....	2.5-136
2.5-90	MIL-STD-461G CS114 Calibration Limits .....	2.5-145
2.5-91	Inductance Per Unit Length, Wire Above Ground .....	2.5-147
2.5-92	Capacitance Per Unit Length, Wire Above Ground .....	2.5-147
2.5-93	Characteristic Impedance, Wire Above Ground .....	2.5-148
2.6-1	Thermal-Vac Test Temperature Margins (Passive Thermal Control) .....	2.6-16
2.6-2	Notional TV Test Temperature Profiles .....	2.6-23
2.6-3	Temperature-Humidity Profile for Descent and Landing Demonstration .....	2.6-32
2.8-1	Contamination Engineering Approach .....	2.8-4
A-1	Cylindrical Payload in Fairing Acoustic Fill-Factor .....	A-1
A-2	Acoustic Fill-Factor for Various Size Payloads in a 3 Meter Diameter Payload Fairing .....	A-3
A-3	Determination of Qualification and Acceptance Random Vibration Test Levels .....	A-4
A-4	Shock Environment Produced by Linear Pyrotechnic Devices .....	A-7
A-5	Shock Environment Produced by Separation Nuts and Explosive Bolts .....	A-8
A-6	Shock Environment Produced by Pin-Pullers and Pin-Pushers .....	A-9
A-7	Shock Environment Produced by Bolt-Cutters, Pin-Cutters, and Cable-Cutters .....	A-10
A-8	Attenuation of Constant Velocity Line .....	A-11
A-9	Peak Pyrotechnic Shock Response vs. Distance .....	A-12
A-10	Shock Attenuation Example .....	A-13

GSFC-STD-7000B  
04/28/2021  
Supersedes  
GSFC-STD-7000A

A-11      Reduction of Pyrotechnic Shock Response due to Intervening Structure .....A-14

## **SECTION I**

### **GENERAL INFORMATION**

## 1.1 PURPOSE

This standard provides guidelines for environmental verification programs for Goddard Space Flight Center (GSFC) payloads, subsystems and components and describes methods for implementing the environmental verifications described. It contains a baseline for demonstrating, by test and/or analysis, the satisfactory performance of hardware in the expected mission environments, and that minimum workmanship standards have been met. It elaborates on those guidelines, gives guideline test levels, provides guidance in the choice of test options, and describes acceptable test and analytical methods for implementing the requirements. It is expected that projects will use this handbook in the development of their environmental requirements. Any guidelines that are intended as “institutional” requirements will be captured in GSFC-Std-1000 Rules for the Design, Development, and Operation of Flight Systems (also known as the GOLD Rules).

These guidelines are intended for use by GSFC projects and contractors and can be tailored to create a project specific verification plan and verification specification as discussed in section 2.1. GSFC projects should select from the options to fulfill the specific payload (spacecraft) requirements in accordance with the launch vehicle to be used, or to cover other mission-specific considerations.

## 1.2 APPLICABILITY AND LIMITATIONS

These guidelines apply to GSFC hardware and associated software that is to be launched on an Expendable Launch Vehicle (ELV). Hardware launched by balloons, sounding rockets or aircraft is not included. The guidelines apply to the following:

- a. All space flight hardware, including interface hardware, that is developed as part of a payload managed by GSFC, whether developed by (1) GSFC or any of its contractors, (2) another National Aeronautics and Space Administration (NASA) center, or (3) an independent agency; and
- b. All space flight hardware, including interface hardware that is developed by GSFC or any of its contractors and that is provided to another NASA installation or independent agency as part of a payload that is not managed by GSFC.

The provisions herein are generally limited to the verification of ELV payloads and to those activities (with emphasis on the environmental verification program) that are closely associated with such verification, such as workmanship and functional testing.

GEVS is written in accordance with the current GSFC practice of using a single protoflight payload for both qualification testing and space flight (see definition of hardware, 1.8). The protoflight verification program, therefore, is given as the nominal test program.

## 1.3 THE GSFC VERIFICATION APPROACH

Goddard Space Flight Center endorses the full systems verification approach in which the entire payload is tested or verified under conditions that simulate the flight operations and flight environment as realistically as possible. GEVS is written in accordance with that view. However, it is recognized that there may be unavoidable exceptions, or conditions which make it preferable to perform the verification activities at lower levels of assembly. For example, testing at lower levels of assembly may be necessary to produce sufficient environmentally induced stresses to uncover design and workmanship flaws. These test requirements should

be tailored for each specific space program and waivers to GSFC-STD-1000 should be submitted where tailoring results in test activity that doesn't meet the requirements in GSFC-STD-1000.

Since testing at the component (or unit) level, or lower level of assembly for large components, often becomes a primary part of the verification program, all components should be operating and monitored during all environmental tests if practicable.

Environmental verification of hardware is only a portion of the total assurance effort at GSFC that establishes confidence that a payload will function correctly and fly a successful mission. The environmental test program provides confidence that the design will perform when subjected to mission environments since the test environments are more severe than expected during the mission. The environmental test program also provides environmental stress screening to uncover workmanship defects.

The total verification process also includes the development of models representing the hardware, tests to validate or correlate the models, analyses, alignments, calibrations, functional/performance tests to verify proper operation, and finally end-to-end tests and simulations to show that the total system will perform as specified.

Other tests not included herein may be performed as required by the project. The level, procedure, and decision criteria for performing any such additional tests should be included in the system verification plan and system verification specification (section 2.1).

#### 1.4 OTHER ASSURANCE REQUIREMENTS

In addition to the verification program, the assurance effort includes parts and materials selection and control, reliability assessments, quality assurance, software assurance, design reviews, and system safety.

#### 1.5 RESPONSIBILITY FOR ADMINISTRATION

The responsibility and authority for decisions in applying the guidelines of this standard rest with the project manager. The general/environmental guidelines are intended for use by the flight project managers, assisted by the systems assurance managers, and systems engineering in developing project-unique performance verification requirements, plans, and specifications that are consistent with current NASA program/project planning.

#### 1.6 GEVS CONFIGURATION CONTROL AND DISTRIBUTION

This document is controlled and maintained by the GSFC Technical Standards Program and is available through the Goddard Document Management System (GDMS).

#### 1.7 APPLICABLE DOCUMENTS

The following documents may be needed in formulating the environmental test program. The user must ensure that the latest versions are procured and that the most recent changes and additions are included.

### 1.7.1 RF Compatibility Testing

450-PROC-CTP/SN/NEN; Radio Frequency (RF) Compatibility Test Procedures between Spacecraft and the Space Network (SN) and/or Near Earth Network (NEN), Revision 2; Effective Date: April 7, 2016

### 1.7.2 Deep Space Network (DSN) Simulation

The Deep Space Network/Flight Project Interface Design Handbook, 810-5, Jet Propulsion Laboratory, California Institute of Technology, Vol. I, Module TSS-10, describes existing payload (spacecraft) telemetry and command simulation capability. Vol. II describes proposed DSN capability

### 1.7.3 NASA Standards

The following standards provide supporting information:

- a. NASA-STD 7002, Payload Test Requirements
- b. NASA-STD-7001, Payload Vibroacoustic Test Criteria
- c. NASA-STD-7003, Pyroshock Test Criteria
- d. NASA-HDBK-7004, Force Limited Vibration Testing
- e. NASA-HDBK-7005, Dynamic Environmental Criteria
- f. NASA-STD-5001, Structural Design and Test Factors of Safety for Space Flight Hardware
- g. NASA-STD-5002, Load Analyses of Spacecraft and Payloads
- h. NASA-STD-5009, Nondestructive Evaluation Requirements for Fracture Critical Metallic Components
- i. NASA-STD-5019, Fracture Control Requirements for Spaceflight Hardware
- j. GSFC-STD-1000, Rules for Design, Development and Operation of Flight Systems

### 1.7.4 Military Standards for EMI Testing

Pertinent sections of the following standards are needed to conduct the EMI tests:

- a. MIL-STD-461, Requirements for the Control of Electromagnetic Interference Characteristics of Subsystems and Equipment, December 2015

Additional documentation is specified in Section 2.5.

### 1.7.5 Military Standards for Non-Destructive Evaluation

- a. MIL-HDBK-6870, Inspection Program Requirements, Non-Destructive Testing for Aircraft and Missile Materials and Parts.

- b. NAS-410, Certification and Qualification of Nondestructive Test Personnel.
- c. MSFC-STD-1249, Standard NDE Guidelines and Requirements for Fracture Control Programs.
- d. MIL-HDBK-728, Nondestructive Testing.

## 1.8 DEFINITIONS

The following definitions apply within the context of this specification:

**Acceptance Tests:** The verification process that demonstrates that hardware is acceptable for flight. It also serves as a quality control screen to detect deficiencies and, normally, to provide the basis for delivery of an item under terms of a contract.

**Anomaly:** An unexpected event that is outside of design/performance specification limits or is inconsistent with proper system behavior. NOTE: Design limits are those identified in approved design-level documents.

**Assembly:** See Level of Assembly.

**Component:** See Level of Assembly.

**Configuration:** The functional and physical characteristics of the payload and all its integral parts, assemblies and systems that are capable of fulfilling the fit, form and functional requirements defined by performance specifications and engineering drawings.

**Contamination:** The presence of materials of molecular or particulate nature which degrade the performance of hardware.

**Design Qualification Tests:** Tests intended to demonstrate that the test item will function within performance specifications under simulated conditions more severe than those expected from ground handling, launch, and mission operations. Their purpose is to uncover deficiencies in design and method of manufacture. They are not intended to exceed design safety margins or to introduce unrealistic modes of failure. The design qualification tests may be to either "prototype" or "protoflight" test levels.

**Design Specification:** Generic designation for a specification that describes functional and physical requirements for an article, usually at the component level or higher levels of assembly. In its initial form, the design specification is a statement of functional requirements with only general coverage of physical and test requirements. The design specification evolves through the project life cycle to reflect progressive refinements in performance, design, configuration, and test requirements. In many projects the end-item specifications serve all the purposes of design specifications for the contract end-items. Design specifications provide the basis for technical and engineering management control.

**Electromagnetic Compatibility (EMC):** The condition that prevails when various electronic devices are performing their functions according to design in a common electromagnetic environment.

**Electromagnetic Interference (EMI):** Electromagnetic energy which interrupts, obstructs, or otherwise degrades or limits the effective performance of electrical equipment.

Electromagnetic Susceptibility: Undesired response by a component, subsystem, or system to conducted or radiated electromagnetic emissions.

End-to-End Tests: Tests performed on the integrated ground and flight system, including all elements of the payload, its control, stimulation, communications, and data processing to demonstrate that the entire system is operating in a manner to fulfill all mission requirements and objectives.

Failure: A departure from specification that is discovered in the functioning or operation of the hardware or software. See nonconformance.

Flight Acceptance: See Acceptance Tests.

Fracture Control Program: A systematic project activity to ensure that a payload intended for flight has sufficient structural integrity as to present no critical or catastrophic hazard as well as to ensure quality of performance in the structural area for any payload (spacecraft) project. Central to the program is fracture control analysis, which includes the concepts of fail-safe and safe-life, defined as follows:

- a. Fail-safe: Ensures that a structural element, because of structural redundancy, will not cause collapse of the remaining structure or have any detrimental effects on mission performance.
- b. Safe-life: Ensures that the largest flaw that could remain undetected after non-destructive examination would not grow to failure during the mission.

Functional Tests: The operation of a unit in accordance with a defined operational procedure to determine whether performance is within the specified requirements.

Hardware: As used in this document, there are two major categories of hardware as follows:

- a. Prototype Hardware: Hardware of a new design; it is subject to a design qualification test program; it is not intended for flight.
- b. Flight Hardware: Hardware to be used operationally in space. It includes the following subsets:
  - (1) Protoflight Hardware: Flight hardware of a new design; it is subject to a qualification test program that combines elements of prototype and flight acceptance verification; that is, the application of design qualification test levels and flight acceptance test durations.
  - (2) Follow-On Hardware: Flight hardware built in accordance with a design that has been qualified either as prototype or as protoflight hardware; follow-on hardware is subject to a flight acceptance test program.
  - (3) Spare Hardware: Hardware the design of which has been proven in a design qualification test program; it is subject to a flight acceptance test program and is used to replace flight hardware that is no longer acceptable for flight.
  - (4) Reflight Hardware: Flight hardware that has been used operationally in space and is to be reused in the same way; the verification program to which it is subject depends on its past performance, current status, and the upcoming mission.

Level of Assembly: The environmental test guidelines of GEVS generally start at the component or unit level assembly and continue through the system level (referred to in GEVS as the payload or spacecraft level). The assurance program includes the part level. Verification testing may also include testing at the assembly and subassembly levels of assembly; for test record keeping, these levels are combined into a "subassembly" level. The verification program continues through launch, and on-orbit performance. The following levels of assembly are used for describing test and analysis configurations:

**Assembly:** A functional subdivision of a component consisting of parts or subassemblies that perform functions necessary for the operation of the component as a whole. Examples are a power amplifier and gyroscope.

**Component:** A functional subdivision of a subsystem and generally a self-contained combination of items performing a function necessary for the subsystem's operation. Examples are electronic box, transmitter, gyro package, actuator, motor, battery. For the purposes of this document, "component" and "unit" are used interchangeably.

**Instrument:** A spacecraft subsystem consisting of sensors and associated hardware for making measurements or observations in space. For the purposes of this document, an instrument is considered a subsystem (of the spacecraft).

**Module:** A major subdivision of the payload that is viewed as a physical and functional entity for the purposes of analysis, manufacturing, testing, and recordkeeping. Examples include spacecraft bus, science payload, and upper stage vehicle.

**Part:** A hardware element that is not normally subject to further subdivision or disassembly without destruction of design use. Examples include resistor, integrated circuit, relay, connector, bolt, and gaskets.

**Payload:** An integrated assemblage of modules, subsystems, etc., designed to perform a specified mission in space. For the purposes of this document, "payload" and "spacecraft" are used interchangeably. Other terms used to designate this level of assembly are Laboratory, Observatory, Satellite and System Segment.

**Spacecraft:** See Payload. Other terms used to designate this level of assembly are Laboratory, Observatory, and Satellite.

**Section:** A structurally integrated set of components and integrating hardware that form a subdivision of a subsystem, module, etc. A section forms a testable level of assembly, such as components/units mounted into a structural mounting tray or panel-like assembly, or components that are stacked.

**Subassembly:** A subdivision of an assembly. Examples are wire harness and loaded printed circuit boards.

**Subsystem:** A functional subdivision of a payload consisting of two or more components. Examples are structural, attitude control, electrical power, and communication subsystems. The science instruments or experiments are also included as subsystems of the payload.

**Unit:** A functional subdivision of a subsystem, or instrument, and generally a self-contained combination of items performing a function necessary for the subsystem's operation. Examples are electronic box, transmitter, gyro package, actuator, motor,

battery. For the purposes of this document, "component" and "unit" are used interchangeably.

Limit Level: The maximum expected flight level (consistent with the minimum probability levels of Table 2.4-2).

Margin: The amount by which hardware capability exceeds requirements.

Module: See Level of Assembly.

Nonconformance: A condition of any hardware, software, material, or service in which one or more characteristics do not conform to specified requirements.

Offgassing: The emanation of volatile matter of any kind from materials into a crewed pressurized volume.

Outgassing: The emanation of volatile materials under vacuum conditions resulting in a mass loss and/or material condensation on nearby surfaces.

Part: See Level of Assembly.

Payload: See Level of Assembly.

Performance Verification: Determination by test, analysis, or a combination of the two that the payload element can operate as intended in a particular mission; this includes being satisfied that the design of the payload or element has been qualified and that the particular item has been accepted as true to the design and ready for flight operations.

Protoflight Testing: See Hardware.

Prototype Testing: See Hardware.

Qualification: See Design Qualification Tests.

Redundancy (of design): The use of more than one independent means of accomplishing a given function.

Section: See Level of Assembly.

Spacecraft: See Level of Assembly.

Subassembly: See Level of Assembly.

Subsystem: See Level of Assembly.

Temperature Cycle: A transition from some initial temperature condition to temperature stabilization at one extreme and then to temperature stabilization at the opposite extreme and returning to the initial temperature condition.

Temperature Stabilization: The condition that exists when the rate of change of temperatures has decreased to the point where the test item may be expected to remain within the specified test tolerance for the necessary duration or where further change is considered acceptable.

**Thermal Balance Test:** A test conducted to verify the adequacy of the thermal model, the adequacy of the thermal design, and the capability of the thermal control system to maintain thermal conditions within established mission limits.

**Thermal-Vacuum Test:** A test conducted to demonstrate the capability of the test item to operate satisfactorily in vacuum at temperatures based on those expected for the mission. The test, including the gradient shifts induced by cycling between temperature extremes, can also uncover latent defects in design, parts, and workmanship.

**Unit:** See Level of Assembly.

**Vibroacoustics:** An environment induced by high-intensity acoustic noise associated with various segments of the flight profile; it manifests itself throughout the payload in the form of directly transmitted acoustic excitation and as structure-borne random vibration.

**Workmanship Tests:** Tests performed during the environmental verification program to verify adequate workmanship in the construction of a test item. It is often necessary to impose stresses beyond those predicted for the mission in order to uncover defects. Thus random vibration tests are conducted specifically to detect bad solder joints, loose or missing fasteners, improperly mounted parts, etc. Cycling between temperature extremes during thermal-vacuum testing and the presence of electromagnetic interference during EMC testing can also reveal the lack of proper construction and adequate workmanship.

## 1.9 CRITERIA FOR UNSATISFACTORY PERFORMANCE

Deterioration or any change in performance of any test item that does or could in any manner prevent the item from meeting its functional, operational, or design requirements throughout its mission should be reason to consider the test item as having failed. Other factors concerning failure are considered in the following paragraphs.

### 1.9.1 Failure Occurrence

When a failure (non-conformance or trend indicating that an out of spec condition will result) occurs, a determination should be made as to the feasibility and value of continuing the test to its specified conclusion. If corrective action is taken, the test should be repeated to the extent necessary to demonstrate that the test item's performance is satisfactory.

### 1.9.2 Failures with Retroactive Effects

If corrective action taken as a result of failure, e.g. redesign of a component, affects the validity of previously completed tests, prior tests should be repeated to the extent necessary to demonstrate satisfactory performance.

### 1.9.3 Failure Reporting

Every failure should be recorded and reported in accordance with the failure reporting provisions of the project.

### 1.9.4 Wear Out

If during a test sequence a test item is operated in excess of design life and wears out or becomes unsuitable for further testing from causes other than deficiencies, a spare may be substituted. If, however, the substitution affects the significance of test results, the test during

which the item was replaced and any previously completed tests that are affected should be repeated to the extent necessary to demonstrate satisfactory performance.

## 1.10 TEST SAFETY RESPONSIBILITIES

The following paragraphs define the responsibilities shared by the space project and facility management for planning and enforcing industrial safety measures taken during testing for the protection of personnel, the payload, and the test facility.

### 1.10.1 Operations Hazard Analysis, Responsibilities For

It will be the joint responsibility of the test facility manager and the project manager to ensure that environmental tests and associated operations do not present unacceptable hazard(s) to the test item, facilities, or personnel. A test operations hazard analysis (OHA) will be performed by the facility and project personnel to consider and evaluate all hazards presented by the interaction of the payload and the facility for each environmental test. All hazards discovered in the OHA will be tracked to an agreed-upon resolution. The safety measures to be taken as a result of the OHA, as well as the safety measures between tests, will be specified as requirements in the verification plan and verification specification. (sec. 2.1.1)

### 1.10.2 Treatment of Hazards

As hazards are discovered, they will be mitigated using the hierarchy of hazard controls: elimination, substitution, engineering, administrative and personal protective equipment. Elimination is when the hazard is physically removed and no longer present. Substitution is replacing something that produces a hazard with something that does not produce a hazard. An example is replacing a hazardous chemical with a nonhazardous chemical. Engineering controls do not eliminate hazards, but rather isolate people from the hazards. Examples include: installation of a fume hood to remove airborne contaminants, construction of a platform to address work at heights hazards. Administrative controls are changes to the way people work to limit or prevent personnel exposure to hazards. Examples include procedure changes, employee training, and installation of signs and warning labels. Personal protective equipment (PPE) should be used as a last resort and only with training that stresses the importance of the proper use of the equipment. Examples of PPE include safety shoes, fall protection harnesses, safety glasses, etc. In practice, a combination of all five methods may be the best solution to the hazards posed by a complex system. Before any test begins, the project manager and test facility management will agree on the hazard control method(s) that are to be used.

### 1.10.3 Facility Safety

The test facility manager will verify that the test facility and normal operations present no unacceptable hazard to the test item, test and support equipment, or personnel. He/she will ensure that facility personnel abide by all applicable regulations, observe all appropriate industrial safety measures, and follow all requirements for protective equipment. He/she will ensure that all facility personnel are trained and qualified for their positions. Training should include the handling of emergencies by the simulation of emergency conditions. Analyses, tests, and inspections will be performed to verify that the safety requirements are satisfied. The approach outlined in 1.10.2 will be used to mitigate hazards.

#### 1.10.4 Safety Responsibilities During Tests

The test facility manager will appoint a safety officer to work closely with a safety officer designated by the space project. The facility designee will ensure that the facility meets applicable Occupational Safety & Health Act (OSHA) and other requirements that appropriate industrial safety measures are observed, and that applicable personal protective equipment is provided for all personnel involved. The facility designee will ensure that facility personnel use the equipment provided and that the test operation does not present a hazard to the facility. The project designee will ensure that project personnel use the equipment provided and that the test operation does not present a hazard to the space hardware, equipment, or personnel.

#### 1.11 TESTING OF SPARE HARDWARE

A supply of selected spares is often maintained in case of the failure of flight hardware. As a minimum, spares must undergo a verification program equal to that required for follow-on hardware. Therefore, special consideration must be given to spares as follows:

- a. Extent of Testing - The extent and type of testing should be determined as part of the flight hardware test program. A spare unit may be used for qualification of the hardware by subjecting it to protoflight testing, and testing the flight hardware to acceptance levels.
- b. Spares From Failed Elements - If a flight element is replaced for reasons of failure and is then repaired and re-designated as a spare, appropriate retesting should be conducted.
- c. Caution on the Use of Spares - When the need for a spare arises, immediate analysis and review of the failed hardware must be made. If failure occurs in a hardware item of which there are others of identical design, the fault may be generic and may affect all hardware of that design.
- d. "One-Shot" Items - Some items may be degraded or expended during the integration and test period and replaced by spares. The spare that is re-designated for flight should meet the required flight quality control standards or auxiliary tests and should be of qualified design. Examples are pyrotechnic devices, yo-yo despin weights, and elements that absorb impact energy by plastic yielding. When the replacement entails procedures that could jeopardize mission success, the replacement procedure should be successfully demonstrated with the hardware in the same configuration that it will be in when final replacement is to be accomplished.

#### 1.12 TEST FACILITIES, CALIBRATION

The facilities and fixtures used in conducting tests must be capable of producing and maintaining the test conditions prescribed with the test specimen installed and operating or not operating, as required. In any major test, facility performance should be verified prior to the test either by a review of its performance during a test that occurred a short time earlier or by conducting a test with a substitute test item. All measurements that require a specified level of accuracy should be taken using equipment that has been properly calibrated, with documentation available, using one of the standards: ANSI/NCSL z540.1, ANSI/NCSL z540.3, or ISO 17025, IAW GPR 8730.1.

1.13 TEST CONDITION TOLERANCES

In the absence of a rationale for other test condition tolerances, the following should be used; the values include measurement uncertainties:

<u>Acoustics</u>	Overall Level:	$\leq 1$ dB	
	1/3 Octave Band Tolerance:	<u>Frequency (Hz)</u>	<u>Tolerance (dB)</u>
		$f \leq 40$	+3, -6
		$40 < F < 3150$	$\pm 3$
	$f \geq 3150$	+3, -6	
	Duration	+10%, -0%	
<u>Antenna Pattern Determination</u>		$\pm 2$ dB	
<u>Electromagnetic Compatibility</u>			
	Voltage Magnitude:	$\pm 5\%$ of the peak value	
	Current Magnitude:	$\pm 5\%$ of the peak value	
	RF Amplitudes:	$\pm 2$ dB	
	Frequency:	$\pm 2\%$	
	Distance:	$\pm 5\%$ of specified distance or $\pm 5$ cm, whichever is greater	
<u>Humidity</u>		$\pm 5\%$ RH	
<u>Loads</u>	Steady-State (Acceleration):	$\pm 5\%$	
	Sine Burst Amplitude:	$\pm 5\%$	
	Static:	$\pm 5\%$	

<u>Magnetic Properties</u>			
	Mapping Distance Measurement:		± 1 cm
	Displacement of assembly center of gravity (cg) from rotation axis:		± 5 cm
	Vertical displacement of single probe centerline from cg of assembly:		± 5 cm
	Mapping turntable angular displacement:		± 3 degrees
	Magnetic Field Strength:		± 1 nT
	Repeatability of magnetic measurements (short term):		± 5% or ± 2 nT, whichever is greater
	Demagnetizing and Magnetizing Field Level:		±5% of nominal
<u>Mass Properties</u>			
	Weight:		± 0.2%
	Center of Gravity:		± 0.15 cm (± 0.06 in.)
	Moments of Inertia:		± 1.5%
<u>Mechanical Shock</u>			
	Response Spectrum:	Frequency (Hz)	Tolerance (dB)
	Simulated	$F_n \leq 3 \text{ kHz}$	± 6
		$F_n \geq 3 \text{ kHz}$	+9/-6
	Shaker	$F_n \leq 3 \text{ kHz}$	± 3
	Overall Spectrum	> 50% of SRS magnitude above nominal test level	
	Time History:		± 10%
<u>Pressure</u>			
	Greater than $1.3 \times 10^4 \text{ Pa}$ (Greater than 100 mm Hg):		± 5%
	$1.3 \times 10^4$ to $1.3 \times 10^2 \text{ Pa}$ (100 mm Hg to 1 mm Hg):		± 10%
	$1.3 \times 10^2$ to $1.3 \times 10^1 \text{ Pa}$ (1 mm Hg to 1 micron):		± 25%
	Less than $1.3 \times 10^1 \text{ Pa}$ (less than 1 micron):		± 80%

<u>Temperature</u>			$\pm 2^{\circ}\text{C}$
<u>Vibration</u>	Sinusoidal:	Amplitude	$\pm 10\%$
		Frequency	$\pm 2\%$
	Random:	RMS level	$\pm 10\%$
		Accel. Spectral Density	$\pm 3\text{ dB}$
		Duration	+10%/-0%

#### 1.14 TEST MEASUREMENT CONSIDERATIONS

From the moment a test article is excited or illuminated by an environmental source until the article is returned to an ambient condition, measurements should be collected over time at sufficient temporal resolution to capture any relevant frequency- or time-dependent effects and to eliminate, in the cases of an anomaly or test failure, the possibility that the incident was caused by overtest due to an error in process or in the test equipment itself.

## **SECTION 2**

### **VERIFICATION PROGRAM**

## **SECTION 2.1**

### **SYSTEM PERFORMANCE VERIFICATION**

## 2.1 SYSTEM PERFORMANCE VERIFICATION

This section applies to all payloads (spacecraft), subsystems (including instruments), and components. The basic provisions apply to all flight hardware, and associated software, that will be launched by expendable launch vehicles (ELVs).

The GEVS, as its name implies, provides basic guidelines for an environmental verification program. This represents only a portion of the overall system verification and must be integrated into the total system program which verifies that the system will meet the mission requirements. A system performance verification program documenting the overall verification plan, implementation, and results is required which will provide traceability from mission specification requirements to launch and initial on-orbit capability. This will also provide the baseline for tracking on-orbit performance versus pre-launch capability.

### 2.1.1 Documentation Requirements

The following documents should be generated and approved in accordance with the Project Development Schedule.

#### 2.1.1.1 System Performance Verification Plan

A system performance verification plan should be prepared defining the tasks and methods required to determine the ability of the system (or instrument) to meet each program-level performance requirement (structural, thermal, optical, electrical, guidance/control, RF/telemetry, science, mission operational, etc.) and to measure specification compliance. Limitations in the ability to verify any performance requirement should be addressed, including the addition of supplemental tests and/or analyses that will be performed and a risk assessment of the inability to verify the requirement.

The plan should address how compliance with each specification requirement will be verified. If verification relies on the results of measurements and/or analyses performed at lower (or other) levels of assembly, this dependence should be described.

For each analysis activity, the plan should include objectives, a description of the mathematical model, assumptions on which the models will be based, required output, criteria for assessing the acceptability of the results, the interaction with related test activity, if any, and requirements for reports. Analysis results must take into account tolerance build-ups in the parameters being used.

#### 2.1.1.1.1 Environmental Verification Plan

An environmental verification plan should be prepared, either as part of the System Verification Plan or as a separate document, that prescribes the tests and analyses that will collectively demonstrate that the hardware and software comply with the environmental verification requirements.

The environmental verification plan provides the overall approach to accomplishing the environmental verification program. For each test, the verification plan should include the level of assembly, the configuration of the item, objectives, facilities, instrumentation, safety considerations, test article limitations and constraints,

contamination control, test phases and profiles, necessary functional operations, personnel responsibilities, and requirement for procedures and reports. It should also define a rationale for retest determination that does not invalidate previous verification activities. When appropriate, the interaction of the test and analysis activity should be described.

Limitations in the environmental verification program which preclude the verification by test of any system requirement should be documented and if any of these limitations lead to deviations from the GOLD Rules, waivers as appropriate should be submitted. Examples of limitations in the ability to demonstrate requirements include:

- Inability to deploy hardware in a 1-g environment.
- Facility limitations which do not allow testing at system level of assembly.
- Inability to perform certain tests because of contamination control requirements.
- Inability to perform powered-on testing because of voltage breakdown concerns.

Alternative tests and analyses should be evaluated and implemented as appropriate, and an assessment of program risk should be included in the System Performance Verification Plan.

#### 2.1.1.2 System Performance Verification Matrix

A System Performance Verification Matrix should be prepared, and maintained, to show each specification requirement, the reference source (to the specific paragraph or line item), the method of compliance, applicable procedure references, results, report reference numbers, etc. This matrix should be included in the system review data packages showing the current verification status as applicable

##### 2.1.1.2.1 Environmental Test Matrix

As an adjunct to the environmental verification plan, an environmental test matrix should be prepared that summarizes all tests that will be performed on each component, each subsystem, and the payload. The purpose is to provide a ready reference to the contents of the test program in order to prevent the deletion of a portion thereof without an alternative means of accomplishing the objectives; it has the additional purpose of ensuring that all flight hardware has been subjected to environmental exposures that are sufficient to demonstrate acceptable workmanship. In addition, the matrix General Environmental Verification Standard provide traceability of the qualification heritage of hardware. All flight hardware, spares, and prototypes (when appropriate) should be included in the matrix. Details of each test should be provided (e.g., number of thermal cycles, temperature extremes, vibration levels). It should also relate the design environments to the test environments and to the anticipated mission environments. The matrix should be prepared in conjunction with the initial environmental verification plan and should be updated as changes occur.

A sample test matrix is given in Figure 2.1-1. The electrical performance tests that are required to be performed before, during, and following the environmental verification test program are not shown in this sample matrix. Other performance tests,

Check the GSFC Technical Standards Program website at <http://standards.gsfc.nasa.gov> or contact the Executive Secretary for the GSFC Technical Standards Program to verify that this is the correct version prior to use.

measurements, demonstrations, alignments, etc. (electrical, mechanical, optical, etc.), that must be performed to verify hardware/software requirements are also not included in this Environmental Test Matrix. However they should be included in the System Performance Verification Plan.

The test matrix does not have to conform to this format; any format that clearly displays the pertinent information is acceptable.

A complementary matrix should be kept showing the tests that have been performed on each component, subsystem, or payload (or applicable level of assembly). This should include tests performed on prototypes or engineering units used in the qualification program, and should indicate test results (pass/fail or malfunctions).

#### 2.1.1.3 Environmental Verification Specification

An environmental verification specification should be prepared that defines the specific environmental parameters that each hardware element is subjected to either by test or analysis in order to demonstrate its ability to meet the mission performance requirements. Such things as payload peculiarities and interaction with the launch vehicle should be taken into account.

#### 2.1.1.4 Performance Verification Procedures

For each verification test activity conducted at the component, subsystem, and payload levels (or other appropriate levels) of assembly, a verification procedure should be prepared that describes the configuration of the test article, how each test activity contained in the verification plan and specification will be implemented.

Test procedures should contain details such as instrumentation monitoring, facility control sequences, test article functions, test parameters, pass/fail criteria, quality control checkpoints, data collection and reporting requirements. The procedures also should address safety and contamination control provisions.

#### 2.1.1.5 Verification Reports

After each component, subsystem, payload, etc., verification activity has been completed; a report should be submitted. For each environmental test activity, the report should contain, as a minimum, the information in the sample test report contained in Figure 2.1-2a and 2.1-2b. For each analysis activity, the report should describe the degree to which the objectives were accomplished, how well the mathematical model was validated by related test data, and other such significant results. In addition, as-run verification procedures and all test and analysis data should be retained for review.

#### 2.1.1.6 System Performance Verification Report

At the conclusion of the verification program, a final System Performance Verification Report should be delivered comparing the hardware/software specifications with the final verified values (whether measured or computed). It is recommended that this report be subdivided by subsystem/instrument.

The System Performance Verification Report should be maintained "real-time" throughout the program summarizing the successful completion of verification

activities, and showing that the applicable system performance specifications have been acceptably complied with prior to integration of hardware/software into the next higher level of assembly.

The initial report should be provided for the PDR. Current versions should then be provided for review at subsequent major systems reviews.

The final pre-launch System Verification Report should be available for approval for the FRR (Flight Readiness Review).

Following initial on-orbit checkout, the System Verification Report should be completed, and delivered in accordance with the contract schedule.

#### 2.1.1.7 Instrument Verification Documentation

The documentation requirements of sections 2.1.1.1 through 2.1.1.6 also apply to instruments. Following integration of the instruments onto the spacecraft, the spacecraft System Verification Report will include the instrument information.



VERIFICATION TEST REPORT		Page ____ of ____
PROJECT _____		
TEST ITEM _____		
MANUFACTURER _____		
SERIAL NUMBER _____		
<p style="text-align: center; margin: 0;">LEVEL OF ASSEMBLY</p> <input type="checkbox"/> SUBASSEMBLY or ASSEMBLY <input type="checkbox"/> UNIT/COMPONENT <input type="checkbox"/> SECTION <input type="checkbox"/> SUBSYSTEM/INSTRUMENT <input type="checkbox"/> MODULE <input type="checkbox"/> SPACECRAFT/PAYLOAD	<p style="text-align: center; margin: 0;">HARDWARE</p> <input type="checkbox"/> ENGINEERING MODEL <input type="checkbox"/> PROTOTYPE <input type="checkbox"/> PROTOFLIGHT <input type="checkbox"/> FLIGHT <input type="checkbox"/> SPARE	<p style="text-align: center; margin: 0;">TEST</p> <input type="checkbox"/> INITIAL TEST STARTING DATE OF INITIAL TEST _____ <input type="checkbox"/> RETEST <input type="checkbox"/> PARTIAL <input type="checkbox"/> FULL
<p style="text-align: center; margin: 0;">STRUCTURAL - MECHANICAL</p> <input type="checkbox"/> STRUCTURAL LOADS <input type="checkbox"/> STATIC <input type="checkbox"/> ACCEL. <input type="checkbox"/> SINE BURST <input type="checkbox"/> VIBRATION <input type="checkbox"/> RANDOM <input type="checkbox"/> SINE <input type="checkbox"/> ACOUSTICS <input type="checkbox"/> MECHANICAL SHOCK <input type="checkbox"/> ACTUATION <input type="checkbox"/> SIMULATED <input type="checkbox"/> MECHANICAL FUNCTION <input type="checkbox"/> MODAL SURVEY <input type="checkbox"/> PRESSURE PROFILE <input type="checkbox"/> MASS PROPERTIES <input type="checkbox"/> OTHER (explain)	<p style="text-align: center; margin: 0;">ELECTROMAGNETIC COMPATIBILITY</p> <input type="checkbox"/> CONDUCTED EMISSIONS <input type="checkbox"/> RADIATED EMISSION <input type="checkbox"/> CONDUCTED SUSCEPTIBILITY <input type="checkbox"/> RADIATED SUSCEPTIBILITY <input type="checkbox"/> MAGNETIC PROPERTIES	<p style="text-align: center; margin: 0;">THERMAL</p> <input type="checkbox"/> THERMAL-VACUUM (no. of cycles ____ ) <input type="checkbox"/> THERMAL CYCLING (no. of cycles ____ ) <input type="checkbox"/> THERMAL BALANCE <input type="checkbox"/> TEMPERATURE-HUMIDITY <input type="checkbox"/> LEAKAGE <input type="checkbox"/> OTHER (explain)
	<p style="text-align: center; margin: 0;">ELECTRICAL PERFORMANCE</p> <input type="checkbox"/> LPT <input type="checkbox"/> CPT <input type="checkbox"/> END-TO-END <input type="checkbox"/> COMPATIBILITY TEST <input type="checkbox"/> MISSION SIMULATIONS	<p style="text-align: center; margin: 0;">OPTICAL</p> <input type="checkbox"/> EXPLAIN
VERIFICATION PROCEDURE NO.: _____ REV. ____ DATE _____ APPLICABLE VERIFICATION PLAN: _____ FACILITY DESCRIPTION: _____ LOCATION: _____ TEST LOG REFERENCE: _____ COMMENTS: _____		
SIGNATURES COGNIZANT ENGINEER FOR TEST ITEM: _____ DATE: _____ QUALITY ASSURANCE REPRESENTATIVE: _____ DATE: _____ (if required)		

Figure 2.1-2a - Verification Test Report

Check the GSFC Technical Standards Program website at <http://standards.gsfc.nasa.gov> or contact the Executive Secretary for the GSFC Technical Standards Program to verify that this is the correct version prior to use.



## **SECTION 2.2**

### **ENVIRONMENTAL VERIFICATION**

## 2.2 APPLICABILITY

Sections 2.3 through 2.9 give the basic environmental verification program for verifying payloads, subsystems, and components as follows:

- 2.3 Electrical Function & Performance
- 2.4 Structural and Mechanical
- 2.5 EMC
- 2.6 Thermal
- 2.7 Cryogenics and Fluids
- 2.8 Contamination Control
- 2.9 End-to-End Testing (payloads/spacecraft)

### Appendix B GEVS Companion Guide For CubeSats

The verification program applies to payloads and spacecraft that will be launched by expendable launch vehicles (ELVs). For the purposes of this document, a spacecraft is considered a payload, and an instrument is considered to be a subsystem when determining the environmental verification requirements.

The basic provisions are written assuming protoflight hardware. They are, in general, also applicable to prototype hardware. Acceptance requirements are also given for the flight acceptance of previously qualified hardware. This applies to follow-on hardware (multiple copies of the same item) developed for the program, or hardware (from another program) qualified by similarity.

### 2.2.1 Test Sequence and Level of Assembly

The verification activities herein are grouped by discipline; they are not in a recommended sequence of performance. No specific environmental test sequence is required, but the test program should be arranged in a way to best disclose problems and failures associated with the characteristics of the hardware and the mission objectives.

In cases where the magnetic properties of the hardware need to be controlled, the dc magnetics testing should be performed after vibration testing. This provides an opportunity to correct for any magnetization of the flight hardware caused by fields associated with the vibration test equipment.

Table 2.2-1 provides a hierarchy of levels of assembly for the flight hardware, with examples. These level designators are based on those used in the Space Systems Engineering Database developed by The Aerospace Corporation for the Air Force, and agreed to by NASA Headquarters, GSFC, and JPL. The GEVS environmental test requirements generally start at the "unit" level and end at the "system segment" level. However, screening and life-tests often occur at lower levels, and overall system verification continues beyond the "system segment" level.

### 2.2.2 Verification Program Tailoring

The environmental test requirements are written assuming a low-risk program. The environmental program should be tailored to reflect the hardware classification, mission objectives, hardware characteristics such as physical size and complexity, and the level of risk accepted by the project. For example, the "failure-free-performance" requirement may be varied, with GSFC approval, from the baseline to reflect mission duration and risk acceptance.

This document also assumes that the payload/spacecraft is of modular design and can be tested at the unit/component, subsystem/instrument, and system/spacecraft levels of assembly. Often this is not the case. The project must develop a verification program that satisfies the intent of the required verification program while taking into consideration the specific characteristics of the mission and the hardware. For example:

- A spacecraft subsystem, or instrument, may be a functional subdivision of the spacecraft, but it may be distributed throughout the spacecraft rather than being a physical entity. In this case, the environmental tests, and associated functional tests, must be performed at physical levels of assembly (component, section, module, system or instrument [refer to Appendix A - hardware level of assembly]) that are appropriate for the specific hardware. Performance tests and calibrations may still be performed on the functional subsystem or instrument.
- The physical size of the system may necessitate testing at other levels of assembly. Facility limitations may not allow certain environmental tests to be performed at the system level. In this case, testing should be performed at the highest practicable level. Also, for very large systems or subsystems/instruments, tests at additional levels of assembly may be added in order to adequately verify the hardware design, workmanship and/or performance.
- For small payloads, the subsystem level environmental tests may be skipped in favor of testing at the component and system/spacecraft levels. Similarly, for very small instruments the GSFC project may elect to not test all components in favor of testing at the instrument level. These decisions must be made carefully, especially regarding bypassing lower level testing for instruments, because of the increased risk to the program (schedule, cost, etc.) of finding problems late in the planned schedule.
- In some cases, because of the hardware configuration it may be reasonable to test more than one component at a time. The components may be stacked in their flight configuration, and may therefore be tested as a "section". Part of the decision process must consider the physical size and mass of the hardware. The test configuration must allow for adequate dynamic or thermal stress inputs to the hardware to uncover design errors and workmanship flaws.
- Some test requirements stated as subsystem/instrument requirements may be satisfied at a higher level of assembly if approved by the GSFC project. For example, externally induced mechanical shock test requirements may be satisfied at the system level by firing the environment-producing pyro. A simulation of this environment is difficult, especially for large subsystems or instruments.
- Aspects of the design and/or mission may negate certain test conditions to be imposed. For example, if the on-orbit temperature variations are small, less than 5°C, then consideration should be given to waiving the thermal-vacuum cycling at the system, or instrument, level of assembly in favor of increasing the hot and cold dwell times.

The same process must be applied when developing the test plan for an instrument. While testing is required at the instrument component and all-up instrument levels of assembly, additional test levels may be called for because of hardware complexity or physical size.

Table 2.2-1  
Flight System Hardware  
Levels of Assembly

LEVEL OF ASSEMBLY	EXAMPLES
Space System	NASA Spacecraft
Project or Program	TDRS      TIROS      GOES
Operating System	Operating Space System
Integrated Systems	Integrated Flight System (Spacecraft + Upperstage + Launch Vehicle)
System Segment (Satellite, Payload, Spacecraft, Laboratory, Observatory, Space Vehicle, etc.)	(Spacecraft Bus + Science Payload)      Launch Vehicle      IUS
Module	Spacecraft Bus      Science Payload      Payload Fairing
Subsystem	Instrument/Experiment, Structure, Attitude Control, C & DH, Thermal Control, Electrical Power, TT & C, Propulsion
Section (group of units/components not a subsystem)	Electronic Tray or Palette, Stacked Units/Components Electronic Boxes Mounted on Panel, Solar Array Sections
Unit (Component)	Electronic Box, Gyro Package, Motor, Actuator, Battery, Receiver, Transmitter, Antenna, Solar Panel, Valve Regulator
Subassembly (combines assembly and subassembly)	Assembly (Power Amplifier, Gyroscope) Subassembly (Wire Harness, Loaded Printed Circuit Card)
Part	Resistor, Capacitor, IC, Switch, Connector Bolt, Screw, Gasket, Bracket, Valve Stem

### 2.2.3 Qualification of Hardware by Similarity

There are cases in which hardware qualified for one flight program is to be built and used on another program. Hardware that has been previously qualified may be considered qualified for use on a new program by showing that the hardware is sufficiently similar to the original hardware and that the previous qualification program has adequately enveloped the new mission environments. The details for performing this comparison should be defined by the project but as a minimum the following areas should be reviewed and documented:

- (1) Design and test requirements must be shown to envelope the original requirements. This should include a review of the test configuration and of all waivers and deviations that may have occurred during testing of the original hardware.
- (2) Manufacturing information should be reviewed to determine if changes have been made that would invalidate the previous hardware qualification. This review should cover

Check the GSFC Technical Standards Program website at <http://standards.gsfc.nasa.gov> or contact the Executive Secretary for the GSFC Technical Standards Program to verify that this is the correct version prior to use.

parts, materials, packaging techniques as well as changes to the assembly process or procedures.

- (3) Test experience with the previous flight build should be reviewed to verify that no significant modifications were made to the hardware during testing to successfully complete the test program. Any significant change to the heritage hardware should be identified and shown to be implemented on the current flight hardware.

If the review of the above criteria shows that the hardware is of sufficiently similar design as the first build and that the previous test requirements envelope any new environmental requirements, then the hardware can be treated as qualified and need only to be subjected to acceptance level test requirements. The review of the hardware for similarity must be documented and included as part of the verification package.

#### 2.2.4 Test Factors/Durations

Test factors for prototype, protoflight, and acceptance are given in Table 2.2-2. While the acceptance test margin is provided, the test may or may not be required for a specific mission.

#### 2.2.5 Structural Analysis/Design Factors of Safety

Structural and mechanical verification testing should be supported by structural analysis to provide confidence that the hardware will not experience failure or detrimental permanent deformation under test or launch conditions. The factors of safety applied to limit loads in order to calculate structural margins are shown in Table 2.2-3. These factors of safety have been selected to be consistent with the test factors shown in Table 2.2-2. The yield factor of safety ensures that a prototype or protoflight test can be conducted with low risk of the hardware experiencing detrimental yielding. The ultimate factor of safety provides adequate separation between yield and ultimate failure modes and ensures that the hardware will not experience an ultimate failure under expected loading conditions.

In the case of thermally induced loads or stresses, the factors of safety shown in Table 2.2-3 for the static loading condition are to be used for calculating strength margins. If the absolute value of the temperature differential between the stressed and un-stressed condition for the hardware using flight acceptance temperatures is  $\geq 20^{\circ}\text{C}$ , then the static factors of safety from Table 2.2-3 should be applied to the loads/stresses induced by acceptance temperatures. Flight acceptance temperatures are defined as the maximum predicted flight temperature plus acceptance margin which is typically  $5^{\circ}$  for thermal vacuum or  $20^{\circ}$  for thermal cycling at ambient pressure as defined in Table 2.2-2. Survival temperatures are treated as flight acceptance temperatures for assessing strength margins as they do not include qualification margin. If the absolute value of the temperature differential between the stressed and un-stressed condition using flight acceptance temperatures is  $< 20^{\circ}\text{C}$ , then the static factors of safety from Table 2.2-3 can be applied to the loads/stresses induced by qualification temperatures for the hardware. Both hot and cold conditions should be evaluated and the factors of safety should be applied to the appropriate test temperature (acceptance or qualification). Thermally induced loads should be combined with mechanical loading due to launch loads, gravity, or external loads due to enforced deflection if these mechanical loads occur at the same time.

Table 2.2-2  
Test Factors/Durations

Test	Prototype Qualification	Protoflight Qualification	Acceptance
Structural Loads <sup>1</sup> Level  Duration Centrifuge/Static Load <sup>4</sup> Sine Burst	1.25 x Limit Load  1 minute 5 cycles @ full level per axis	1.25 x Limit Load  30 seconds 5 cycles @ full level per axis	1.0 x Limit Load  30 seconds 5 cycles @ full level per axis
Acoustics Level <sup>2</sup> Duration	Limit Level + 3dB 2 minutes	Limit Level + 3dB 1 minute	Limit Level 1 minute
Random Vibration Level <sup>2</sup> Duration	Limit Level + 3dB 2 minutes/axis	Limit Level + 3dB 1 minute/axis	Limit Level 1 minute/axis
Sine Vibration <sup>3</sup> Level Sweep Rate	1.25 x Limit Level 2 oct/min	1.25 x Limit Level 4 oct/min	Limit Level 4 oct/min
Mechanical Shock Actual Device Simulated	2 actuations 1.4 x Limit Level 2 x Each Axis	2 actuations 1.4 x Limit Level 1 x Each Axis	1 actuations Limit Level 1 x Each Axis
Thermal-Vacuum	Max./min. predict. ± 10°C	Max./min. predict. ± 10°C	Max./min. predict. ± 5°C
EMC & Magnetics	As Specified for Mission	Same	Same

- 1 - If qualified by analysis only, positive margins must be shown for factors of safety of 2.0 on yield and 2.6 on ultimate. Beryllium and composite materials cannot be qualified by analysis alone.

Note: Test levels for weldments, beryllium, bonded and composite structure, including metal matrix, are 1.25 x Limit Level for both qualification and acceptance testing.

- 2 - As a minimum, the test level shall be equal to or greater than the workmanship level.
- 3 - The sweep direction should be evaluated and chosen to minimize the risk of damage to the hardware. If a sine sweep is used to satisfy the loads or other requirements, rather than to simulate an oscillatory mission environment, a faster sweep rate may be considered, e.g., 6-8 oct/min to reduce the potential for over stress.
- 4 - Shorter durations may be used in static testing if necessary to protect the hardware from damage due to facility limitations. If a shorter duration is used then the dwell time at load shall be sufficient to demonstrate that the target loading condition has been achieved within the specified tolerances, all test measurements have been recorded, and the structure is stable under the applied loading condition.

Table 2.2-3  
Flight Hardware Design/Analysis Factors of Safety Applied to Limit Loads <sup>1,2</sup>

Type	Static	Sine	Random/Acoustic <sup>4,5</sup>
Metallic Yield	1.25 <sup>3</sup>	1.25	1.6
Metallic Ultimate	1.4 <sup>3</sup>	1.4	1.8
Stability Ultimate	1.4	1.4	1.8
Beryllium Yield	1.4	1.4	1.8
Beryllium Ultimate	1.6	1.6	2.0
Composite Ultimate	1.5	1.5	1.9
Bonded Inserts/Joints Ultimate	1.5	1.5	1.9

1 – Factors of safety for pressurized systems to be compliant with AFSPCMAN 91-710 (Range Safety).

2 – Factors of safety for glass and structural glass bonds specified in NASA-STD-5001

3 – If qualified by analysis only, positive margin must be shown for factors of safety of 2.0 on yield and 2.6 on ultimate. See section 2.4.1.1.1

4 – Factors shown should be applied to statistically derived peak response based on RMS level. As a minimum, the peak response shall be calculated as a 3-sigma value.

5 – Factors shown assume that qualification/protoflight testing is performed at acceptance level plus 3dB. If difference between acceptance and qualification levels is less than 3dB, then above factors may be applied to qualification level minus 3dB instead of analyzing to acceptance level.

**SECTION 2.3**  
**ELECTRICAL FUNCTION & PERFORMANCE**

### 2.3 Electrical Function Test Guidelines

The following paragraphs describe the required electrical functional and performance tests that verify the payload's operation before, during, and after environmental testing. These tests along with all other calibrations, functional/performance tests, measurements/demonstrations, alignments (and alignment verifications), end-to-end tests, simulations, etc., that are part of the overall verification program should be described in the System Performance Verification Plan.

#### 2.3.1 Electrical Interface Tests

Before the integration of an assembly, component, or subsystem into the next higher hardware assembly, electrical interface tests should be performed to verify that all interface signals are within acceptable limits of applicable performance specifications.

Prior to mating with other hardware, electrical harnessing should be tested to verify proper characteristics; such as, routing of electrical signals, impedance, isolation, and overall workmanship.

#### 2.3.2 Comprehensive Performance Tests

A comprehensive performance test (CPT) should be conducted on each hardware element after each stage of assembly: component, subsystem and payload. When environmental testing is performed at a given level of assembly, additional comprehensive performance tests should be conducted during the hot and cold extremes of the temperature or thermal-vacuum test for both maximum and minimum input voltage, and at the conclusion of the environmental test sequence, as well as at other times prescribed in the verification plan, specification, and procedures.

The comprehensive performance test should be a detailed demonstration that the hardware and software meet their performance requirements within allowable tolerances. The test should demonstrate operation of all redundant circuitry and satisfactory performance in all operational modes within practical limits of cost, schedule, and environmental simulation capabilities. The initial CPT serves as a technical baseline against which the results of all later CPTs can be readily compared.

At the payload level, the comprehensive performance test demonstrates that, with the application of known stimuli, the payload will produce the expected responses. At lower levels of assembly, the test demonstrates that, when provided with appropriate inputs, internal performance is satisfactory and outputs are within acceptable limits.

#### 2.3.3 Limited Performance Tests

Limited performance tests (LPT) should be performed before, during, and after environmental tests, as appropriate, in order to demonstrate that functional capability has not been degraded by the tests. The limited tests are also used in cases where comprehensive performance testing is not warranted or not practicable. LPTs should be sufficient to demonstrate that the performance of selected hardware and software functions is within acceptable limits. Specific times when LPTs will be performed should be documented in the verification specification.

#### 2.3.4 Performance Operating Time and Failure-Free Performance Testing

One-thousand (1000) hours of operating/power-on time should be accumulated on all flight electronic hardware, and spares prior to launch. For electronics consisting of a prime and redundant, i.e. A and B sides, 1000 hours should be accumulated on each side.

In addition, at the conclusion of the performance verification program, payloads should have demonstrated failure-free performance testing for at least the last 350 hours of operation. The demonstration may be conducted at the subsystem level of assembly when payload integration is accomplished at the launch site and the 350-hour demonstration cannot practicably be accomplished on the integrated payload. Failure-free operation during the thermal-vacuum test exposure is included as part of the demonstration with 100 hours of the trouble-free operation being logged at the hot-dwell temperatures and 100 hours being logged at the cold-dwell temperature. The 350-hour demonstration should include at least 200 hours in vacuum. Major hardware changes during or after the verification program invalidate previous demonstration.

The general intent of the above requirements is to accumulate 1000 hours of operating time on all flight hardware, and to demonstrate trouble-free performance at high-, low-, and nominal temperature. However, it is understood that under certain conditions this goal may not be met. For example hardware change-out just prior to launch may not provide sufficient time to demonstrate these requirements. Also, the retest requirements following component failure during system level thermal vacuum, or other tests, must be evaluated on a case-by-case basis taking into account the criticality of the hardware element and the risk impact on achieving mission goals.

The guideline time requirements should be tailored up or down to reflect hardware classification, and mission duration.

These requirements also apply to instruments and other spacecraft subsystem hardware prior to delivery for integration into the spacecraft. The Failure-free durations should be set dependent on the mission risk level, hardware complexity, and hardware criticality to the mission.

#### 2.3.5 Limited-Life Electrical Elements

A life test program should be considered for electrical elements that have limited lifetimes. The verification plan should address the life test program, identifying the electrical elements that require such testing, describing the test hardware that will be used, and the test methods that will be employed.

## **SECTION 2.4**

### **STRUCTURAL AND MECHANICAL**

## 2.4 STRUCTURAL AND MECHANICAL VERIFICATION REQUIREMENTS

A series of tests and analyses should be conducted to demonstrate that the flight hardware is qualified for the expected mission environments and that the design of the hardware complies with the specified verification requirements such as factors of safety, interface compatibility, structural reliability, workmanship, and associated elements of system safety.

Table 2.4-1 specifies the structural and mechanical verification activities. When the tests and analyses are planned, consideration must be given to the expected environments of structural loads, vibroacoustics, sine vibration, mechanical shock, and pressure profiles induced during all phases of the mission; for example, during launch, insertion into final orbit, preparation for orbital operations, and entry, descent, and landing. Verification must also be accomplished to ensure that the transportation and handling environments are enveloped by the expected mission environments. Mass properties and proper mechanical functioning should also be verified.

Of equal importance with qualifying the hardware for expected mission environments are the testing for workmanship and structural reliability, which are intended to provide a high probability of proper operation during the mission. In some cases, the expected mission environment is rather benign and produces test levels insufficient to expose workmanship defects. The verification test must envelope the expected mission levels, with appropriate margins added for qualification, and impose sufficient stress to detect workmanship faults. Flight load and dynamic environment levels are probabilistic quantities. Selection of probability levels for flight limit level loads/environments to be used for payload design and testing is the responsibility of the payload project manager, but in no event shall the probability levels be less than the minimum levels in Table 2.4-2. Specific structural reliability requirements regarding fracture control for ELV payloads, beryllium structure, composite structure, bonded structural joints, and glass structural elements are given in 2.4.1.4.

The program outlined in Table 2.4-1 assumes that the payload is sufficiently modularized to permit realistic environmental exposures at the subsystem level. When that is not possible, or at the project's discretion, compliance with the subsystem requirements must be accomplished at a higher or lower level of assembly. For example, structural load tests of some components may be necessary if they cannot be properly applied during testing at higher levels of assembly.

Ground handling, transportation and test fixtures needs to be analyzed and tested for proper strength as required by safety, and should be verified for stability for applicable configurations as appropriate.

Projects should consider metrology verification before and after environmental testing and over temperature for all critical alignments.

### 2.4.1 Structural Loads Qualification

Qualification of the payload for the structural loads environment requires a combination of test and analysis. A test-verified finite element model of the payload must be developed and a coupled loads analysis of the payload/launch vehicle performed.

The analytical results define the limit loads for the payload (subsystems and components) and show compatibility with the launch vehicle for all critical phases of the mission.

TABLE 2.4-1  
Structural and Mechanical Verification Test Requirements

Requirement	Payload/ Spacecraft	Subsystem/ Instrument	Unit (Component) Including Instrument Units (Components)
Structural Loads			
Modal Survey	*	T <sup>2</sup>	*
Design Qualification	*	A,T/A <sup>1</sup>	*
Structural Reliability Primary & Secondary Structure	*	(A,T) <sup>1</sup>	*
Vibroacoustics			
Acoustics	T	T <sup>2</sup>	T <sup>2</sup>
Random Vibration	T <sup>2</sup>	T <sup>2</sup>	T
Sine Vibration	T <sup>3</sup> ,T <sup>4</sup>	T <sup>3</sup>	T <sup>3</sup>
Mechanical Shock	T	T <sup>5</sup>	T <sup>5</sup>
Mechanical Function	A,T	A,T	-
Pressure Profile	-	A,T <sup>2</sup>	A
Mass Properties	A/T	A,T <sup>2</sup>	*

\* = May be performed at payload or component level of assembly if appropriate.

A = Analysis required.

T = Test required.

A/T = Analysis and/or test.

A, T/A<sup>1</sup> = Analysis and Test or analysis only if no-test factors of safety given in 2.4.1.1.1 are used.

(A, T)<sup>1</sup> = Combination of fracture analysis and proof tests on selected elements, with special attention given to beryllium, composites, bonded joints and weldments.

T<sup>2</sup> = Test must be performed unless assessment justifies deletion.

T<sup>3</sup> = Test performed to simulate low frequency transient vibration and any sustained periodic mission environment, or to satisfy other requirement such as strength qualification.

T<sup>4</sup> = Test must be performed for ELV payloads, if practicable, to simulate transient and any sustained periodic vibration mission environment.

T<sup>5</sup> = Test required for self-induced shocks, but may be performed at payload level of assembly for externally induced shocks.

TABLE 2.4-2  
Minimum Probability-Level Requirements  
for Flight Limit (maximum expected) Level

Requirement	Minimum Probability Level
	ELV Payloads
Structural Loads	97.72/50 (1),(2)
Vibroacoustics Acoustics Random Vibration	95/50
Sine Vibration	97.72/50 (1)
Mechanical Shock	95/50
Notes:	
(1) When parametric statistical methods are used to determine the limit level, the data should be tested to show a satisfactory fit to the assumed underlying distribution.	
(2) 97.72% probability of not exceeding level, estimated with 50% confidence. Equal to the mean plus two-sigma level for normal distributions.	

A modal survey shall be performed for each payload (at the subsystem/instrument or other appropriate level of assembly) to verify that the analytical model adequately represents the dynamic behavior of the hardware. The test-verified model shall then be used to predict the maximum expected load for each critical loading condition, including handling and transportation, vibroacoustic effects during lift-off, insertion into final orbit, orbital operations, thermal effects during landing, etc., as appropriate for the particular mission. If the payload configuration is different for various phases of the mission, the structural loads qualification program, including the modal survey, must consider the different configurations. The maximum loads resulting from the analysis define the limit loads.

The launch loads environment is made up of a combination of steady-state, low-frequency transient, and higher-frequency vibroacoustic loads. To determine the combined loads for any phase of the launch, the root-sum-square (RSS) of the low- and high-frequency dynamic components are superimposed upon the steady-state component if appropriate.

$$N_i = S_i \pm [(L_i)^2 + (R_i)^2]^{1/2}$$

Where  $N_i$ ,  $S_i$ ,  $L_i$ , and  $R_i$  are the combined load factor, steady-state load factor, low-frequency dynamic load factor, and high-frequency random vibration load factor, respectively, for the  $i$ 'th axis. In some cases, the steady-state and low-frequency dynamic load factors are combined into a low-frequency transient load factor  $A_i$ . In this case, the steady-state value must be separated out before the RSS operation.

When determining the limit loads for ELV launches, consideration must be given to the timing of the loading events; the maximum steady state and dynamic events occur at different times in the launch and may provide too conservative an estimate if combined. Also, the frequency band of the vibroacoustic energy to be combined must be evaluated on a case-by-case basis. Flight events which must be considered for inclusion in the coupled loads analysis for various ELV's are listed in Table 2.4-3. If the verification cycle analysis or payload test-verified model is not available, the latest analytical data should be used in conjunction with a suitable uncertainty factor.

Each subsystem/instrument shall then be qualified by loads testing to 1.25 times the limit loads defined above. The loads test shall be accompanied by stress analysis showing positive margins of safety using the appropriate factors of safety defined in Table 2.2-3. In some cases, qualification by analysis may be allowed (see 2.4.1.3). Special design and test factors of safety are required for beryllium structure (see 2.4.1.3.1).

#### 2.4.1.1 Coupled load analysis

A coupled load analysis, combining the launch vehicle and payload, shall be performed to support the verification of positive stress margins and sufficient clearances during the launch.

##### 2.4.1.1.1 Analysis - Strength Verification

A finite element model shall be developed (and verified by test) that analytically simulates the payload's mass and stiffness characteristics, for the purpose of performing a coupled loads analysis. The model shall be of sufficient detail to make possible an analysis that defines the payload's modal frequencies and displacements below a specified frequency that is dependent on the fidelity of the launch vehicle finite element model. For ELV all significant modes below 70 Hz are sufficient unless higher-frequency modes are required by the launch vehicle manufacturer.

The model is then coupled with the model of the ELV and any upper-stage propulsion system. The combined coupled model is used to conduct a coupled loads analysis that evaluates all potentially critical loading conditions. Forcing functions used in the coupled loads analysis shall be defined at the flight limit level consistent with the minimum probability levels of Table 2.4-2. The results of the coupled loads analysis shall be reviewed to determine the worst-case loads. These constitute the set of limit loads that are used to evaluate member loads and stresses.

For ELV payloads, the coupled loads analysis shall consider all flight events required by the ELV provider. None of the flight events shall be deleted from the coupled loads analysis unless it is shown by base drive analysis of the cantilevered spacecraft and adapter that there are no significant spacecraft vibration modes in frequency bands of significant launch vehicle forcing functions and coupled-mode responses. For example, it should be confirmed that there are no spacecraft structural components or subsystems (upper platforms, antenna supports, scientific instruments, etc.) which can experience high dynamic responses during flight events such as lift-off or sustained, pogo-like oscillations before deleting these events. For the evaluation of flight events to include in the coupled loads analysis, an appropriate

tolerance should be applied to all potentially significant spacecraft modal frequencies unless verified by modal survey testing.

Normally, the design and verification of payloads should not be burdened by transportation and handling environments that exceed stresses expected during launch, orbit, or return. Rather, shipping containers should be designed to prevent the imposition of such stresses. To verify this, a documented analysis shall be prepared on shipping and handling equipment to define the loads transmitted to flight hardware. When transportation and handling loads are not enveloped by the maximum expected flight loads, the transportation and handling loads should be included in the set of limit loads.

For those hardware items that will later be subjected to a strength qualification test, a stress analysis shall be performed to provide confidence that the risk of failing the strength test is small and to demonstrate compliance with the launch vehicle interface verification and safety requirements. The analysis shall show positive margins using the appropriate factors of safety defined in Table 2.2-3.

For payloads, or payload elements, whose strength is qualified by analysis, the objective of the stress analysis is to demonstrate with a high degree of confidence that there is essentially no chance of failure during flight. For all elements that are to be qualified by analysis, positive strength margins on yield shall be shown to exist at stresses equal to 2.0 times those induced by the limit loads, and positive margins on ultimate shall be shown to exist at stresses equal to 2.6 times those induced by the limit loads. For additional qualification by analysis requirements, see 2.4.1.3. When qualification by analysis is used, the upper frequency of the modal survey may have to be increased. Locations with small margins should be verified by metrology.

#### 2.4.1.1.2 Analysis - Clearance Verification

Analysis shall be conducted for all ELV payloads to verify adequate dynamic clearances between the payload and launch vehicle and between members within the payload for all significant ground test and flight conditions.

- a. During Powered Flight - The coupled loads analysis shall be used to verify adequate clearances during flight within ELV payload fairing. One part of the coupled loads analysis output transformation matrices shall contain displacement data that will allow calculation of loss of clearance between critical extremities of the payload and adjacent surfaces of ELV. For ELV payloads, the analysis should consider clearances between the payload and ELV payload fairing (and its acoustic blankets if used, including blanket expansion due to venting) and between the payload and ELV attach fitting, as applicable. For the clearance calculations the following factors should be considered:
  1. Worst-case payload and vehicle manufacturing and assembly tolerances as derived from as-built engineering drawings.
  2. Worst-case payload/vehicle integration "stacking" tolerances related to interface mating surface parallelism, perpendicularity and concentricity, plus bolt positional tolerances, ELV payload fairing ovality, etc.
  3. Quasi-static and dynamic flight loads, including coupled steady-state and transient sinusoidal vibration, vibroacoustics and venting loads, as applicable. Typically, either liftoff or the transonic buffet and maximum airloads cause the greatest relative deflections between the vehicle and payload.

- b. During ELV Payload Fairing Separation - A fairing separation analysis based on ground separation test of the fairing, shall be used to verify adequate clearances between the separating fairing sections and payload extremities. Effects of fairing section shell-mode oscillations, fairing rocking, vehicle residual rates, transient coupled-mode oscillations, thrust accelerations, and vehicle control-jet firings shall be considered, as applicable.
- c. During Payload Separation - A payload separation analysis shall be used to verify adequate clearances between the payload and the ELV during separation. The analysis shall include effects of factors such as vehicle residual rates, forces and impulses imparted by the separation system (including lateral impulses due to separation clampbands) and vehicle retro-rocket plumes impinging on the payload, as applicable. The same analysis should be utilized to verify acceptable payload separation velocity and tip-off rates if required

Analysis should also be performed to verify adequate critical dynamic clearances between members within the payload during ground vibration and acoustic testing, and flight. Additionally, a deployment analysis shall be used to verify adequate clearances during payload appendage deployment. Refer to 2.4.5.2 regarding mechanical function clearances.

For all of the above clearance analyses and conditions, adequate clearances shall be verified assuming worst-case static clearances due to manufacturing, assembly and vehicle integration tolerances (unless measured on the launch stand), and quasi-static and dynamic deflections due to 1.4 times the applicable flight limit loads or flight-level ground test levels. Depending on the available static clearance, the clearance analysis requirements may be satisfied in many cases by simple worst-case estimates and/or similarity. Locations with small margins should be verified with metrology.

#### 2.4.1.2 Modal Survey

A modal survey test will be required for payloads and subsystems, including instruments, that have modes with significant modal mass within the frequency range of the launch vehicle coupled loads analysis. The frequency range covered by coupled loads analysis is dependent on the specific launch vehicle. The determination that a modal test is required will be made on a case-by-case basis and will be specified in the design and test requirements. Modal analysis of the hardware with appropriate boundary conditions may be used to determine the need for performing a modal survey. If the determination is made that a modal survey test is not required because the hardware does not have significant modes in the coupled loads range, then the fundamental frequency of the hardware shall be verified during vibration testing. A low-level sine survey is generally an appropriate method for determining fundamental frequency.

Modal tests are generally performed at the subsystem/instrument level of assembly, but may be required at other levels of assembly such as the payload or component level depending on project requirements.

In general, the support of the hardware during the test should duplicate the boundary conditions expected during launch. When that is not feasible, other boundary conditions are employed and the frequency limits of the test are adjusted accordingly. The effects of interface flexibilities should be considered when other than normal boundary conditions are used.

The results of the modal survey are required to identify any inaccuracies in the mathematical model used in the payload analysis program so that modifications can be made if needed. Such an experimental verification is required because a degree of uncertainty exists in

unverified models owing to assumptions inherent in the modeling process. These lead to uncertainties in the results of the flight dynamic loads analysis, thereby reducing confidence in the accuracy of the set of limit loads derived therefrom.

If a modal survey test is required, all significant modes up to the required frequency must be determined both in terms of frequency and mode shape. A mode is considered significant if it has modal effect mass that is equal to or greater than 5% of the total mass of the hardware at the level of assembly for which the modal survey is being considered. Modes that drive high responses of critical components from a coupled loads analysis should also be considered as target modes for a modal survey. Cross-orthogonality checks of the test and analytical mode shapes, with respect to the analytical mass matrix, shall be performed with the goal of obtaining at least 0.9 on the diagonal and no greater than 0.1 off-diagonal. Frequencies between the corresponding test and analytical modes shall match within 5%. Any test method that is capable of meeting the test objectives with the necessary accuracy may be used to perform the modal survey.

When a satisfactory modal survey has been conducted on a representative structural model, a modal survey of the protoflight unit may be unnecessary. A representative structural model is defined as one that duplicates the structure as to materials, configuration, fabrication, and assembly methods and that satisfactorily simulates other items that mount on the structure as to location, method of attachment, weight, mass properties, and dynamic characteristics.

#### 2.4.1.3 Design Strength Qualification

The preferred method of verifying adequate strength is to apply a set of loads that will generate forces in the hardware that are equal to 1.25 times limit loads. The strength qualification test must be shown to produce forces equal to 1.25 times limit at structural interfaces as well as in structural elements which have been shown to have the lowest margins for all identified failure modes of the hardware. As many test conditions as necessary should be applied to achieve the appropriate loads for qualification. Structural qualification testing should be performed at the lowest level of assembly as possible to reduce overtest and to limit the risk of damage to other components/subsystems should structural failure occur. After structural testing, the hardware must be capable of meeting its performance criteria (see 2.4.1.3.1 for special requirements for beryllium structure). No detrimental permanent deformation shall be allowed to occur as a result of applying the loads, and all applicable alignment requirements must be met following the test.

The requirement to achieve a test factor of 1.25 times limit load for qualification only applies to mechanically induced loading from launch and on-orbit operations. It is usually not possible to achieve a test factor of 1.25 on thermal loads by exposing the hardware to qualification temperatures. In the case of thermally induced loads, qualification or proof testing shall be performed to qualification temperatures only, without the need for additional test margin. In the case where the qualification or proof test is intended to represent a combined loading condition of thermal and mechanical loading, only the mechanical portion of the load shall be increased by a 1.25 test factor. Analysis for thermally induced loads shall demonstrate positive margins using the standard factors of safety as defined in Table 2.2-3.

The strength qualification test must be accompanied by a stress analysis that demonstrates positive margins using the appropriate factors of safety defined in Table 2.2-3. See 2.4.1.3.1 for special requirements for beryllium structure.

In addition, the analysis shall show that at stresses equal to the limit load, the maximum allowable loads at the launch vehicle interface points are not exceeded and that no excessive deformations occur that might constitute a hazard to the mission. This analysis should be

performed prior to the start of the strength qualification tests to provide minimal risk of damage to hardware. When satisfactory qualification tests have been conducted on a representative structural model, the strength qualification testing of the protoflight unit may not be necessary.

- a. Selection of Test Method - The qualification load conditions may be applied by acceleration testing, static load testing, or vibration testing (either transient, fixed frequency or swept sinusoidal excitation). Random vibration is generally not acceptable for loads testing.

The following questions should be considered when the method to be employed for verification tests is selected:

- (1) Which method most closely approximates the flight-imposed load distribution?
- (2) Which can be applied with the greatest accuracy?
- (3) Which best provides information for design verification and for predicting design capability for future payload or launch vehicle modifications?
- (4) Which poses the least risk to the hardware in terms of handling and test equipment?
- (5) Which best stays within cost, time, and facility limitations?

- b. Test Setup - The subsystem/instrument shall be attached to the test equipment by a fixture whose mechanical interface simulates the mounting of the subsystem/instrument into the payload with particular attention paid to duplicating the actual mounting contact area. In mating the subsystem to the fixture, a flight-type mounting (including vibration isolators or kinematic mounts if part of the design) and fasteners shall be used.

Components that are normally sealed shall be pressurized during the test to their prelaunch pressure. In cases when significant changes in strength, stiffness, or applied load result from variations in internal and external pressure during the launch phase, a special test shall be considered to cover those effects.

When acceleration testing is performed, the centrifuge shall be large enough so that the applied load at the extreme ends of the test item does not differ by more than 10 percent from that applied to the center of gravity. In addition, when the proper orientation for the applied acceleration vector is computed, ambient gravity effects shall be considered.

- c. Performance - Before and after the strength qualification test, the subsystem/instrument shall be examined and functionally tested to verify compliance with all performance criteria. During the tests, performance shall be monitored in accordance with the verification specification and procedures.

If appropriate development tests are performed to verify accuracy of the stress model, stringent quality control procedures are invoked to ensure conformance of the structure (materials, fasteners, processes, etc.) to the design, and the structure has well-defined load paths, then strength qualification may (with payload project concurrence) be accomplished by a stress analysis that demonstrates that the hardware has positive margins on yield at loads equal to 2.0 times the limit load, and positive margin on ultimate at loads equal to 2.6 times the limit load. Factors of safety lower than 2.0 on yield and 2.6 on ultimate will be considered when they can be shown to be warranted. Justification for the lower factors of safety must be

based on the merits of a particular combination of test and analysis and a correlation of the two. Such alternative approaches shall be reviewed and approved on a case-by-case basis. In addition, at stresses equal to the limit load, the analysis shall show that the maximum allowable loads at the launch vehicle interface points are not exceeded and that no excessive deformations occur.

Structural elements fabricated from composite materials, beryllium or structures that have bonded or welded joints shall not be qualified by analysis alone.

#### 2.4.1.3.1 Strength Qualification - Beryllium

All beryllium primary and secondary structural elements shall undergo a strength test to 1.25 times limit load. No detrimental permanent deformation shall be allowed to occur as a result of applying the loads, and applicable alignment requirements must be met following the test. In addition:

- a. When using cross-rolled sheet, the design shall preclude out-of-plane loads and displacements during assembly, testing, or service life.
- b. In order to account for uncertainties in material properties and local stress levels, a design factor of safety of 1.4 on yield and 1.6 on ultimate material strength shall be used.
- c. Stress analysis shall properly account for the lack of ductility of the material by rigorous treatment of applied loads, boundary conditions, assembly stresses, stress concentrations, thermal cycling, and possible material anisotropy. The stress analysis shall take into account worst-case tolerance conditions.
- d. All machined and/or mechanically disturbed surfaces shall be chemically milled to ensure removal of surface damage and residual stresses.
- e. All parts shall undergo penetrant inspection for surface cracks and crack-like flaws per NASA-STD-5009.

#### 2.4.1.4 Structural Reliability (Residual Strength Verification)

Structural reliability requirements are intended to provide a high probability of the structural integrity of all flight hardware. They are generally covered by the selection of materials, process controls, selected analyses (stress, and fracture mechanics/crack growth), and loads/proof tests.

All structural materials contain defects such as inclusions, porosity, and cracks. To ensure that adequate residual strength (strength remaining after the flaws are accounted for) is present for structural reliability at launch, a fracture control program, or a combination of fracture control and specific loads tests shall be performed on all flight hardware as specified below.

The use of materials that are susceptible to brittle fracture or stress-corrosion cracking require development of, and strict adherence to, special procedures to prevent problems. If materials are used for structural applications that are not listed in Table 1 of MSFC-SPEC-3029, a Materials Usage Agreement (MUA) must be negotiated with the project office. Refer to project Materials and Processes Control Requirements for applicable requirements.

#### 2.4.1.4.1 Primary and Secondary Structure:

ELV Payloads - The following requirements regarding beryllium, nonmetallic-composite, and metallic-honeycomb structural elements (both primary and secondary), and bonded structural joints apply to ELV payloads:

- a. Beryllium Primary and Secondary Structure: The requirements of section 2.4.1.3.1, Strength Verification-Beryllium, apply for structural reliability.
- b. Nonmetallic Composite Structural Elements (including metal matrix): It is preferred that all flight structural elements shall be proof tested to 1.25 times limit load (even if previously qualified on valid prototype hardware). However, if this is not feasible then it is acceptable to proof test a representative set of structural elements to 1.25 times the highest limit load for that type of structure. The remainder of the structural elements may then be considered qualified by similarity. In order to use this approach, the allowables used to assess structural margins must be developed based on coupon testing and standard statistical techniques. As a minimum, B-basis allowables shall be used. In addition:
  - (1) A process control plan shall be developed and implemented to ensure uniformity of processing among test coupons, test articles, and flight hardware as required by the project Materials and Processes Control Requirements.
  - (2) A damage control plan shall be implemented to establish procedures and controls to prevent and/or identify nonvisible impact damage which may cause premature failure of composite elements.
- c. Metallic Honeycomb (both facesheets and core) Structural Elements:
  - (1) Appropriate process controls and coupon testing shall be implemented to demonstrate that the honeycomb structure is acceptable for use as payload flight structure as required by the project Materials and Processes Control Requirements.
  - (2) Metallic honeycomb is not considered to be a composite material.
- d. Bonded Structural Joints (either metal-metal or metal-nonmetal):
  - (1) It is preferred that every bonded structural joint in a flight article shall be proof tested (by static loads test) to 1.25 times limit load. For example, proof loads testing shall be performed to demonstrate that inserts will not tear out from honeycomb under protoflight loads. However, in cases where this approach is not feasible, it is acceptable to test a representative sample of the bonded structural joints in the flight article. As a minimum, at least one of each type of bonded joint in the flight article shall be tested to 1.25 times the maximum predicted limit load for that joint type. The remainder of the bonded joints may then be considered to be qualified by similarity. The use of this approach requires that bonded joint allowables be developed based on coupon testing or testing of sample joints and standard statistical techniques. As a minimum, B-basis allowables shall be used.

- (2) A process control plan shall be developed and implemented as required by applicable project Materials and Processes Control Requirements to ensure uniformity of processing among test coupons, test articles, and flight hardware.
  - (3) Composite or metallic honeycomb panels with bonded structural joints (fittings, inserts, doublers, and splices) in composite and metallic honeycomb shall be thermally cycled to the worst case temperature extremes prior to being subjected to structural proof testing. Primary and secondary structure with bonded joints whose strength margins are driven by thermal loading should also be thermally cycled prior to proof testing.
- e. Weldments:
- (1) All flight structure with critical welds shall be proof tested to 1.25 times limit loads. A critical weld is defined as a weld in which a single failure will result in loss of load carrying capability under the applied loading condition.
  - (2) Appropriate NDE inspection shall be performed shall be performed on critical welds before and after proof testing.
- f. Fracture Control Requirements: If the payload is to be placed in orbit by an ELV, fracture control requirements (per NASA-STD-5019) shall apply to the following elements only:
- (1) Pressure vessels, dewars, lines, and fittings (per NHB-8071.1),
  - (2) Castings (unless hot isostatically pressed and the flight article is proof tested to 1.25 times limit load),
  - (3) Weldments,
  - (4) Parts made of materials on Tables II or III of MSFC-SPEC-3029 if under sustained tensile stress. (Note: All structural applications of these materials require that a Materials Usage Agreement (MUA) must be negotiated with the project office; refer to project Materials and Processes Control Requirements,
  - (5) Parts made of materials susceptible to cracking during quenching,
  - (6) Nonredundant, mission-critical preloaded springs loaded to greater than 25 percent of ultimate strength.

All glass elements that are stressed above 10% of their ultimate tensile strength shall also be shown by fracture analysis to satisfy "Safe-life" or "Fail-safe" conditions or be subjected to a proof loads test at 1.0 times limit level.

#### 2.4.1.5 Acceptance Requirements

All of the structural reliability requirements of 2.4.1.4 (as specified for ELV payloads) apply for the acceptance of all flight hardware.

Generally, structural design loads testing is not required for flight structure that has been previously qualified for the current mission as part of a valid prototype or protoflight test. However, the following acceptance/proof loads tests are required unless equivalent load-level testing was performed on the actual flight hardware as part of a protoflight test program:

a. For ELV Payloads

- (1) Beryllium structure (primary and secondary) shall be proof tested to 1.25 times limit load.
- (2) Nonmetallic composites (including metal matrix) structural elements shall be proof tested to 1.25 times limit load.
- (3) Bonded structural joints shall be proof tested (by static loads test) to 1.25 times limit load.
- (4) Critical welds in flight structure shall be proof tested to 1.25 times limit load (See Section 2.4.2.4.1e for the definition of critical welds).

If a follow-on spacecraft receives structural modifications or a new complement of instruments, it must be requalified for the loads environment if analysis so indicates.

2.4.2 Vibroacoustic Qualification

Qualification for the vibroacoustics environment generally requires an acoustics test at the payload level of assembly and random vibration tests on all components, instruments, and on the payload, when appropriate, to better simulate the structure borne inputs. In addition, random vibration tests shall be performed on all subsystems unless an assessment of the expected environment indicates that the subsystem will not be exposed to any significant vibration input. Similarly, an acoustic test shall be performed on subsystems/instruments and components unless an assessment of the hardware indicates that they are not susceptible to the expected acoustic environment or that testing at higher levels of assembly provides sufficient exposure at an acceptable level of risk to the program. Irrespective of the above stated conditions, these additional tests may be required to satisfy delivery requirements.

It is understood that for some payload projects, the vibroacoustic qualification program may have to be modified. For example, for very large payloads it may be impracticable because of test facility limitations to perform testing at the required level of assembly. In that case, testing at the highest practicable level of assembly should be performed, and additional tests and/or analyses added to the verification program if appropriate. Also, the risk to the program associated with the modified test program shall be assessed and documented in the System Verification Plan.

Similarly, for very large components, the random vibration tests may have to be supplemented or replaced by an acoustic test. If the component level tests are not capable of inducing sufficient excitation to internal electric, electronic, and electromechanical devices to provide adequate workmanship verification, it is recommended that an environmental stress screening test program be conducted at lower levels of assembly (subassembly or board level).

For the vibroacoustic environment, limit levels shall be used which are consistent with the minimum probability levels of Table 2.4-2. The protoflight qualification level is defined as the flight limit level plus 3 dB. When random vibration levels are determined, responses to the acoustic inputs plus the effects of vibration transmitted through the structure should be considered.

The random vibration test levels to be used for hardware containing delicate optics, sensors/detectors, etc., may be notched in frequency bands known to be destructive to the hardware with project concurrence. A force-limiting control strategy is recommended. This requires a dual control system which will automatically notch the input so as not to exceed design/expected forces in the area of rigid, shaker mounted resonances while maintaining

acceleration control over the remainder of the frequency band. The control methodology must be approved by the GSFC project. More information on implementing the force-limiting control strategy can be found in Force Limited Vibration Testing NASA Technical Handbook, NASA-HDBK-7004.

As a minimum, the vibroacoustic test levels shall be sufficient to demonstrate acceptable workmanship.

During test, the test item should be in an operational configuration, both electrically and mechanically, representative of its configuration at lift-off.

The vibroacoustic (acoustics plus random vibration) environmental test program should be included in the environmental verification plan and environmental verification specification.

#### 2.4.2.1 Fatigue Life Considerations

The nature of the protoflight test program prevents a demonstration of hardware lifetime because the same hardware is both tested and flown. When hardware reliability considerations demand the demonstration of a specific hardware lifetime, a prototype verification program must be employed, and the test durations must be modified accordingly.

Specifically, the duration of the vibroacoustic exposures shall be extended to account for the life that the flight hardware will experience during its mission. In order to account for the scatter factor associated with the demonstration of fatigue life, the duration of prototype exposures shall be at least four times the intended life of the flight hardware. For ELV payloads, the duration of the exposure shall be based on both the vibroacoustic and sine vibration environments.

If there is the possibility of thermally induced structural fatigue (examples include solar arrays, antennas, etc.), thermal cycle testing shall be performed on prototype hardware. For large solar arrays, a representative smaller qualification panel may be used for test provided that it contains all of the full scale design details (including at least 100 solar cells) susceptible to thermal fatigue. The life test should normally be performed at the worst case (limit level) predicted temperature extremes for a number of thermal cycles corresponding to the required mission life. However, if required by schedule considerations, the test program may be accelerated by increasing the temperature cycle range (and possibly the temperature transition rate) provided that stress analysis shows no unrealistic failure modes are produced by the accelerated testing.

#### 2.4.2.2 Payload Acoustic Test

At the payload level of assembly, protoflight hardware shall be subjected to an acoustic test in a sound pressure field to verify its ability to survive the lift-off acoustic environment and to provide a final workmanship acoustic test. The test specification is dependent on the payload-launch vehicle configuration and must be determined on a case-by-case basis. The minimum overall test level should be at least 138 dB. If the test specification derived from the launch vehicle expected environment, including fill-factor, is less than 138 dB, the test profile should be raised to provide a 138 dB test level. The planned test and specification levels shall be confirmed by the launch vehicle program office.

- a. Facilities and Test Control - The acoustic test shall be conducted in an area large enough to maintain a uniform sound field at all points surrounding the test item. The sound pressure level is controlled at one-third octave band resolution. The preferred method of control is to average four or more microphones with a real-time device that effectively averages the sound pressure level in each filter band. When real-time averaging is not practicable, a survey of the chamber shall be performed to determine the single point that is most suitable for control of the acoustic test.

Regardless of the control method employed, a minimum of four microphones shall be positioned around the test chamber at sufficient distance from all surfaces to avoid absorption or re-radiation effects. One of the microphones should be located above the test item for a free-field test. A distance from any surface of at least 1/4 the wavelength of the lowest frequency of interest is recommended. It is recognized that this cannot be achieved in some facilities, particularly when noise levels are specified to frequencies as low as 25 Hz. In such cases, the microphones shall be located in positions so as to be affected as little as possible by surface effects.

The preferred method of preparing for an acoustic test is to preshape the spectrum of the acoustic field with a dummy test item. If no such item is readily available, it is possible to preshape the spectrum in an empty test area. In that case, however, a low-level test should be performed after the test item has been placed in the test area to permit final adjustments to the shape of the acoustic spectrum.

Acoustic testing may be performed in a reverberant chamber or may be performed as a direct-acoustic field (DAF) test in which the acoustic pressure field is generated by banks of speakers. The preferred method for performing acoustic testing on flight hardware is with a reverberant chamber test. Comparison of data from test articles subjected to both reverberant and current state-of-the art DAF testing showed that the pressure field and measured responses from DAF testing can differ significantly from a reverberant field test even if the control microphones are kept within the test tolerances specified in Section 1.13. Because of the non-uniformity that may exist in the acoustic field generated by DAF testing, care must be taken when performing this type of test to have sufficient instrumentation on the test article to prevent exceeding hardware capability as the test level is increased and have an adequate number of microphones in place during the test to monitor the pressure field generated near critical items. It should also be noted that variability in the acoustic field generated by a DAF test may result in under-testing as well as over-testing in specific frequency bands and all efforts should be made to map the acoustic field relative to acoustically sensitive hardware to ensure that an adequate test can be achieved.

- b. Test Setup - The boundary conditions under which the hardware is supported during test shall duplicate those expected during flight. When that is not feasible, the test item shall be mounted in the test chamber in such a manner as to be isolated from all energy inputs on a soft suspension system (natural frequency less than 20 Hz) and a sufficient distance from chamber surfaces to minimize surface effects. During test, the test item should be in an operational configuration, both electrically and mechanically, representative of its configuration at lift-off.
- c. Performance - Before and after the acoustic exposure, the payload shall be examined and functionally tested. During the test, performance shall be monitored in accordance with the verification specification.

#### 2.4.2.3 Payload Random Vibration Tests

At the payload level of assembly, protoflight hardware shall, when practicable, be subjected to a random vibration test to verify its ability to survive the lift-off environment and also to provide a final workmanship vibration test. For small payloads (<454 kg or 1000 lb), the test is required; for larger payloads the need to perform a random vibration test shall be assessed on a case-by-case basis. Additional qualification tests may be required if expected environments are not enveloped by this test. The acoustic environment at lift-off is usually the primary source of random vibration; however, other sources of random vibration must be considered. The sources include transonic aerodynamic fluctuating pressures and the firing of retro/apogee motors.

- a. Lift-Off Random Vibration - Protoflight hardware shall be subjected to a random vibration test to verify flightworthiness and workmanship. The test level shall represent the qualification level (flight limit level plus 3 dB).

The test is intended for payloads (spacecraft) of low to moderate weight and size. For small payloads, such as Pegasus-launched spacecraft, the test should cover the full 20-2000 Hz frequency range. In such cases, the project should assess and recommend a random vibration test, acoustic test, or both, depending on the payload. For larger ELV payloads, the test is not required unless there is a close-coupled, direct structural load path to the launch vehicle external skin. In that case, both lift-off and transonic random vibration must be considered.

The payload in its launch configuration shall be attached to a vibration fixture by use of a flight-type launch-vehicle adapter and attachment hardware. Vibration shall be applied at the base of the adapter in each of three orthogonal axes, one of which is parallel to the thrust axis. The excitation spectrum as measured by the control accelerometer(s) shall be equalized such that the acceleration spectral density is maintained within  $\pm 3$  dB of the specified level at all frequencies within the test range and the overall RMS level is within  $\pm 10\%$  of the specified level.

Prior to the payload test, a survey of the test fixture/exciter combination shall be performed to evaluate the fixture dynamics, the proposed choice of control accelerometer locations, and the control strategy. If a mechanical test model of the payload is available it should be included in the survey to evaluate the need for limiting.

If a random vibration test is not performed at the payload level of assembly, the feasibility of doing the test at the next lower level of assembly shall be assessed.

- b. Performance - Before and after each vibration test, the payload shall be examined and functionally tested. During the tests, performance shall be monitored in accordance with the verification specification.

#### 2.4.2.4 Subsystem/Instrument Vibroacoustic Tests

If subsystems are expected to be significantly excited by structure-borne random vibration, a random vibration test shall be performed. Specific test levels are determined on a case-by-case basis. The levels shall be equal to the qualification level as predicted at the location where the input will be controlled. Subsystem acoustic tests may also be required if the subsystem is judged to be sensitive to this environment or if it is necessary to meet delivery specifications. A random vibration test is generally required for instruments.

#### 2.4.2.5 Component/Unit Vibroacoustic Tests

As a screen for design and workmanship defects, components/units shall be subjected to a random vibration test along each of three mutually perpendicular axes. In addition, when components are particularly sensitive to the acoustic environment, an acoustic test shall be considered.

- a. Random Vibration - The test item is subjected to random vibration along each of three mutually perpendicular axes for one minute each. When possible, the component random vibration spectrum should be based on levels measured at the component mounting locations during previous subsystem or payload testing. When such measurements are not available, the levels should be based on statistically estimated responses of similar components on similar structures or on analysis of the payload.

Actual measurements should then be used if and when they become available. In the absence of any knowledge of the expected level, the generalized vibration test specification of Table 2.4-3 may be used.

As a minimum, all components shall be subjected to the levels of Table 2.4-4, which represent a workmanship screening test. The minimum workmanship test levels are primarily intended for use on electrical, electronic, and electromechanical hardware.

The test item shall be attached to the test equipment by a rigid fixture. The mounting shall simulate, insofar as practicable, the actual mounting of the item in the payload with particular attention given to duplicating the mounting contact area. In mating the test item to the fixture, a flight-type mounting (including vibration isolators or kinematic mounts, if part of the design) and fasteners should be used. Normally sealed items should be pressurized during test to their prelaunch pressure.

For components mounted on isolators, flexures, or other highly compliant mounting structure, adequate workmanship testing may not be achieved in the flight configuration. In this case, it may be necessary to test the component hard-mounted to the shaker to achieve sufficient input levels to verify workmanship. The hard-mounted test would be run in addition to testing the component with flight-like mounting hardware. The component must be assessed for the hard-mounted test configuration to ensure that the hardware can survive the test without damage.

In cases where significant changes in strength, stiffness, or applied load result from variations in internal and external pressure during the launch phase, a special test should be considered to cover those effects.

Prior to the test, a survey of the test fixture/exciter combination should be performed to evaluate the fixture dynamics, the proposed choice of control accelerometer locations, and the control strategy. The evaluation should include consideration of cross-axis responses. If a mechanical test or engineering model of the test article is available it should be included in the survey.

For very large components the random vibration tests may have to be supplemented or replaced by an acoustic test if the vibration test levels are insufficient to excite internal hardware. If neither the acoustic nor vibration excitation is sufficient to provide an adequate workmanship test, a screening program should be initiated at lower levels of assembly; down to the board level, if necessary. The need for the screening program must be evaluated by the project. The evaluation is based on mission reliability requirements and hardware criticality, as well as budgetary and schedule constraints.

If testing is performed below the component level of assembly, the workmanship test levels of Table 2.4-4 can be used as a starting point for test tailoring. The intent of testing at this level of assembly is to uncover design and workmanship flaws. The test input levels do not represent expected environments, but are intended to induce failure in weak parts and to expose workmanship errors. The susceptibility of the test item to vibration must be evaluated and the test level tailored so as not to induce unnecessary failures.

If the test levels create conditions that exceed appropriate design safety margins or cause unrealistic modes of failure, the input spectrum can be notched below the minimum workmanship level. This can be accomplished when flight or test responses at the higher level of assembly are known or when appropriate force limits have been calculated.

- b. Acoustic Test - If a component-level acoustic test is required, the test set-up and control should be in accordance with the requirements for payload testing.
- c. Performance - Before and after test exposure, the test item shall be examined and functionally tested. During the test, performance shall be monitored in accordance with the verification specification.

#### 2.4.2.6 Acceptance Requirements

Vibroacoustic testing for the acceptance of previously qualified hardware shall be conducted at flight limit levels using the same duration as recommended for protoflight hardware. As a minimum, the acoustic test level shall be 138 dB, and the random vibration levels shall represent the workmanship test levels.

The payload is subjected to an acoustic test and/or a random vibration test in three axes. Components shall be subjected to random vibration tests in the three axes. Additional vibroacoustic tests at subsystem/instrument and component levels of assembly are performed in accordance with the environmental verification plan or as required for delivery.

Hardware that has beryllium, composite (including metal matrix), ceramic, or bonded joints in the structural load path and whose strength margins are driven by vibro-acoustic loading shall be tested to protoflight levels for random and/or acoustic testing even if the design has been previously qualified on a valid prototype or protoflight unit. Protoflight vibro-acoustic testing ensures that structure whose strength is workmanship or fabrication dependent is adequately screened to preclude failure at higher levels of assembly. Protoflight testing should be performed at the lowest level of assembly practical for the hardware.

During the test, performance shall be monitored in accordance with the verification specification.

Table 2.4-3  
 Generalized Random Vibration Test Levels  
 Components (ELV)  
 22.7-kg (50-lb) or less

Frequency (Hz)	ASD Level (g <sup>2</sup> /Hz)	
	Qualification	Acceptance
20	0.026	0.013
20-50	+6 dB/oct	+6 dB/oct
50-800	0.16	0.08
800-2000	-6 dB/oct	-6 dB/oct
2000	0.026	0.013
Overall	14.1 G <sub>rms</sub>	10.0 G <sub>rms</sub>

The acceleration spectral density level may be reduced for components weighing more than 22.7-kg (50 lb) according to:

	<u>Weight in kg</u>	<u>Weight in lb</u>	
dB reduction	= 10 log(W/22.7)	10 log(W/50)	
ASD(50-800 Hz)	= 0.16•(22.7/W)	0.16•(50/W)	for protoflight
ASD(50-800 Hz)	= 0.08•(22.7/W)	0.08•(50/W)	for acceptance

Where W = component weight.

The slopes shall be maintained at + and - 6dB/oct for components weighing up to 59-kg (130-lb). Above that weight, the slopes shall be adjusted to maintain an ASD level of 0.01 g<sup>2</sup>/Hz at 20 and 2000 Hz.

For components weighing over 182-kg (400-lb), the test specification will be maintained at the level for 182-kg (400 pounds).

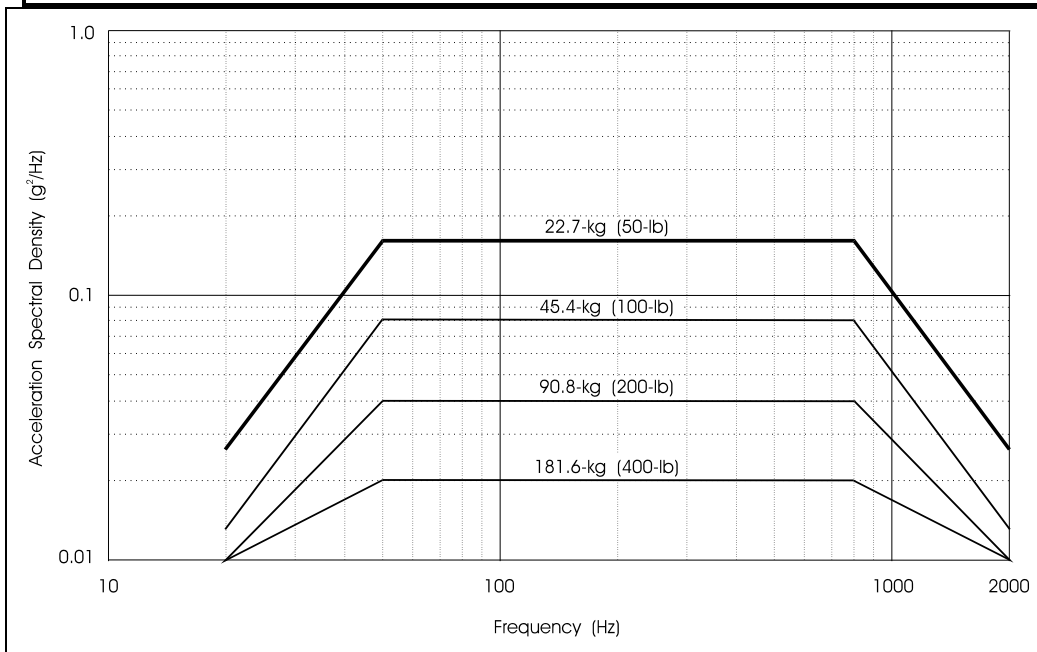

Check the GSFC Technical Standards Program website at <http://standards.gsfc.nasa.gov> or contact the Executive Secretary for the GSFC Technical Standards Program to verify that this is the correct version prior to use.

Table 2.4-4  
 Component Minimum Workmanship  
 Random Vibration Test Levels  
 45.4-kg (100-lb) or less

Frequency (Hz)	ASD Level (g <sup>2</sup> /Hz)
20	0.01
20-80	+3 dB/oct
80-500	0.04
500-2000	-3 dB/oct
2000	0.01
Overall	6.8 grms

The plateau acceleration spectral density level (ASD) may be reduced for components weighing between 45.4 and 182 kg, or 100 and 400 pounds according to the component weight (W) up to a maximum of 6 dB as follows:

	<u>Weight in kg</u>	<u>Weight in lb</u>
dB reduction	= $10 \log(W/45.4)$	= $10 \log(W/100)$
ASD <sub>(plateau)</sub> level	= $0.04 \cdot (45.4/W)$	= $0.04 \cdot (100/W)$

The sloped portions of the spectrum shall be maintained at plus and minus 3 dB/oct. Therefore, the lower and upper break points, or frequencies at the ends of the plateau become:

$F_L = 80 (45.4/W)$  [kg]      $F_L =$  frequency break point low end of plateau  
 =  $80 (100/W)$  [lb]

$F_H = 500 (W/45.4)$  [kg]      $F_H =$  frequency break point high end of plateau  
 =  $500 (W/100)$  [lb]

The test spectrum shall not go below 0.01 g<sup>2</sup>/Hz. For components whose weight is greater than 182-kg or 400 pounds, the workmanship test spectrum is 0.01 g<sup>2</sup>/Hz from 20 to 2000 Hz with an overall level of 4.4 g<sub>rms</sub>.

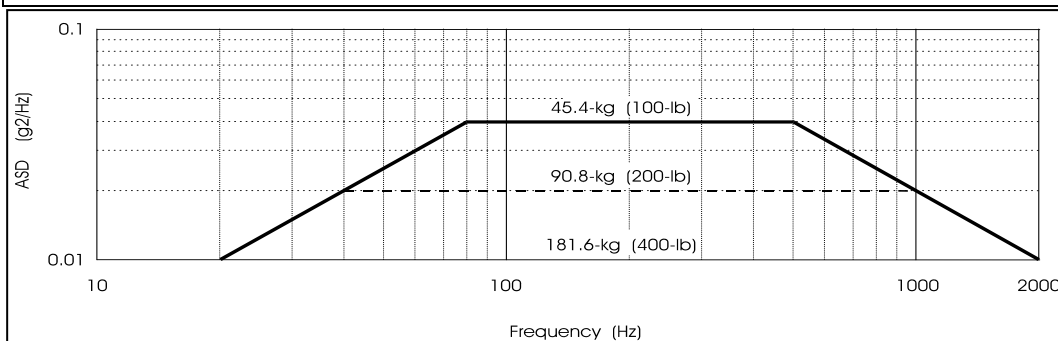

#### 2.4.2.7 Retest of Reflight Hardware

For reflight hardware, the amount of retest that is needed is determined by considering the amount of rework done after flight and by comparing the stresses of the upcoming flight with those of the previous flight. The principal objective is to verify the workmanship. If no disassembly and rework was done, the test may not be necessary. The effects of storage, elapsed time since last exposure, etc. should be considered in determining the need for retest. Subsystems that have been taken apart and reassembled should, as a minimum, be subjected to an acoustic test (levels shall be equal to the limit levels) and a random vibration test in at least one axis. More comprehensive exposures shall be considered if the rework has been extensive.

#### 2.4.2.8 Retest of Reworked Hardware

In many cases it is necessary to make modifications to hardware after a unit has been through a complete mechanical verification program. For example, replacing a capacitor on a circuit board in an electronics box that has already been through protoflight vibration testing. For this type of reworked hardware, the amount of additional mechanical testing required depends on the amount of rework done and the amount of disassembly performed as part of the rework. The primary objective of post-rework testing is to ensure proper workmanship has been achieved in performing the rework and in reassembling the component. As a minimum, the reworked component shall be subjected to a single axis workmanship random vibration test to the levels specified in Table 2.4-4. The determination of axis shall be made based on the direction necessary to provide the highest excitation of the reworked area. Testing may be required in more than one axis if a single axis test cannot be shown to adequately test all of the reworked area. If the amount of rework or disassembly required is significant, then 3-axis testing to acceptance levels may be necessary if they are higher than workmanship levels.

#### 2.4.3 Sinusoidal Sweep Vibration Qualification

Sine sweep vibration tests are performed to qualify prototype/protoflight hardware for the low-frequency transient or sustained sine environments when they are present in flight, and to provide a workmanship test for all payload hardware which is exposed to such environments and normally does not respond significantly to the vibroacoustic environment, such as wiring harnesses and stowed appendages.

For a payload level test, the payload shall be in a configuration representative of the time the stress occurs during flight, with appropriate flight type hardware used for attachment. For example, if the test is intended to simulate the vibration environment produced by the firing of retro/apogee motors, the vibration source shall be attached at the retro/apogee motor adapter, and the payload shall be in a configuration representative of the retro/apogee motor burning mode of operation.

In addition, all ELV payloads shall be subjected to swept sine vibration testing to simulate low-frequency sine transient vibration and sustained, pogo-like sine vibration (if expected) induced by the launch vehicle. Qualification for these environments requires swept sine vibration tests at the payload, instrument, and component levels of assembly.

It is understood that, for some payload projects, the sinusoidal sweep vibration qualification program may have to be modified. For example, for very large ELV payloads (with very large masses, extreme lengths, or large c.g. offsets) it may be impracticable because of test facility limitations to perform a swept sine vibration test at the payload level of assembly. In that case, testing at the highest level of assembly practicable is required.

For the sinusoidal vibration environment, limit levels shall be used which are consistent with the minimum probability level given in Table 2.4-2. The qualification level is then defined as the limit level times 1.25. The test input frequency range shall start be limited to the frequency range in which coupled loads results are applicable and may be used for notching test responses. The typical frequency range of the sine test is 5 to 50 Hz but the range of the test may be extended depending on the specific launch vehicle and the frequency content of the coupled loads analysis. The fatigue life considerations of 2.4.2.1 apply where hardware reliability goals demand the demonstration of a specific hardware lifetime. The sine sweep environmental test program shall be included in the environmental verification plan and environmental verification specification.

#### 2.4.3.1 ELV Payload Sine Sweep Vibration Tests

At the payload level of assembly, ELV prototype/protoflight hardware shall, when practicable, be subjected to a sine sweep vibration design qualification test to verify its ability to survive the low-frequency launch environment. The test also provides a workmanship vibration test for payload hardware which normally does not respond significantly to the vibroacoustic environment, but can experience significant responses from the ELV low-frequency sine transient vibration and any sustained, pogo-like sine vibration. Guidelines for developing mission-specific test levels are given in 2.4.3.1.b.

- a. Vibration Test Requirements - Protoflight hardware shall be subjected to a sine sweep vibration test to verify flightworthiness and workmanship. The test shall represent the qualification level (flight limit level times 1.25).

The test is intended for all ELV payloads (spacecraft) except those with very large masses, extreme lengths and/or large c.g. offsets, where it is impracticable because of test facility limitations.

If the sine sweep vibration test is not performed at the payload level of assembly, it should be performed at the next lowest practicable level of assembly.

The payload in its launch configuration should be attached to a vibration fixture by use of a flight-type launch-vehicle attach fitting (adapter) and attachment (separation system) hardware. Sine sweep vibration should be applied at the base of the adapter in each of three orthogonal axes, one of which is parallel to the thrust axis. The test sweep rate shall be 4 octaves per minute to simulate the flight sine transient vibration; lower sweep rates shall be used in the appropriate frequency bands as required to match the duration and rate of change of frequency of any flight sustained, pogo-like vibration. The frequency range of the sine test should be consistent with the frequency content of the launch vehicle coupled loads analysis. Mission-specific sine sweep test levels should be developed for each ELV payload. Guidelines for developing the test levels are given in 2.4.3.1.b.

Prior to the payload test, a survey of the test fixture/exciter combination should be performed to evaluate the fixture dynamics, the proposed choice of control accelerometer locations, and the control strategy. The evaluation should include consideration of cross-axis responses. If a mechanical test model of the payload is available it should be included in the survey to evaluate the need for limiting (or notching).

During the protoflight hardware sine sweep vibration test to the specified test levels, loads induced in the payload and/or adapter structure while sweeping through resonance shall not exceed 1.25 times flight limit loads. If required, test levels should

be reduced ("notched") at critical frequencies. Acceleration responses of specific critical items may also be limited to 1.25 times flight limit levels if required to preclude unrealistic levels, provided that the spacecraft model used for the coupled loads analysis has sufficient detail and that the specific responses are recovered (using the acceleration transformation matrix) from the coupled loads analysis results.

A low-level sine sweep shall be performed prior to the protoflight-level sine sweep test in each test axis. Data from the low-level sweeps measured at locations identified by a notching analysis shall be examined to determine if there are any significant test response deviations from analytical predictions. The data utilized shall include cross-axis response levels. Based on the results of the low-level tests, the predetermined notch levels shall be verified prior to the protoflight-level test. The flight limit loads used for notching analysis shall be based on the final verification cycle coupled loads analysis (including a test-verified payload model).

- b. Mission-Specific Test Level Development - Sinusoidal vibration test levels required to simulate the flight environment for ELV spacecraft vary with the payload attach fitting (adapter) and spacecraft configuration, including overall weight and length, mass and stiffness distributions, and axial-to-lateral coupling. It therefore is impracticable to specify generalized sine sweep vibration test levels applicable to all spacecraft, and mission-specific test levels must be developed for each ELV spacecraft based on the coupled loads analysis.

Coupled loads analysis results should be utilized to develop mission specific sinusoidal vibration test levels based on acceleration-response time histories or processed shock response spectra (SRS) data at the interface of the test article for all significant flight event loading conditions. Equivalent sine sweep vibration test input levels can be developed by processing the interface time history data using SRS techniques and then dividing the resulting SRS by the assumed Q (where  $Q=C_c/2C$ ). It should be noted that, in developing equivalent test input levels by dividing the SRS by Q, the assumption of a lower Q is more conservative. In the absence of test data, typical assumed values of Q are from 10 to 20. For pogo-like flight events, the use of SRS techniques is not generally required.

Prior to the availability of coupled loads analysis results, preliminary sine test levels may be estimated by using the ELV "user manual" sine vibration levels for spacecraft base drive analysis, with notching levels based on net loads equivalent to the user manual c.g. load factor loads. The base-drive analysis shall be truncated to a frequency range consistent with the launch vehicle coupled loads analysis. Alternatively, spacecraft interface dynamic response data from flight measurements or coupled loads analysis for similar spacecraft may be used for the base drive input in conjunction with a suitable uncertainty factor.

- c. Performance - Before and after each vibration test, the payload shall be examined and functionally tested. During the tests, performance shall be monitored in accordance with the verification specification.

#### 2.4.3.2 ELV Payload Subsystem and Component Sine Sweep Vibration Tests

As a screen for design and workmanship defects, these items (per Table 2.4-1) shall be subjected to a sine sweep vibration test along each of three mutually perpendicular axes. For the sinusoidal vibration environment, limit levels shall be defined to be consistent with the minimum probability level of Table 2.4-2. The protoflight qualification level is then defined as the limit level times 1.25. The test input frequency range shall be consistent with the

launch vehicle coupled loads analysis and shall be the same as the frequency range defined for payload testing. The fatigue life considerations of 2.4.2.1 apply where hardware reliability goals demand the demonstration of a specific hardware lifetime.

- a. Vibration Test Requirements - The test item in its launch configuration shall be attached to the test equipment by a rigid fixture. The mounting shall simulate, insofar as practicable, the actual mounting of the item in the payload, with particular attention given to duplicating the mounting interface. All connections to the item (connectors and harnesses, plumbing, etc.) should be simulated with lengths at least to the first tie-down point. In mating the test item to the fixture, a flight-type mounting (including vibration isolators or kinematic mounts, if part of the design) and fasteners, including torque levels and locking features, shall be used. Normally-sealed items shall be pressurized during test to their prelaunch pressure.

In cases where significant changes in strength, stiffness, or applied load result from variations in internal and external pressure during the launch phase, a special test shall be considered to cover those effects.

Sine sweep vibration shall be applied at the base of the test item in each of three mutually perpendicular axes. The test sweep rate shall be consistent with the payload-level sweep rate, i.e., 4 octaves per minute to simulate the flight sine transient vibration, and (if required) lower sweep rates in the appropriate frequency bands to match the duration and rate of change of frequency of any flight sustained, pogo-like vibration. The test shall be performed by sweeping the applied vibration once through the specified frequency range in each test axis.

Spacecraft subsystem, including instrument, and component levels depend on the type of structure to which the item is attached, the local attachment stiffness, the distance from the spacecraft separation plane, and the item's mass, size, and stiffness. It therefore is impracticable to specify generalized sine sweep vibration test levels applicable to all subsystems/instruments, and components, and mission-specific test levels shall be developed for each payload. Guidelines for developing the specific test levels are given in 2.4.3.2.b.

Prior to the test, a survey of the test fixture/exciter combination should be performed to evaluate the fixture dynamics, the proposed choice of control accelerometer locations, and the control strategy. The evaluation should include consideration of cross-axis responses. If a mechanical test or engineering model of the test article is available it should be included in the survey.

A low-level sine sweep shall be performed prior to the protoflight level sine sweep test in each test axis (with particular emphasis on cross-axis responses) to verify the control strategy and check test fixture dynamics.

- b. Mission Specific Test Level Development - The mission-specific sine sweep test levels for spacecraft subsystems/components should be based on test data from structural model spacecraft sine sweep tests if available. If not available, the test levels should be based on an envelope of two sets of responses:
  - (1) Coupled loads analysis dynamic responses should be utilized if acceleration-response time histories or processed shock response spectra (SRS) data are available at the test article location for all significant flight event loading conditions. Equivalent sine sweep vibration test input levels should be

developed using (SRS) techniques for transient flight events using the methods defined in 2.4.3.1.b.

- (2) Subsystem/component responses from a base drive analysis of the spacecraft and adapter, using the spacecraft sine sweep test levels as input (in three axes), should be included in the test level envelope. The base drive responses of the test article should be corrected for effects of the spacecraft test sweep rates if the sweep rates are not included in the base drive analysis input. Subsystem/component test sweep rates should match spacecraft test sweep rates.

Since most shakers can only apply translational (but not rotational) accelerations, for test articles with predicted large rotational responses it may be necessary to increase the test levels based on analysis to assure adequate response levels.

Also, for certain cases such as large items mounted on kinematic mount flexures, which experience both significant rotations and translations, it may be necessary to use the test article c.g. rotational and translational acceleration response levels as not-to-exceed test levels in conjunction with appropriate notching or limiting.

- c. Performance - Before and after test exposure, the test item shall be examined and functionally tested. During the test, performance shall be monitored in accordance with the verification specification.

#### 2.4.3.3 Acceptance Requirements

Sine sweep vibration testing for the acceptance of previously qualified hardware shall be conducted at the flight limit levels using the same sweep rates as used for protoflight hardware.

#### 2.4.4 Mechanical Shock Qualification

Both self-induced and externally induced shocks should be considered in defining the mechanical shock environment.

##### 2.4.4.1 Subsystem Mechanical Shock Tests

All subsystems, including instruments, shall be qualified for the mechanical shock environment.

- a. Self-Induced Shock - The subsystem should be exposed to self-induced shocks by actuation of all shock-producing devices. Self-induced shocks occur principally when pyrotechnic and pneumatic devices are actuated to release booms, solar arrays, protective covers, etc. Also the impact on deployable devices as they reach their operational position at the "end of travel" is a likely source of significant shock. When hardware contains such devices, it shall be exposed to each shock source twice to account for the scatter associated with the actuation of the same device. The internal spacecraft flight firing circuits should be used to trigger the event rather than external test firing circuits. At the project's discretion, this testing may be deferred to the payload level of assembly.
- b. Externally Induced Shock - Mechanical shocks originating from other subsystems, payloads, or launch vehicle operations must be assessed. When the most severe shock is externally induced, a suitable simulation of that shock shall be applied at the

subsystem interface. When it is feasible to apply this shock with a controllable shock-generating device, the qualification level shall be 1.4 times the maximum expected value at the subsystem interface, applied once in each of the three axes. A pulse or complex transient with a duration comparable to the actual shock pulse shall be applied at the test item interface along each of the three axes. The shock spectrum of the generated waveform (positive and negative) shall match the desired spectrum within the tolerances specified for mechanical shock in Section 1.13. Equalization of the shock spectrum is performed at a maximum resolution of one-sixth octave. The fraction of critical damping ( $c/c_c$ ) used in the shock spectral analysis of the test pulse should equal the fraction of critical damping used in the analysis of the data from which the test specification was derived. In the absence of a strong rationale for some other value, a fraction of critical damping equivalent to a Q of 10 shall be used for shock spectrum analysis.

If the project so chooses or if it is not feasible to apply the shock with a controllable shock-generating device (e.g. the subsystem is too large for the device), the test may be conducted at the payload level by actuating the devices in the payload that produce the shocks external to the subsystem to be tested. The shock-producing device(s) must be actuated a minimum of two times for this test.

The decision to perform component shock testing is typically based on an assessment of the shock susceptibility of the component and the expected shock levels. If the component is not considered shock sensitive and if there is low potential for damage due to the shock environment, then the project may choose to defer shock testing to the payload level of assembly. The potential for damage due to shock can be quantified based on Figure 2.4-1. Two curves are shown in the figure; one for standard aerospace electronics and one for all other hardware. If the flight shock environment as shown on an SRS plot ( $Q=10$ ) is enveloped by the appropriate curve shown in Figure 2.4-1, then the shock environment can be considered benign and there is low risk in deferring the shock test. For the case in which the shock levels are above the curve, then component level shock testing should be considered as the shock level may be high enough to cause damage. The curve provided in Figure 2.4-1 is intended as a guideline for determining whether component level shock testing should be performed. Each component should be evaluated individually to determine its susceptibility for damage due to the predicted shock environment.

It will not be necessary to conduct a test for externally induced shocks if it can be demonstrated that the shock spectrum of the self-induced environment is greater at all frequencies than the envelope of the spectra created by the external events at all locations within the subsystem.

- c. Test Setup - During test, the test item should be in the electrical and mechanical operational modes appropriate to the phase of mission operations when the shock will occur.
- d. Performance - Before and after the mechanical shock test, the test item shall be examined and functionally tested. During the tests, performance shall be monitored in accordance with the verification specification.

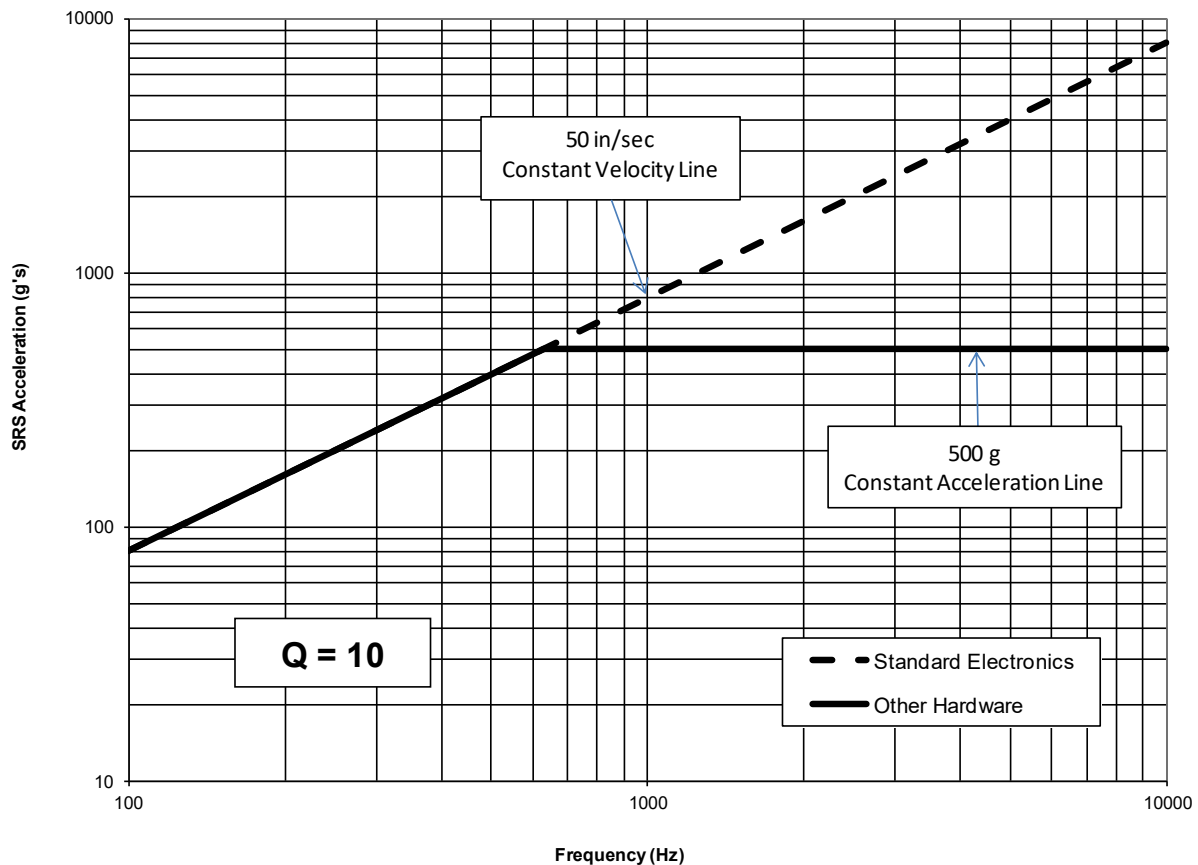

Figure 2.4-1 Shock Response Spectrum (SRS) for assessing Component Test Requirements

#### 2.4.4.2 Payload (Spacecraft) Mechanical Shock Tests

The payload must be qualified for the shock induced during payload separation (when applicable) and for any other externally induced shocks whose levels are not enveloped at the payload interface by the separation shock level. The payload separation shock is usually higher than other launch vehicle-induced shocks; however that is not always the case. For instance, the shocks induced at the payload interface during inertial upper stage (IUS) actuation can be greater. In addition, mechanical shock testing may be performed at the payload level of assembly to satisfy the subsystem mechanical shock requirements of 2.4.4.1.

- a. Other Payload (Spacecraft) Shocks - If launch vehicle induced shocks or shocks from other sources are not enveloped by the separation test, the spacecraft must be subjected to a test designed to simulate the greater environment. If a controllable source is used, the qualification level shall be 1.4 x the maximum expected level at the payload interface applied in each of the three axes. The simulated shock spectrum (positive and negative) shall match the desired test spectrum within the tolerances for mechanical shock specified in Section 1.13. The analysis should be performed with a fraction of critical damping corresponding to a Q of 10 or, if other than 10, with the Q for which the shock being simulated was analyzed.

The subsystem mechanical shock requirements may be satisfied by testing at the payload level of assembly as described above.

Check the GSFC Technical Standards Program website at <http://standards.gsfc.nasa.gov> or contact the Executive Secretary for the GSFC Technical Standards Program to verify that this is the correct version prior to use.

- b. Performance - Before and after the mechanical shock test, the test item shall be examined and functionally tested. During the tests, performance should be monitored in accordance with the verification test plan and specification.

#### 2.4.4.3 Acceptance Requirements

The need to perform mechanical shock tests for the acceptance of previously qualified hardware should be considered on a case-by-case basis. Testing should be given careful consideration evaluating mission reliability goals, shock severity, hardware susceptibility, design changes from the previous qualification configuration including proximity to the shock source, and previous history.

#### 2.4.5 Mechanical Function Verification

A kinematic analysis of all payload mechanical operations is required (a) to ensure that each mechanism can perform satisfactorily and has adequate margins under worst-case conditions, (b) to ensure that satisfactory clearances exist for both the stowed and operational configurations as well as during any mechanical operation, and (c) to ensure that all mechanical elements are capable of withstanding the worst-case loads that may be encountered. Payload qualification tests are required to demonstrate that the installation of each mechanical device is correct and that no problems exist that will prevent proper operation of the mechanism during mission life.

Subsystem qualification tests are required for each mechanical operation at nominal-, low-, and high-energy levels. To establish that functioning is proper for normal operations, the nominal test shall be conducted under the most probable conditions expected during normal flight. A high-energy test and a low-energy test shall also be conducted to prove positive margins of strength and function. The levels of these tests shall demonstrate margins beyond the nominal conditions by considering adverse interaction of potential extremes of parameters such as temperature, friction, spring forces, stiffness of electrical cabling or thermal insulation, and, when applicable, spin rate. Parameters to be varied during the high- and low-energy tests shall include, to the maximum extent practicable, all those that could substantively affect the operation of the mechanism as determined by the results of analytic predictions or development tests. As a minimum, successful operation at temperature extremes 10°C beyond the range of expected flight temperatures shall be demonstrated.

Lubricants susceptible to adverse effects from humidity, such as MoS<sub>2</sub> shall be given protection. Testing in a humid environment shall, where practicable, either be avoided or minimized.

#### 2.4.5.1 Life Testing

A life test program shall be implemented for mechanical elements that move repetitively as part of their normal function and whose useful life must be determined in order to verify their adequacy for the mission. The verification plan and the verification specification shall address the life test program, identifying the mechanical elements that require such testing, describing the test hardware that will be used, and the test methods that will be employed.

Life test planning should be initiated as early as possible in the development phase, and presented at each program system/peer review to allow enough time to complete the life test and thoroughly disassemble and inspect the mechanism, while retaining enough time to react to any anomalous findings. Once the plan is finalized, an independent peer review of the procedure and criteria should be held.

The life test mechanism should be fabricated and assembled such that it is as nearly identical as possible to the actual flight mechanism, with special attention to the development and implementation of detailed assembly procedures and certification logs. In fact, it is preferable that the life test mechanism actually be a flight spare or Qualification Unit. Careful attention should be given to properly simulating the flight interfaces, especially the perhaps less obvious details, such as the method of mounting of the mechanism, the preloading and/or clamping of bearings or other tribological interfaces, the routing of harnesses, the attachment of thermal blankets, and any other items that could have an influence on the performance of the mechanism.

Prior to the start of life testing, mechanisms should be subjected to the same ground testing environments, both structural and thermal, that are anticipated for the flight units (protoflight or acceptance levels, as appropriate). These environments may have a significant influence on the life test performance of the mechanism.

Consideration should be given to the geometry of the test set-up and the effects of gravity on the performance of the life test mechanism, including the effects on lubrication and external loads. For example, gravity may cause lubrication to puddle at the bottom of a bearing race or run out of the bearing. In some cases, the effects of gravity may cause abnormally high loads on the mechanism.

The thermal environment of the mechanism during the life test should be representative of the on-orbit environment. If expected bulk temperature changes are significant, then the life test should include a number of transitions from the hot on-orbit predictions to the cold on-orbit predictions, and vice versa. Depending on the thermal design, significant temperature gradients may be developed which could have a profound influence on the life of the mechanism and, therefore, should be factored into the thermal profile for the life test.

Consideration should be given to including in the life test the effects of vacuum on the performance of the mechanism with particular attention to its effects on the thermal environment (i.e., no convective heat transfer) and potentially adverse effects on lubrication and materials. Life testing in a gaseous nitrogen environment as an inexpensive alternative to a long duration vacuum test, for example, may have a completely unexpected or unanticipated effect on lubricant tribology.

Life testing of electrically powered devices should be conducted with nominal supply voltage.

The selection of the proper instrumentation for the life test is very important. Physical parameters that are an indication of the health of the mechanism should be closely monitored and trended during the life test. These parameters may include in-rush and steady-state currents, electrical opens or shorts, threshold voltages, temperatures (both steady-state and rate of change), torques, angular or linear positions, vibration, times of actuation and open/closed loop system responses.

The life test should be designed to "fail safe" in the event of any failure of the test setup, ground support equipment, or test article. There may be a severe impact to the life test results if it is necessary to stop a life test to replace or repair ground support equipment. Uninterruptible power supplies should be considered when required for autonomous shutdown without

damage to the test article or loss of test data. Redundant sensors should be provided for all critical test data. If used, the vacuum pumping station should be designed to maintain the integrity of the vacuum in the event of a sudden loss of power. Any autonomous data capture should include a time stamp to help diagnose the conditions present prior to a test shutdown.

The test spectrum for the life test should represent the required mission life for the flight mechanism, including both ground and on-orbit mechanism operations. In order to reduce test time and cost, the test spectrum should be simplified as much as possible while retaining an appropriate balance between realism and conservatism. It should include, if applicable, a representative range of velocities, number of direction reversals, and number of dead times or stop/start sequences between movements. Direction reversals and stop/start operations could have a significant effect on lubrication life, internal stresses, and, ultimately, the long term performance of the mechanism and therefore should be given priority in the development of the life test plan. Similarly, system dynamics effects due to inertial loads should be considered in development of the plan and implemented where appropriate, such as in applications where normal operation includes multiple start / stop or acceleration / deceleration maneuvers.

The minimum requirement for demonstrated life test operation without failure shall be 2.0 times the mission life. However, due to the uncertainties and simplifications inherent in the test, a marginally successful test requires post-test inspections and characterizations to extrapolate the remaining useful life. Because this can be difficult and uncertain, even higher margins should be considered if time permits in order to establish greater confidence due to the limited number of life test units that are typically available. Pre- and post-life test baseline performance tests should be conducted with clear requirements established for determining minimum acceptable performance at end-of-life.

When it is necessary to accelerate the life test in order to achieve the required life demonstration in the time available, caution must be exercised in increasing the speed or duty cycle of the mechanism. Mechanisms may survive a life test at a certain speed or duty cycle, but fail if the speed is increased or decreased, or if the duty cycle is increased significantly. There are three lubrication regimes to consider when considering whether to accelerate a life test, "boundary lubrication", "mixed lubrication", and "full elastohydrodynamic (EHD) lubrication".

For boundary and mixed lubrication regimes, the most likely failure mechanisms will be wear and lubricant breakdown, not fatigue. Unfortunately failure by wear is not an exact science; therefore, life test acceleration by increasing speed should be considered with caution. A mechanism that normally operates in these two regimes should never be accelerated in a life test to a level where the lubrication system moves into the EHD regime for the test. Acceleration of a life test for systems in boundary or mixed lubrication regimes may be considered if it can be shown by analysis or test that the mechanism rotor oscillations for the accelerated operation are similar to that during normal operation. For example, in a step motor, it should be shown that the rotor oscillations damp out to less than 10% of the peak overshoot amplitude prior to initiating the next accelerated step. Rationale for acceleration should be presented in the initial test plan.

In the EHD regime, no appreciable wear should occur and the failure mechanism should be material fatigue rather than wear. Therefore, while life test acceleration by increasing speed may be considered, other speed limiting factors must also be considered. For example, at the speed at which EHD lubrication is attained, one must be concerned with bearing retainer imbalances which may produce excessive wear of the retainer, which would in turn produce contaminants which could degrade the performance of the bearings. Additionally, thermal issues may arise related to increased power dissipation for higher speed operation, like increased bearing gradients, which should be thoroughly evaluated.

If there are significant downtimes associated with the operation of an intermittent mechanism, the life test can be accelerated by reducing this downtime, as long as this does not adversely affect temperatures and leaves enough "settle time" for the lubricant film to "squish out" of the contact area to simulate a full stop condition.

For all these reasons, the life test should be run as nearly as possible using the on-orbit speeds and duty cycles. In some cases it may not be possible to accelerate the test at all.

Upon completion of the life test, it is imperative that careful disassembly procedures are followed and that the proper levels of inspection are conducted. Successful tests will not have any anomalous conditions such as abnormal wear, significant lubrication breakdown, or excessive debris generation. These or other anomalous conditions may be cause for declaring the life test a failure despite completion of the required test spectrum. A thorough investigation of all moving components and wear surfaces should be conducted. This may include physical dimensional inspection of components, high magnification photography, lubricant analysis, Scanning Electron Microscope (SEM) analysis, etc. Photographic documentation of the life test article should be made from incoming component inspection/acceptance through full assembly to act as a baseline for comparison.

For those items determined not to require life testing, the rationale for eliminating the test must be provided along with a description of the analyses that will be done to verify the validity of the rationale. Caution should be exercised when citing heritage as a reason for not conducting a life test. Many factors such as assembly personnel, environments, changes to previously used processes, or "improvements" to the design may lead to subtle differences in the mechanism that in turn could affect the outcome of a life test. For example, environmental testing of the heritage mechanism may not actually have enveloped the predicted flight environment of the mechanism under consideration.

#### 2.4.5.2 Demonstration

Compliance with the mechanical function qualification requirements is demonstrated by a combination of analysis and testing. The functional qualification aspects of the demonstration are discussed below. The life test demonstrations are peculiar to the design and cannot be described here. Rather, they must be described in detail in an approved verification plan and verification specification.

- a. Analysis - An analysis of the payload should be conducted to ensure that satisfactory clearances exist for both the stowed and operational configurations. Therefore, in conjunction with the flight-loads analysis, an assessment of the relative displacements of the various payload elements with respect to other payloads and various elements of ELV payload fairing should be made for potentially critical events. During analysis, the following effects should be considered: an adverse build-up of tolerances, thermal distortions, and mechanical misalignments, as well as the effects of static and dynamic displacements induced by particular mission events.

In addition, a kinematic analysis of all deployment and retraction sequences should be conducted to ensure that each mechanism has adequate torque margin under worst-case friction conditions and is capable of withstanding the worst-case loads that may be encountered during unlatching, deployment, retraction, relatching, or ejection sequences. In addition, the analysis should verify that sufficient clearance exists during the motion of the mechanisms to avoid any interference.

The selection of lubricant for use in critical moving mechanical assemblies should be based upon development tests of the lubricant that demonstrate its ability to provide adequate lubrication under all specified operating conditions over the design lifetime. Since life testing cannot typically provide proof of lubricant availability based on evaporation over the required life of the mechanism, an analysis should be performed to show that there is an adequate amount of lubricant in the system (not including degradation) for the duration of the mechanism life with a margin greater than 10. Lubricant availability analyses based on degradation rates should be proven through life testing (see section 2.4.5.1).

The design of each ball bearing installation must be substantiated by analysis and either development tests or previous usage. The materials, stresses, stiffness, fatigue life, preload, and possible binding under normal, as well as the most severe combined loading conditions, and other expected environmental conditions should be considered. Alignments, fits, tolerances, thermal and load induced distortions, and other conditions should be considered in determining preload variations. Bearing fatigue life calculations shall be based on a survival probability of 99.95 percent when subjected to maximum time varying loads. For noncritical applications or deployables, if nonquiet running is acceptable, and the bearing material is 52100 Carbon Steel or 440C Stainless Steel, the mean Hertzian contact stress shall not exceed 2760 megapascals (400,000 psi) when subjected to the yield load. During operation, the mean Hertzian contact stress shall not exceed 2310 megapascals (335,000 psi). For materials other than these, a hertzian contact stress allowable shall be determined based on manufacturer recommendations with appropriate reduction factors for aerospace applications and approved by the responsible engineer.

In addition to the requirements stated above, bearing applications requiring quiet operation or low torque ripple should be designed so that the bearing race and ball stress levels are below the levels that would cause unacceptable permanent deformation during application of ascent loads. Where bearing deformation is required to carry a portion or all of the vehicle ascent loads, and where smoothness of operation is required on orbit, the mean Hertzian stress levels of the bearing steel (52100 and 440C) shall not exceed 2310 megapascals (335,000 psi) when subjected to the yield load. The upper and lower extremes of the contact ellipses shall be contained by the raceways. The stress and shoulder height requirements of the races shall be analyzed for both nominal and off-nominal bearing tolerances. During operation, the mean Hertzian contact stress should not exceed 830 megapascals (120,000 psi) over the worst case environment. For materials other than 52100 carbon steel and 440C stainless steel, a Hertzian contact stress allowable shall be determined based on manufacturer recommendations with appropriate reduction factors for aerospace applications and approved by the responsible engineer.

- b. Payload Testing - A series of mechanical function tests shall be performed on the payload to demonstrate "freedom-of-motion" of all appendages and other mechanical devices whose operation may be affected by the process of integrating them with the payload. The tests should demonstrate proper release, motion, and lock-in of each device, as appropriate, in order to ensure that no tolerance buildup, assembly error, or other problem will prevent proper operation of the mechanism during mission life. Unless the design of the device dictates otherwise, mechanical testing may be conducted in ambient laboratory conditions. The testing should be performed at an appropriate time in the payload environmental test sequence and, if any device is subsequently removed from the payload, the testing should be repeated after final reinstallation of the device.

- c. Subsystem Testing - Each subsystem, and instrument, that performs a mechanical operation must undergo functional qualification testing. At the project's discretion, however, such testing may be performed at the payload level of assembly. The test is conducted after any other testing that may affect mechanical operation. The purpose is to confirm proper performance and to ensure that no degradation has occurred during the previous tests.

During the test, the electrical and mechanical components of the subsystem should be in the appropriate operational mode. The subsystem is also exposed to pertinent environmental effects that may occur before and during mechanical operation. The verification specification should stipulate the tests to be conducted, the necessary environmental conditioning, and the range of required operations.

It is desirable that preliminary mechanical function tests and exploratory design development tests shall have been performed with a structural model prior to qualification testing of the subsystem. Such tests uncover weaknesses, detect failure modes, and allow time before protoflight testing to develop and institute quality control procedures and corrective redesign.

- (1) Information Requirements - The following information is necessary to define the series of functional qualification tests:
- o A description of mission requirements, how the mechanism is intended to operate, and when operation occurs during the mission;
  - o The required range of acceptable operation and criteria for acceptable performance;
  - o The anticipated variation of all pertinent flight conditions or other parameters that may affect performance.
- (2) Test Levels and Margins - For each mechanical operation, such as appendage deployment, tests at nominal-, low-, and high-energy levels shall be performed. One test shall be conducted at the most probable level that will occur during a normal mission (the nominal level). The test will establish that functioning is proper for nominal operating conditions and baseline measurements will be obtained for subsequent tests.

Other tests shall be conducted to prove positive margins of strength and function, including torque or force ratio, a high-energy test and a low-energy test. The levels of these tests shall demonstrate margins beyond the nominal operational limits over the full range of motion at the worst case environments and the operating parameters of the system (rate, acceleration, etc.). The margins shall not be selected arbitrarily, but shall take into account all the uncertainties of operation, strength, and test. If a margin test cannot be conducted at the subsystem level due to its size and complexity these verification tests shall be performed at the highest level of assembly possible and the results combined to provide subsystem performance.

While in an appropriate functional configuration the hardware should be subjected to events such as separation, appendage deployment, retromotor ejection, or other mechanical operations, such as spin-up or despin that are associated with the particular mission.

Gravity compensation should be provided to the extent necessary to achieve the test objectives. As a guide, the uncompensated gravity effects should be less than 10 percent of the operational loads. Uncompensated gravity of 0.1 g is usually achievable and acceptable for separation tests and for comparative measurements of appendage positioning if the direction is correct, i.e., the net shear and moment imposed during measurements acts in the same direction as it would in flight, thereby causing any mechanism with backlash to assume the correct extreme positions. For testing of certain mechanical functions, however, more stringent uncompensated gravity constraints may be required. When appropriate, the subsystem should be preconditioned before test or conditioned during test to pertinent environmental levels. This can include vibration, high- and low-temperature cycling, pressure-time profiles, transportation and handling.

- (3) Performance - Before and after test, the subsystem should be examined and electrically tested. During the test, the subsystem performance should be monitored in accordance with the verification specification.
- (4) Component Characterization and Testing – For applications where motor performance is critical to mission success, the design shall be based on a complete motor characterization at the minimum and maximum voltages from the spacecraft bus and motor driver and shall include as a minimum: rotor inertia, friction and damping parameters, back-EMF constant or torque constant, time constant, torque characteristics, speed versus torque curves, thermal dissipation, temperature effects, and where applicable, analysis to demonstrate adequate margin against back driving.

For applications where the motor is integrated into a higher assembly, the motor characterization shall be performed at the motor level prior to integration.

After initial functional testing, a run-in test should be performed on each moving mechanical assembly before it is subjected to further acceptance testing, unless it can be shown that this procedure would be detrimental to performance and would result in reduced reliability. The primary purpose of the run-in test is to detect material and workmanship defects that occur early in the component life. Another purpose is to wear-in parts of the moving mechanical assembly so that they perform in a consistent and controlled manner. Satisfactory wear-in may be manifested by a reduction in running friction to a consistent low level. The run-in test should be conducted for a minimum of 50 hours except for items where the number of cycles of operation, rather than hours of operation, is a more appropriate measure of the capability to perform in a consistent and controlled manner. For these units, the run-in test should be for at least 15 cycles or 5% of the total expected life cycles, whichever is greater. The run-in test conditions should be representative of the operational loads, speed, and environment; however, operation of the assembly at ambient conditions may be conducted if the test objectives can be met and the ambient environment will not degrade reliability or cause unacceptable changes to occur within the equipment such as generation of excessive debris. During the run-in test, sufficient periodic measurements should be made to indicate what conditions may be changing with time and what wear rate characteristics exist. Test procedures, test time, and criteria for performance adequacy should be in accordance with an approved test plan. All gear trains using solid or liquid lubricants should, where practicable, be inspected and cleaned following the run-in test.

### 2.4.5.3 Torque/Force Margin

The torque or force margin shall be demonstrated by test to be sufficiently large to guarantee system-performance under worst-case conditions throughout its life by fully accommodating the uncertainty in the resisting forces or torques and in the source of energy.

The Torque Margin (TM) is a measure of the degree to which the torque available to accomplish a mechanical function exceeds the torque required. The torque margin is generally the ratio of the driving or available torques times an appropriate Factor of Safety (FS) minus one. The torque margin requirement defined below applies to all mechanical functions, those driven by motors as well as springs, etc. at beginning of life (BOL) only; end of life (EOL) mechanism performance is determined by life testing as discussed in paragraph 2.4.5.1, and/or by analysis; however, all torque increases due to life test results should be included in the final TM calculation and verification. Positive margin ( $>0$ ) using the TM equation and FS stated herein must be shown for worst case EOL predicted conditions and at the extreme operating parameters of the system (rate, acceleration, etc.). For linear devices, the term "force" should replace "torque" throughout the section.

For final design verification, the torque margin shall be verified by testing the qualification (or protoflight) unit both before and after exposure to qualification level environmental testing. The torque margin on all flight units should also be verified by testing when possible (without breaking the flight hardware configuration), both before and after exposure to acceptance level environmental testing. All torque margin testing should be performed at the highest possible level of assembly, throughout the mechanism's range of travel, under worst-case predicted EOL environmental conditions, representing the worst-case combination of maximum and/or minimum predicted (not qualification) temperatures, gradients, positions, acceleration/ deceleration of load, rate, voltage, vacuum, etc. As the deviation from these worst case conditions increases, a higher Factor of Safety than that stated below should be used.

Along with system level test, available torque ( $T_{avail}$ ) and resistive torque ( $T_r$ ) under worst case conditions should be determined, whenever possible, through component, system and subsystem level tests. Torque ratios for gear driven systems should be verified, using subsystem level results, on both sides of the geartrain. The minimum available torque for these types of systems should never be less than 1 in-oz at the motor. Kick-off springs that do not operate over the entire range of the mechanical function can be neglected when computing available torque over the full range. However, the use of kick-off spring forces in the Torque Margin calculation at the beginning of travel or initial separation is acceptable. A Factor of Safety of at least 1.5 over inertial driven or known quantifiable resistive torques (that do not change over the operating life of the unit) shall be used in the final computing of torque margin as indicated in the table below. FS requirements for parasitic forces dominated by a combination of variable items should be determined based on the program phase as indicated in the table below. The final test verified Torque Margin shall be greater than zero ( $>0$ ) based on the FS listed for the Acceptance / Qualification Test phase.

Program Phase	Known Torque Factor of Safety (FS <sub>k</sub> )	Variable Torque Factor of Safety (FS <sub>v</sub> )
Preliminary Design Review	2.00	4.0
Critical Design Review	1.50	3.0
Acceptance / Qualification Test	1.50	2.0

For those cases where high confidence does not exist in determination of worst case load or driving capability, a Safety Factor higher than that stated above may be appropriate. Factors of Safety should be based on a confidence level determined from the quantity and fidelity of heritage and program test data. At the program PDR, a detailed plan to determine torque margin shall be presented. By CDR, it shall be demonstrated (see GEVS section 2.4.5.2) that the detail design complies with the program requirements as outlined in this section.

The required Factors of Safety should be appropriately higher than given above if:

- a. The designs involve an unusually large degree of uncertainty in the characterization of resistive torques.
- b. The torque margin testing is not performed in the required environmental conditions or is not repeatable and has a large tolerance band.
- c. The torque margin testing is performed only at the component level.

It is important to note that this torque margin requirement relates to the verification phase of the hardware in question. Conservative decisions should be made during the design phase to ensure adequate margins will be realized. However, it is recognized that under some unique circumstances these specified Factors of Safety might be detrimental (excessive) to the design of a system. For these specific cases which require approval of a waiver, appropriate Factors of Safety shall be determined based on the design complexity, engineering test data, confidence level, and other pertinent information.

The minimum available driving torque for the mechanism shall be determined based on the FS listed above. The Torque Margin (TM) shall be greater than zero and shall be calculated using the following formula:

$$TM = \{T_{avail} / (FS_k \Sigma T_{known} + FS_v \Sigma T_{variable})\} - 1$$

Where:

Driving Torques:

$T_{avail}$  = Minimum Available Torque or Force generated by the mechanism at worst case environmental conditions at any time in its life. If motors are used in the system,  $T_{avail}$  shall be determined at the output of the motor, not including gear heads or gear trains at its output based on minimum supplied motor voltage.  $T_{avail}$  similarly applies to other actuators such as springs, pyrotechnics, solenoids, heat actuated devices, etc.

Resistive Torques:

$\Sigma T_{known}$  = Sum of the fixed torques or forces that are known and quantifiable such as accelerated inertias ( $T=I\alpha$ ) and not influenced by friction, temperature, life, etc. A constant Safety Factor is applied to the calculated torque.

$\Sigma T_{variable}$  = Sum of the torques or forces that may vary over environmental conditions and life such as static or dynamic friction, alignment effects, latching forces, wire harness loads, damper drag, variations in lubricant effectiveness, including degradation or depletion of lubricant over life, etc.

#### 2.4.5.4 Acceptance Requirements

For the acceptance testing of previously qualified hardware, the payload and subsystem tests described in 2.4.5.2.b and 2.4.5.2.c shall be performed, except that the subsystem tests need be performed only at the nominal energy level. Adequate torque ratio (margin) shall be demonstrated for all flight mechanisms.

#### 2.4.6 Pressure Profile Qualification

The need for a pressure profile test should be assessed for all subsystems. A qualification test will be required if analysis does not indicate a positive margin at loads equal to twice those induced by the maximum expected pressure differential during launch. If a test is required, the limit pressure profile is determined by the predicted pressure-time profile for the nominal trajectory of the particular mission.

Because pressure-induced loads vary with the square of the rate of change, the qualification pressure profile is determined by multiplying the predicted pressure rate of change by a factor of 1.12 (the square root of 1.25, the required qualification factor on load).

##### 2.4.6.1 Demonstration

The hardware is qualified for the pressure profile environment by analysis and/or test. An analysis shall be performed to estimate the pressure differential induced by the nominal launch trajectories, as appropriate, across elements susceptible to such loading (e.g. thermal blankets, contamination enclosures, and housings of components). If analysis does not indicate a positive margin at loads equal to twice those induced by the maximum expected pressure differential, testing is required. Although testing at the subsystem level is usually appropriate, the project may elect to test at the payload level of assembly.

- a. Test Profile - The flight pressure profile shall be determined by the analytically predicted pressure-time history inside the cargo bay (or payload fairing) for the nominal launch trajectory for the mission (including reentry if appropriate). Because pressure-induced loads vary as the square of the pressure rate, the pressure profile for qualification is determined by increasing the predicted flight rate by a factor of 1.12 (square root of 1.25, the required test factor for loads). The pressure profile shall be applied once.
- b. Facility Considerations - Loads induced by the changing pressure environment are affected both by the pressure change rate and the venting area. Because the exact times of occurrence of the maximum pressure differential is not always coincident with the maximum rate of change, the pumping capacity of the facility must be capable of matching the desired pressure profile within  $\pm 5\%$  at all times.
- c. Test Setup - During the test, the subsystem shall be in the electrical and mechanical operational modes that are appropriate for the event being simulated.
- d. Performance - Before and after the pressure profile test, the subsystem shall be examined and functionally tested. During the tests, performance shall be monitored in accordance with the verification specification.

##### 2.4.6.2 Acceptance Requirements

Pressure profile test requirements do not apply for the acceptance testing of previously qualified hardware.

##### 2.4.7 Mass Properties Verification

Hardware mass property requirements are mission-dependent and, therefore, are determined on a case-by-case basis. The mass properties program should include an analytic assessment of the payload's ability to comply with the mission requirements, supplemented as necessary by measurement.

#### 2.4.7.1 Demonstration

The mass properties of the payload are verified by analysis and/or measurement.

When mass properties are to be derived by analysis, it may be necessary to make some direct measurements of subsystems and components in order to attain the accuracy required for the mission and to ensure that analytical determination of payload mass properties is feasible. Determination of the various subsystem properties should be sufficiently accurate that, when combined analytically to derive the mass properties of the payload, the uncertainties will be small enough to ensure compliance with payload mass property requirements. If analytic determination of payload mass properties is not feasible, then direct measurement is required. The following mass properties must be determined:

- a. Weight, Center of Gravity, and Moment of Inertia - Weight, center of gravity, and moment of inertia are used in predicting payload performance during launch, insertion into orbit, and orbital operations. The parameters are determined for all configurations to evaluate flight performance in accordance with mission requirements.
- b. Balance - Hardware is balanced in accordance with mission requirements. Balance may be achieved analytically, if necessary, with the aid of direct measurements.
  - (1) Procedure for Direct Measurement - The usual procedure for direct measurement is to perform an initial balance before beginning the environmental verification program and a final balance after completing the program. One purpose of the initial balance is to ensure the feasibility of attaining the stipulated final balance. A residual unbalance of not more than four times the final balance requirement is the recommended objective of initial balance. Another reason for doing the initial balance prior to environmental exposures is to evaluate the method of attaching the balance weights and the effect of the weights on the operation of the hardware during the environmental exposures. Final balance is done after completion of all environmental testing in order to properly adjust for all changes to weight distribution made during the verification program such as hardware replacement or redesign.
  - (2) Maintaining Balance - It is recommended that changes to the hardware that may affect weight distribution be minimized after completion of final balance. The effects of such changes (including any disassembly, hardware substitution, etc.) on the residual unbalance of the hardware should be assessed. That involves sufficient dimensional measurement and mass properties determination to permit a judgment as to whether the configuration changes have caused the residual unbalance to exceed requirements. If so, additional balance operations may be necessary.
  - (3) Correcting Unbalance - To correct unbalance, weights may be attached, removed, or relocated. The amount of residual unbalance for all appropriate configurations is determined and recorded for comparison with the balance requirements of the verification specification. Balance operations include interface, fit, and alignment checks as necessary to ensure that alignment of geometric axes is comparable with requirements.

Balancing operations include measurement and tabulation of weights and mass center locations (referenced to hardware coordinates) of appendages, motors, and other elements that may not be assembled for balancing.

The data is analyzed to determine unbalance contributed by such elements to each appropriate configuration.

The facilities and procedures for balancing should be fully defined at the time of initial balance, and sufficient exploratory balancing operations should be performed to provide confidence that the final balance can be accomplished satisfactorily and expeditiously.

#### 2.4.7.2 Acceptance Requirements

The mass property requirements cited above apply to all flight hardware.

SECTION 2.5

EMC

## 2.5 ELECTROMAGNETIC COMPATIBILITY (EMC) REQUIREMENTS

This section establishes interface and associated verification requirements for the control of electromagnetic interference (EMI) emission and susceptibility characteristics of electronic, electrical, and electromechanical equipment and subsystems designed or procured for use on GSFC Spacecraft.

This section is intended to provide guidance to each project for creating its own dedicated EMC Control Plan (EMCCP) or equivalent document that defines its electromagnetic environment and its requirements that have been tailored to that environment. The project EMCCP should be updated and maintained throughout the program.

Additional EMC documentation is provided on the GSFC EMC Working Group SPACES site, maintained by Code 565, Electrical Systems Branch, GSFC:

<https://spaces.gsfc.nasa.gov/display/EMCWG/Home>

The GSFC EMC Working Group SPACES page includes all of the reference documents listed in Section 2.5.1.1 as well as documentation of lessons learned from previous programs. Organizations outside of GSFC should contact their GSFC EMC representative in order to obtain the information available on this SPACES site.

This section of the document is organized as follows:

- Section 2.5.1 defines the general requirements, including test facility and procedure requirements;
- Section 2.5.2 defines the detailed requirements;
- Section 2.5.3 provides an Application Guide, which includes a discussion and rationale of the general and detailed requirements

### 2.5.1. General Requirements

The general requirements for EMC are as follows:

- a. The payload (spacecraft) and its elements must not generate EMI that could adversely affect its own subsystems and components, other payloads, or the safety and operation of the launch vehicle and launch site.
- b. The payload (spacecraft) and its subsystems and components should not be susceptible to emissions that could adversely affect their safety and performance. This applies whether the emissions are self-generated or emanate from other sources, or whether they are intentional or unintentional.

### 2.5.1.1 Documentation

All of the reference documents listed in this section are available on the “Documents” page of the GSFC EMC Working Group SPACES site:

<https://spaces.gsfc.nasa.gov/display/EMCWG/Home>.

The EMI test requirements in this document are based primarily on the requirements and test methods of the following document:

MIL-STD-461G	Requirements for the Control of Electromagnetic Interference Characteristics of Subsystems and Equipment, 11 December 2015
--------------	--

As needed, this document also references requirements, test methods, and tailoring guidelines provided in the following documents:

MIL-STD-461C	Electromagnetic Emission and Susceptibility Requirements for the Control of Electromagnetic Interference, 4 August 1986
--------------	---

MIL-STD-462, Notice 2	Electromagnetic Interference Characteristics, Measurement of, 1 May 1970
-----------------------	--

MIL-STD-464C	Electromagnetic Environmental Effects Requirements for Systems, 1 December 2010
--------------	---

SL-E-0002, Book 3	Space Shuttle Specification, Electromagnetic Interference Characteristics, Requirements for Equipment, 10 August 2001
-------------------	---

AIAA S-121A-2017	Electromagnetic Compatibility Requirements for Space Equipment and Systems
------------------	--

(no document number)	The Design, Construction and Test of Magnetically Clean Spacecraft - A Practical Guide (Mario H. Acuña)
----------------------	---

NASA-STD-8739.12	NASA Technical Standard for Metrology and Calibration
------------------	---

GPR-87390.1M	Goddard Procedural Requirement - Metrology: Control of Measuring and Test Equipment
--------------	---

Guidelines for grounding, bonding, and shielding are provided in the following documents:

NASA-HDBK-4001	Electrical Grounding Architecture for Unmanned Spacecraft
----------------	---

NASA-STD-4003	Electrical Bonding for NASA Launch Vehicles, Spacecraft, Payloads, and Flight Equipment
---------------	---

MIL-HDBK-419A	Grounding, Bonding, and Shielding for Electronic Equipments and Facilities (Volumes 1 & 2, 29 December 1987)
---------------	--

MIL-HDBK-1857	Grounding, Bonding and Shielding Design Practices
---------------	---

Check the GSFC Technical Standards Program website at <http://standards.gsfc.nasa.gov> or contact the Executive Secretary for the GSFC Technical Standards Program to verify that this is the correct version prior to use.

Guidelines for addressing Space Charging effects are provided in the following document:

NASA-HDBK-4002      Mitigating In-Space Charging Effects - A Guideline

Guidelines for assessing Launch Vehicle & Launch Site Electromagnetic Environments are provided in the following document:

ELVL-2010-0042300      Electromagnetic Environments – A Guideline for Spacecraft Launching from Eastern, Western and Pacific Ranges

Guidelines for assessing on-orbit RF environments are provided in the following document:

JSC-CR-06-070      Space Vehicle RF Environments

International Space Station (ISS) Payloads must comply with the EMI/EMC requirements defined in the following ISS documents:

SSP 57000      Pressurized Payloads Interface Requirements Document

SSP 57003      External Payload Interface Requirements Document

SSP 30237      Space Station Electromagnetic Emission and Susceptibility Requirements

SSP 30238      Space Station Electromagnetic Techniques

SSP 30240      Space Station Grounding Requirements

SSP 30242      Space Station Cable/Wire Design and Control Requirements for Electromagnetic Compatibility

SSP 30245      Space Station Electrical Bonding Requirements

The latest versions of these documents are available on the ISS Electronic Document Management System (EDMS):

<https://iss-www.jsc.nasa.gov/nwo/apps/edms/web/EDMS-RequestAccount.shtml>

### 2.5.1.2 Requirements Overview

Requirements and tests are prescribed at the component, subsystem, and payload levels of assembly. Not all requirements apply to all levels of assembly or to all types of payloads. The project must select the requirements that fit the characteristics of the mission and hardware. For example, a transmitter would require a different group of EMI tests than a receiver.

It is recommended that all flight hardware be tested at the component or subsystem level. Tests at this level are designed to assess the risk of interference at higher levels of assembly; as such, they are called EMI tests. The EMI test program is meant to uncover design flaws, workmanship defects, and unit-to-unit variations. These component/subsystem level EMI tests are the primary focus of this document.

The EMI tests are intended to verify that the design and workmanship of each component will be compatible with its intended/predicted electromagnetic environments. All tests must simulate the flight configuration to the extent feasible. The tests are performed to fixed levels which are intended to envelope those that may be expected during a typical mission and allow for some degradation of the hardware during the mission.

The levels should be tailored by the project EMC engineer(s) to accommodate mission-specific requirements, as explicitly recommended in MIL-STD-461G Section 1.2.2:

“Application-specific environmental criteria may be derived from operational and engineering analyses on equipment or subsystems being procured for use in specific systems or platforms. When analyses reveal that the requirements in this standard are not appropriate for that procurement, the requirements may be tailored and incorporated into the request-for-proposal, specification, contract, order, and so forth, prior to the start of the test program. The test procedures contained in this document should be adapted by the testing activity for each application.”

Such requirements, as defined in the appropriate mission-specific documentation, may include:

- platform-specific environments
- launch vehicle and launch site environments
- protection of sensitive detectors or instruments in the payload
- environments encountered during ground testing that may differ from expected on-orbit environments

Thus tailored, the requirements envelope the worst-case environments encountered during all phases of the program. However, because some payloads may have sensors and devices that are particularly sensitive to the low-level EMI ground environment, special workaround procedures may have to be developed in order to meet individual payload needs. Testing at the payload, spacecraft, and observatory levels are designed to assess compatibility at these higher levels of assembly; as such, they are called EMC tests.

Historically, GEVS has addressed GSFC platforms that tend to use “one of a kind” flight hardware developed specifically for a given mission. In such cases, it is recommended that each “one of a kind” component be thoroughly tested at component level.

By contrast, MIL-STD-461, which GEVS uses as its point of departure, largely addresses equipment developed for military platforms. In many cases, a vendor may be mass-producing a component that is intended to be used on as many platforms as possible. In these cases, testing each individual unit is impractical and cost prohibitive. One or more representative units are selected for testing, and the remaining units are “build to print” copies that are qualified by similarity.

Some recent GSFC programs have used multiple copies of components and/or used build-to-print copies of components used on previous missions. On such programs, a hybrid approach is recommended. Full testing should be performed on a representative unit, and the remaining units should be subjected, at minimum, to the following tests:

- Conducted Emissions, Power Leads, Differential Mode (section 2.5.2.1.1)
- Conducted Emissions, Common Mode, Power and Signal Lines (section 2.5.2.1.2)\*
- Conducted Susceptibility, Primary Power Leads, 30 Hz to 150 kHz (section 2.5.2.2.1)
- Conducted Susceptibility, Primary Power Leads, 150 kHz to 50 MHz (Section 2.5.2.2.4.2)
- Conducted Susceptibility, Power and Signal Cables, Common Mode, 10 kHz to 200 MHz (section 2.5.2.2.4.1)\*

*\* For the Common Mode tests, where multiple signal cables of the same type and interface circuitry (e.g. SpaceWire, redundant signal, etc.) exist on a particular box, only one of each representative type need be tested.*

A significant advantage is that the above tests may be performed in the component’s development laboratory; they need not be performed in an EMI chamber.

Guidelines for defining system level EMC testing are provided in MIL-STD-464C, Electromagnetic Environmental Effects Requirements for Systems. Such EMC testing may include, but is not necessarily limited to, the following tests:

- Power quality
- Aggregate radiated emissions, electric field
- Aggregate radiated susceptibility, electric field
- System self-compatibility

Further details for system level EMC tests are provided in section 2.5.2.5.

Test programs at these higher levels of assembly must be developed on a case-by-case basis according to the needs of each platform. Additional guidelines are provided on the GSFC EMC Working Group SPACES site:

<https://spaces.gsfc.nasa.gov/display/EMCWG/Home>

### 2.5.1.3 Testing at Lower Levels of Assembly

EMI testing must be performed at the component and subsystem levels of assembly, followed by EMC testing at the payload, spacecraft, and/or observatory levels as determined by the specific needs of the platform. In addition, it is recommended that diagnostic testing be performed at the circuit board level to the extent feasible. If possible, such testing should be performed at the breadboard level in order to identify and correct problems as early as possible before finalizing the flight design.

Testing at lower levels of assembly has many advantages, including:

- Detection of problems early in the program when they are less costly to correct, less disruptive to the program schedule, and more easily diagnosed and addressed than at higher levels of assembly;
- Providing a baseline and troubleshooting aid that can be used to alert the project to potential problems at higher levels of assembly

### 2.5.1.4 Safety and Controls

During prelaunch and prerelease checkout, sensitive detectors and hardware may require special procedures to protect them from the damage of high-level radiated emissions. If such procedures are needed, they should also be applied during EMI testing. Operational control procedures should also be instituted for EMI testing during prerelease checkout to minimize interference with other equipment as appropriate.

The requirements documented within the EMCCP and/or levied in component/sub-system specifications represent the environment in which the equipment must function and meet its performance requirements. All requirements will be satisfied. Spurious emissions or susceptibilities determined non-compliant with requirements will be eliminated or reduced to sufficient levels to satisfy original requirements with adequate margin. All data/analysis presented for component/sub-system qualification will be subject to technical board review by GSFC EMC engineers and evaluated for compatibility within the intended payload system. GSFC EMC Engineering reserves the right to make final determination of qualification. Any EUT judged non-compliant by this review board is required either to make corrective actions or to follow the waiver process described in section 2.5.1.6.4.

### 2.5.1.5 Test Facility and Procedure Requirements

The test facility and procedure requirements defined in MIL-STD-461G Section 4.3 will apply with modifications to the following requirements as discussed in the following subsections:

- Ambient electromagnetic level (MIL-STD-461G Section 4.3.4)
- Power source impedance (MIL-STD-461G Section 4.3.6)
- Construction and arrangement of EUT cables (MIL-STD-461G Section 4.3.8.6)
- Susceptibility testing (MIL-STD-461G Section 4.3.10.4)
- General test setup (MIL-STD-461G Figure 2)

Check the GSFC Technical Standards Program website at <http://standards.gsfc.nasa.gov> or contact the Executive Secretary for the GSFC Technical Standards Program to verify that this is the correct version prior to use.

MIL-STD-461G also provides guidance on the following topics that do not appear in earlier versions:

- Use of Fast Fourier Transform (FFT) receivers for emissions testing: FFT receivers have been demonstrated to perform emissions testing significantly more quickly and efficiently than traditional frequency swept techniques. MIL-STD-461G provides requirements for performing FFT measurements correctly and consistently with existing measurement techniques.
- Calibration of measuring equipment: Per MIL-STD-461G section 4.3.11, primary measurement devices and accessories required for measurement must be calibrated in accordance with an approved calibration program traceable to the National Institute for Standards and Technology (NIST). After the initial calibration passive devices such as measurement antennas, current probes, and LISNs, require no further formal calibration unless the device is repaired. The measurement system integrity check in the procedures is sufficient to determine acceptability of passive devices. Further guidance on adhering to calibration requirements is given in NASA-STD-8739.12 and GPR 8730.1M.

Additional discussions of these requirements are provided in Section 2.5.3.2.

Any deviations from these requirements must be approved by the project EMC engineer(s) and documented in the project EMCCP.

#### 2.5.1.5.1 Ambient Electromagnetic Level

The ambient electromagnetic level must be measured with the EUT de-energized and all Electrical Ground Support Equipment (EGSE) powered on. If necessary, ambient conducted levels on power leads will be measured with the leads disconnected from the EUT and connected to a resistive load which draws the same rated current as the EUT. The ambient level must be verified to be at least 6 dB below the specified limits and recorded in the EMI Test Report (EMITR) prior to performing any emissions measurements on the EUT.

These requirements override the following statement from MIL-STD-461G Section 4.3.4: "When tests are performed in a shielded enclosure and the EUT is in compliance with required limits, the ambient profile need not be recorded in the EMITR."

Guidelines for complying with the ambient electromagnetic level are provided in Section 2.5.3.2.1.

#### 2.5.1.5.2 Power Source Impedance

The impedance of power sources providing input power to the EUT should be controlled by the capacitor network shown in Figure 2.5-1 for all measurement procedures of this document unless a given GSFC program identifies a need to use a LISN, or it is otherwise stated in a particular test procedure. This capacitor network simulates a battery dominated power bus typical of GSFC platforms.

For all MIL-STD-461G based test methods specified in this document, the Line Impedance Stabilization Networks (LISNs) will be replaced by this capacitor network.

Additional discussions of power source impedance and LISNs are provided in Section 2.5.3.2.2.

Check the GSFC Technical Standards Program website at <http://standards.gsfc.nasa.gov> or contact the Executive Secretary for the GSFC Technical Standards Program to verify that this is the correct version prior to use.

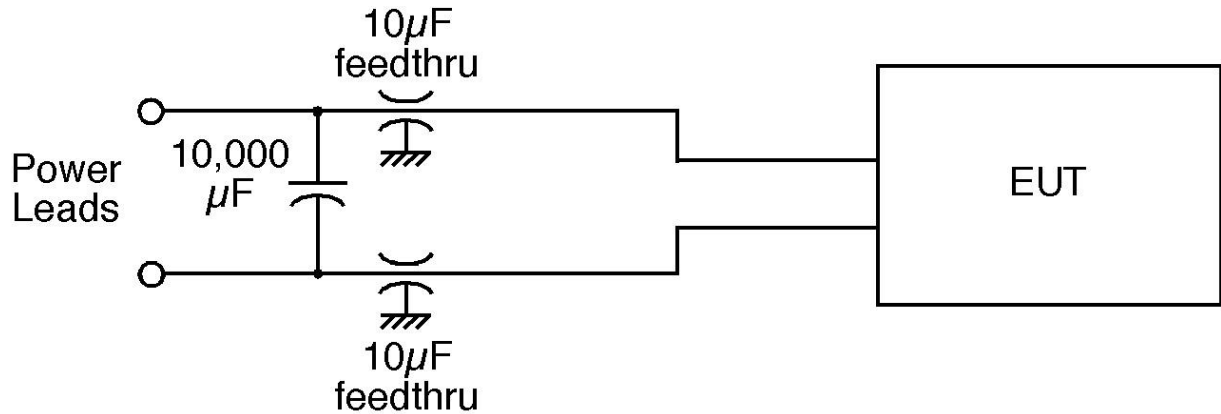

**Figure 2.5-1. Capacitor Network Simulating Battery Dominated Bus Impedance**

#### 2.5.1.5.3 Construction and Arrangement of EUT Cables

The signal cables connecting to the EUT should comply with the requirements defined in MIL-STD-461G Section 4.3.8.6. In particular:

- Electrical cable assemblies must simulate actual installation and usage.
- Cables should be checked against installation requirements to verify proper construction techniques such as use of twisted pairs, shielding, and shield terminations.
- Individual leads should be grouped into cables in the same manner as in the actual installation.

Additional discussion of construction and arrangement of EUT cables is provided in Section 2.5.3.2.3.

#### 2.5.1.5.4 Susceptibility Testing

Susceptibility testing in MIL-STD-461G Section 4.3.10.4 addresses the following topics:

- Frequency scanning (MIL-STD-461G Section 4.3.10.4.1)
- Modulation of susceptibility signals (MIL-STD-461G Section 4.3.10.4.2)
- Thresholds of susceptibility (MIL-STD-461G Section 4.3.10.4.3)

Each of these topics will be discussed in turn below.

##### 2.5.1.5.4.1 Frequency Scanning (MIL-STD-461G Section 4.3.10.4.1)

For swept frequency susceptibility testing, frequency scan rates and frequency step sizes of signal sources should not exceed the values listed in Table 2.5-1. This table replaces MIL-STD-461G Table III. All of the updates are in the last row as noted below.

The upper frequency for susceptibility scans is limited to 18 GHz instead of 40 GHz. The scan from 18 – 40 GHz requires considerably more test time with little added benefit in most cases. Scanning from 18 to 40 GHz is only required if specified in the procurement specification, and it should be specified only if there are specific transmitters operating in that frequency range that pose a concern.

In the 1 GHz to 18 GHz frequency range, the maximum scan rate and maximum step size are increased by a factor of 4 over the values in MIL-STD-461G Table III. Scans in this frequency range take a significant amount of test time; the values in Table 2.5-1 will decrease test time while still providing sufficient frequency resolution to address susceptibility concerns in this frequency range.

**Table 2.5-1. Susceptibility Scanning (Replacement for MIL-STD-461G Table III)**

Frequency Range	Analog Scans Maximum Scan Rates	Stepped Scans Maximum Step Size
30 Hz - 1 MHz	0.0333 $f_0$ /sec	0.05 $f_0$
1 MHz – 30 MHz	0.00667 $f_0$ /sec	0.01 $f_0$
30 MHz - 1 GHz	0.00333 $f_0$ /sec	0.005 $f_0$
1 GHz - 18 GHz	0.00667 $f_0$ /sec	0.01 $f_0$

Check the GSFC Technical Standards Program website at <http://standards.gsfc.nasa.gov> or contact the Executive Secretary for the GSFC Technical Standards Program to verify that this is the correct version prior to use.

#### 2.5.1.5.4.2 Thresholds of Susceptibility (MIL-STD-461G Section 4.3.10.4.3)

Should an EUT fail to meet its susceptibility requirements at the full test level, the threshold(s) of susceptibility should be determined in accordance with MIL-STD-461G procedures.

Should the supplier propose to deliver the EUT as prototype flight equipment without further modification and re-test, sufficient test data must be gathered to support the processing of a waiver using the program's established process. Unless deemed different by the procuring agency (see MIL-STD-461G, Section 4.3.9.3), the following information must be provided:

- Onset of susceptibility, defined as degradation in one or more EUT performance parameters beyond product specification limits or levels.
- EUT transition from soft upset (EUT returns to normal operation upon removal of the immunity stimulus) to hard upset (operator intervention required to reset to normal operation after removal of immunity stimulus), should it occur at or below the full required susceptibility test level.
- Description of degradation of performance with full test level applied.

MIL-STD-461G specifies thresholds of susceptibility in terms of signal amplitude. It may also be desirable to determine the threshold of susceptibility to signal modulation as follows:

- When a susceptibility condition is detected, reduce the modulation duty cycle until the EUT recovers.
- Reduce the modulation duty cycle by an additional 10% or by half, whichever is less.
- Gradually increase the modulation duty cycle until the susceptibility condition reoccurs. The resulting level is the threshold of susceptibility.
- Record this modulation duty cycle, frequency range of occurrence, frequency and level of greatest susceptibility, and other test parameters, as applicable.

If there is susceptibility found at a frequency where a known modulation is used by a specific transmitter, the threshold(s) of susceptibility should also be determined as described above using that modulation scheme at those frequencies of interest. If the EUT is not designed to detect phase modulation, phase modulation may be simulated using a continuous wave (CW) signal, i.e. no modulation.

### 2.5.1.5.5 General Test Setup

The general setup for the EMI tests in this document is shown in Figure 2.5-2. Note that the figure is a modified version of MIL-STD-461G Figure 2, showing the LISNs replaced by the capacitor network specified in Section 2.5.1.5.2.

The general setup for a free standing EUT in a shielded enclosure is shown in Figure 2.5-3. Note that the figure is a modified version of MIL-STD-461G Figure 4 showing the LISNs replaced by the capacitor network specified in Section 2.5.1.5.2.

In both cases, the signal cables should be maintained at a height of 5 cm for their entire run to the access panel, and the power leads should be maintained at a height of 5 cm between the EUT and the capacitor network. The power leads between the capacitor network and the access panel should be routed immediately over the ground plane with no standoffs.

Further discussion is provided in section 2.5.3.2.3.

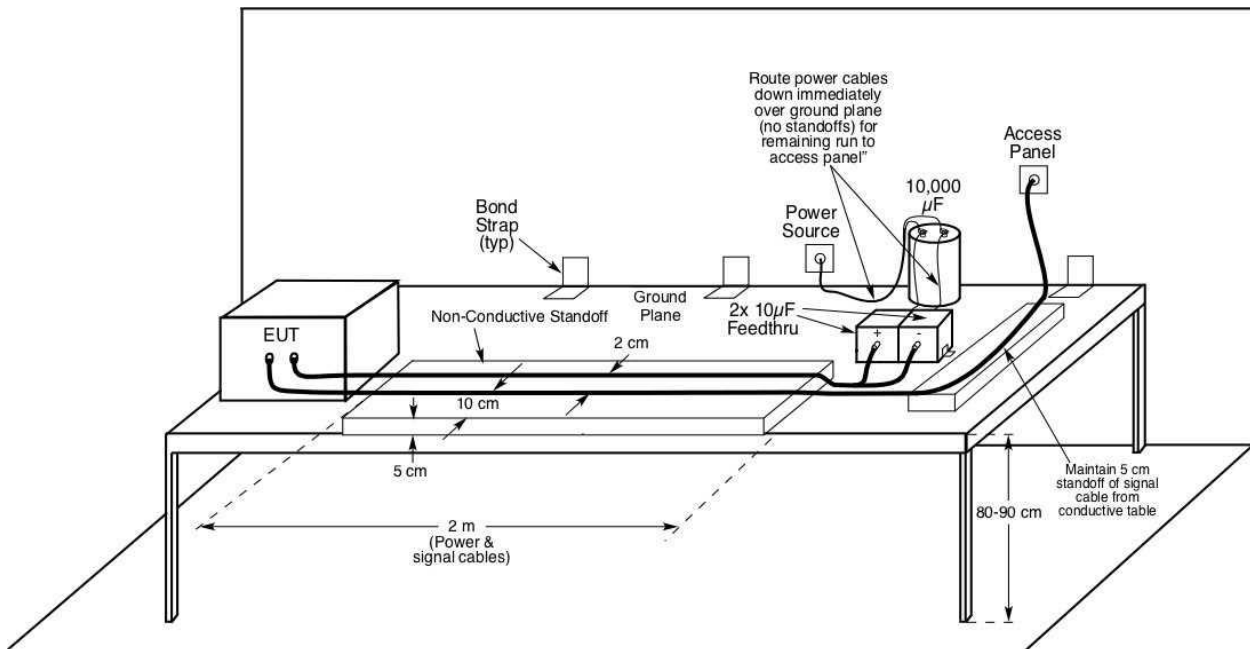
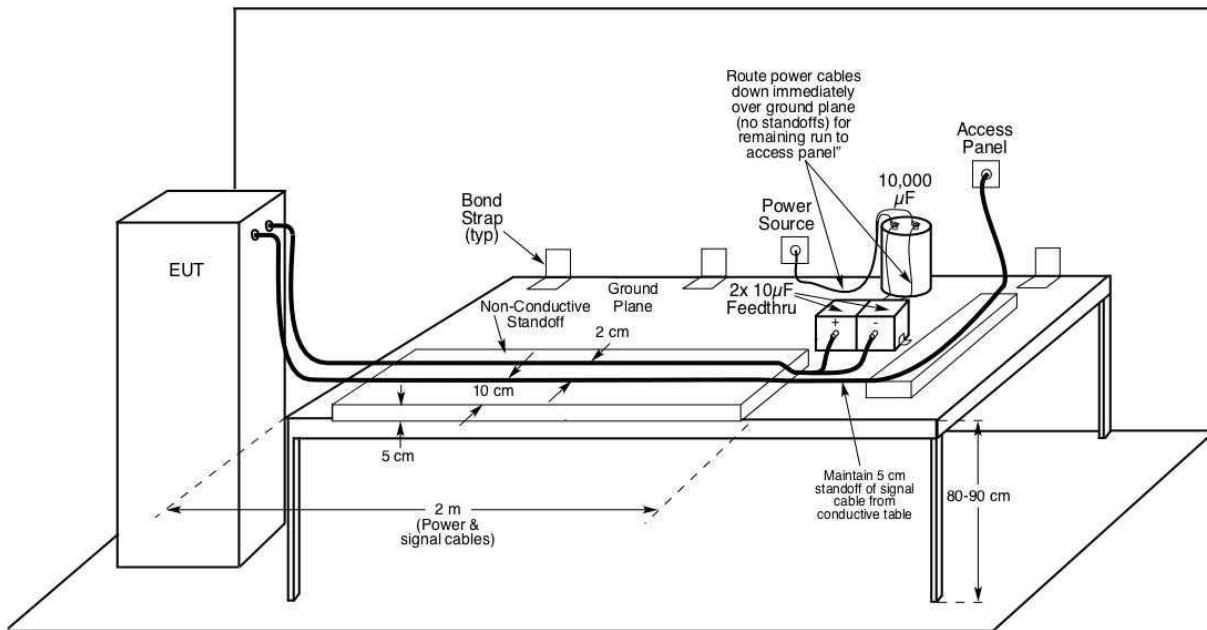

Figure 2.5-2. General Test Setup Diagram (Modified MIL-STD-461G Figure 2)

Check the GSFC Technical Standards Program website at <http://standards.gsfc.nasa.gov> or contact the Executive Secretary for the GSFC Technical Standards Program to verify that this is the correct version prior to use.



**Figure 2.5-3. General test setup for free standing EUT in shielded enclosure**

**(Modified MIL-STD-461G Figure 4)**

#### 2.5.1.6 Documentation Guidelines

It is strongly recommended that each project create a dedicated EMCCP, either as a stand-alone document or as part of another project document. In addition, an EMITP and EMI EMITR must be created for each EUT. The contents of each of these documents will be defined in the following subsections.

##### 2.5.1.6.1 EMC Control Plan (EMCCP)

The EMCCP should provide the following:

- 1) Requirements with appropriate tailoring and documentation references (e.g. GEVS, MIL-STD-461G, etc.)
- 2) Management areas, including:
  - a. Specific organizational responsibilities, lines of authority and control, and program planning, including milestones and schedules.
  - b. Role in program of Government Furnished Equipment (GFE) and subcontractor items.
  - c. Description of the equipment or subsystem, its function, characteristics, and intended installation.
  - d. Plans and procedures for identifying and resolving potential EMI problems, implementing solutions, and verifying solutions through analysis and testing.
  - e. Point of contact for EMI technical issues.

Check the GSFC Technical Standards Program website at <http://standards.gsfc.nasa.gov> or contact the Executive Secretary for the GSFC Technical Standards Program to verify that this is the correct version prior to use.

- 3) Design techniques, including:
  - a. Spectrum management techniques (antenna locations, patterns, operating frequency ranges, sensitivity levels for receivers, power levels for transmitters, etc.)
  - b. EMI mechanical design, including the following:
    - i. Type of metals, casting, finishes, and hardware employed in the design.
    - ii. Construction techniques, such as isolated compartments; filter mounting, isolation of other parts; treatment of openings (ventilation ports, access hatches, windows, metal faces and control shafts), and attenuation characteristics of Radio Frequency (RF) gaskets used on mating surfaces.
    - iii. Shielding provisions and techniques used for determining shielding effectiveness.
    - iv. Corrosion control procedures.
    - v. Methods of bonding mating surfaces, such as surface preparation and gaskets.
- 4) Electrical wiring design, including cable types or characteristics, cable routing, cable separation, grounding philosophy, and cable shielding types, transmission lines, and termination methods.
- 5) Electrical and electronic circuit design, including the following:
  - a. Filtering techniques, technical reasons for selecting types of filters, and associated filter characteristics, including attenuation and line-to-ground capacitance values of AC and DC power line filters.
  - b. Part location and separation for reducing EMI.
  - c. Location, shielding, and isolation of critical circuits.
- 6) Analysis. The EMCCP will provide analysis results demonstrating how each applicable requirement is going to be met.
- 7) Developmental testing. The EMCCP will include a discussion of testing to be performed during development (such as evaluations of breadboards, prototypes, and engineering models).

### 2.5.1.6.2 EMI Test Procedure (EMITP)

The EMITP describes the measurement procedures that will be used to demonstrate that the EUT complies with its contractual EMI requirements defined in the project EMCCP (based on this document), including how the general test procedures will be applied to the specific equipment or subsystem.

The EMITP should be provided for review by the project EMC engineer(s) and the EMI test facility at least 2 weeks prior to the start of EMI tests in order to verify adequate specification of test requirements and procedures; ensure that all required test equipment is available and to give the test facility adequate time to prepare.

The project should provide the following information to be included in the EMITP (may be in the form of a test plan provided to the EMI test facility at least 6 weeks prior to the scheduled start date of the tests):

- 1) Documentation references (e.g. project EMCCP, GEVS, MIL-STD-461G, etc.).
- 2) A table describing all the tests to be performed, the applicable section within the EMITP (or test plan), the corresponding test procedure from this document or MIL-STD-461G, and any associated tailoring of the limits and/or test methods.
- 3) Description of the EUT, including its function, characteristics, intended installation, and power usage.
- 4) Description of platform's power distribution architecture and definition of capacitor network or LISN to be used for tests.
- 5) Approved exceptions or deviations from contractual test requirements, if any.
- 6) EUT setup. A description and diagram of the EUT test setup for each test should cover the following:
  - a. Physical layout of the cables and EUT (see Figure 2.5-2).
  - b. Cable types, characteristics, and construction details (see Section 2.5.1.5.3 of this document)
  - c. Interface at chamber penetration, e.g. bulkhead feedthrough connectors, stuffing tube, etc.
  - d. Position of the capacitor network/LISN on the ground plane.
  - e. Use of bond straps and loads.
  - f. Test simulation and monitoring equipment.
- 7) EUT operation. A description of the EUT operation should cover the following:
  - a. Modes of operation for each test, including operating frequencies (where applicable), and rationale for selection.
  - b. Control settings on the EUT.
  - c. Control settings on any test stimulation and monitoring equipment and characteristics of input signals.
  - d. Operating frequencies (such as oscillator and clock frequencies) which may be expected to approach limits.
  - e. Performance checks initiated to designate the equipment as meeting minimal working standard requirements.

Check the GSFC Technical Standards Program website at <http://standards.gsfc.nasa.gov> or contact the Executive Secretary for the GSFC Technical Standards Program to verify that this is the correct version prior to use.

- f. Enumeration of circuits, outputs, or displays to be monitored during susceptibility testing, including the specific definition of acceptance criteria for monitoring the functional degradation of performance during exposure to an electromagnetic disturbance.
- g. Description of longest machine cycle or response time of critical circuits; used for defining dwell time for susceptibility tests

The EMI Test Facility will provide the following information for the EMITP:

- 1) Test site description, covering the following:
  - a. Test facility and shielded enclosure or anechoic chamber, including size, characteristics (e.g. shielding effectiveness), and placement of radio frequency (RF) absorbers.
  - b. Description of feedthrough filters, if used, at chamber feedthrough panel
  - c. Ground plane (size and type) and methods of grounding or bonding the EUT to the ground plane to simulate actual equipment installation.
  - d. Implementation of test facility and procedure requirements as specified in Section 2.5.1.5 of this document
- 2) Test instrumentation. Test instrumentation to be used should be described as follows:
  - a. Equipment nomenclature.
  - b. Characteristics of coupling transformers and band-reject filters.
  - c. Antenna factors of specified antennas, transfer impedances of current probes, and LISN impedance(s), if used.
  - d. Description of the operations being directed by software for computer-controlled instrumentation, the verification techniques used to demonstrate proper performance of the software, and the specific versions of the software to be used. In addition, sweep times, correction factors and how are they used, how final data are determined and presented, and an audit trail that provides details on what part of the software controls each function should be described.
  - e. Bandwidth (resolution and video) and scanning speeds of measurement receivers.
  - f. Modulation characteristics and scan rates of the susceptibility test signals.
- 3) Measurements. The following should be described for each test.
  - a. Block diagram depicting test setup, including all pertinent dimensions.
  - b. Step-by-step procedures.
  - c. Test equipment used in performance of the test and the methods of grounding, bonding, or achieving electrical isolation of the measurement instrumentation.
  - d. Selection of measurement frequencies.

Information to be recorded during the test, including frequency and units of recorded information. Sample data sheets, test logs and graphs, including test limits, may be shown.

### 2.5.1.6.3 EMI Test Report (EMITR)

The EMITR provides the data and information necessary to evaluate compliance of the EUT with its EMI control requirements based on the project EMCCP, including the discussion of recommended corrective actions, if needed.

The EMITR should provide the following:

- 1) Documentation references (e.g. project EMCCP, EMITP, GEVS, MIL-STD-461G, etc.).
- 2) Administrative data. The EMITR typically contains an administrative section covering the following:
  - a. Contract number.
  - b. Authentication and certification of performance of the tests by a qualified representative of the procuring activity.
  - c. Disposition of the EUT.
  - d. Description of the EUT, including its function, characteristics, intended installation, actual cable types (characteristics and construction details - see Section 2.5.1.5.3 of this document and Figure 2.5-2), and electrical current usage on each power input line.
  - e. List of tests performed with pass/fail indications.
  - f. Any approved deviations from contractual test procedures or limits previously authorized.
  - g. Identification of Non-Developmental Items (NDI) and Government Furnished Equipment (GFE) that may be part of the EUT.
  - h. Traceability of test equipment calibration.
  - i. A reference to the approved EMITP.
- 3) Detailed results. A separate appendix should be prepared for each test. If deviations from an approved test procedure occurred during the test program, an additional appendix should be provided with the "as run" procedures showing all red-lines and procuring activity concurrence. A separate appendix should be provided for log sheets. Each test appendix should contain the following factual data:
  - a. Test equipment nomenclature, serial numbers, version of software used (if any), and calibration due date.
  - b. Photographs or diagrams of the actual test set up and EUT, with identification.
  - c. Transfer impedance of current probes.
  - d. Antenna factors.
  - e. LISN impedance(s), if used.
  - f. Identification of any suppression devices used to meet the contractual requirements, including schematics, performance data, and drawings.
  - g. Sample calculations, such as conversions of measured levels for comparison against the applicable limit.
  - h. The ambient radiated and conducted electromagnetic emission profile of the test facility, when necessary.

- i. Data, and data presentation, as specified in the “data presentation” sections of the individual test procedures of MIL-STD-461. Emissions data cannot be provided on one single sheet (plot). Provide a minimum frequency resolution of 1% or twice the measurement receiver bandwidth, whichever is less stringent, and a minimum amplitude resolution of 1 dB for each plot. Data files for specified scans should be provided upon request in a standardized electronic format.
  - j. Scan speeds.
  - k. Measurement receiver bandwidths.
  - l. Antenna polarization.
  - m. Power line voltages, frequencies, and power factor.
  - n. Low-noise amplifiers (LNA) compression points.
  - o. Test susceptibilities and deviations from normal performance are not acceptable. However, when susceptibility indications or deviations from normal performance are noted in the EUT operation, a threshold level should be determined where the susceptible condition or deviation is no longer present. These thresholds need to be documented for further assessment.
- 4) Conclusions and recommendations, including results of the tests in brief narrative form, a discussion of any remedial actions already initiated, and proposed corrective measures required (if necessary) to assure compliance of the equipment or subsystem with the contractual EMI requirements.

#### 2.5.1.6.4 Waiver Requests

Each non-compliance to project level EMC requirements must be brought to the project to be assessed for corrective actions needed to eliminate the non-compliance and for potential impacts to the program. If the technical impacts to the platform are determined to be acceptable, the non-compliance must be submitted as a waiver request against the appropriate project level EMC requirements documents. If the board determines that the risk of the non-compliance is acceptable to the program and that the EUT does not require corrective action, then the waiver request will be granted.

Each waiver request should contain:

- 1) Documentation references (e.g. project EMCCP, EMITP, EMITR, GEVS, MIL-STD-461G, etc.).
- 2) Identification of specific requirement(s) affected.
- 3) Detailed technical description of non-compliance, including:
  - a. Identification of the source
  - b. Detailed description of potential approach to fix or mitigate the non-compliance.
- 4) Assessment of the cost, schedule impact and any other impacts to the program (e.g., mass and space allocations) due to implementing, or not implementing, the fix.

**Table 2.5-2. EMI Requirements Summary**

Test Description	MIL-STD-461G Designator	GEVS Tailoring	
		Limit(s)	Test Method
Conducted Emissions, Power Leads, 30 Hz to 150 kHz	CE101	tailored	DM
Conducted Emissions, Power Leads, 150 kHz to 50 MHz	CE102	tailored	CE03 (DM) (MIL-STD-462 Test Method)
Conducted Emissions, Common Mode, Power and Signal Lines	no equivalent	new	new
Conducted Emissions, Turn-on Transients	no equivalent	new	new
Conducted Emissions, Antenna Terminal	CE106	tailored	no change
Conducted Susceptibility, Power Leads	CS101	tailored	alternate method available
Conducted Susceptibility, Antenna Port, Intermodulation	CS103	tailored	no change
Conducted Susceptibility, Antenna Port, Rejection of Undesired Signals	CS104	tailored	no change
Conducted Susceptibility, Antenna Port, Cross-Modulation	CS105	not applied	not applied
Conducted Susceptibility, Transients, Power Leads	N/A	CS06	CS06 (MIL-STD-462 Test Method)
Conducted Susceptibility, Structure Current	CS109	not applied	not applied
Conducted Susceptibility, Bulk Cable Injection, 10 kHz to 200 MHz	CS114	tailored	no change
Conducted Susceptibility, Bulk Cable Injection, Impulse Excitation	CS115	no change	no change
Conducted Susceptibility, Damped Sinusoidal Transients	CS116	applied on case-by-case basis	applied on case-by-case basis
Conducted Susceptibility, Lightning Induced Transients	CS117	applied on case-by-case basis	applied on case-by-case basis
Personnel Borne Electrostatic Discharge	CS118	applied on case-by-case basis	applied on case-by-case basis
Radiated Emissions, Magnetic Field	RE101	tailored	alternate method available (RE04) (MIL-STD-462 Test Method)
Radiated Emissions, Electric Field	RE102	tailored	alternate methods available
Radiated Emissions, Antenna Spurious and Harmonic Outputs	RE103	not applied	not applied
Radiated Susceptibility, Magnetic Field	RS101	tailored	no change
Radiated Susceptibility, Electric Field	RS103	tailored	tailored
Radiated Susceptibility, Transient Electromagnetic Field	RS105	not applied	not applied

Check the GSFC Technical Standards Program website at <http://standards.gsfc.nasa.gov> or contact the Executive Secretary for the GSFC Technical Standards Program to verify that this is the correct version prior to use.

## 2.5.2. Detailed Requirements

The EMI requirements are divided into four categories: Conducted Emissions (CE), Conducted Susceptibility (CS), Radiated Emissions (RE), and Radiated Susceptibility (RS). Table 2.5-2 provides the summary list of specific requirements defined in this document. For each requirement, the equivalent MIL-STD-461G designator is identified, and GEVS tailoring of the limit(s) and/or test method is indicated.

The details of the requirements are provided in the following subsections.

### 2.5.2.1 Conducted Emissions Requirements

Conducted emission requirements on power leads, signal leads, and antenna terminals should be applied to payload and spacecraft hardware as defined in the following subsections.

#### 2.5.2.1.1 Conducted Emissions, Power Leads, Differential Mode

Applicability: This requirement is applicable to equipment power leads, including returns, that operate from a spacecraft primary power bus that may be shared with other loads.

Purpose: The purpose of this requirement is to limit the conducted emissions from the EUT in order to control load-induced effects on power quality.

Test method: From 30 Hz to 150 kHz, the basic MIL-STD-461G CE101 test method will apply with the send and return wires run through the current probe for a differential mode (DM) measurement as shown in Figure 2.5-4 and Figure 2.5-5. The current probe must be placed within 5 cm of the capacitor network as shown in the figures.

From 150 kHz to 50 MHz, the test method shown in Figure 2.5-4 and Figure 2.5-5 shall apply using a current probe that is suited to the higher frequency range. This is effectively the basic MIL-STD-462 CE03 test method with the send and return wires run through the current probe for a DM measurement.

Limit: The DM current emissions limits are shown in Figure 2.5-6. Because the (DM) test method measures twice the true DM current (6 dB above the true value), the measured limit must be set 6 dB above the true maximum DM current.

The default limit (blue curve) is for loads with a steady state current of 1 Amp DC or less. The low frequency plateau shifts upward for higher currents by adding a factor of  $20 \cdot \log(\text{load current in Amperes})$ . Example curves corresponding to load currents of 3 A rms and 10 A rms are shown.

Further discussion of the limit and test method are provided in section 2.5.3.3.1.

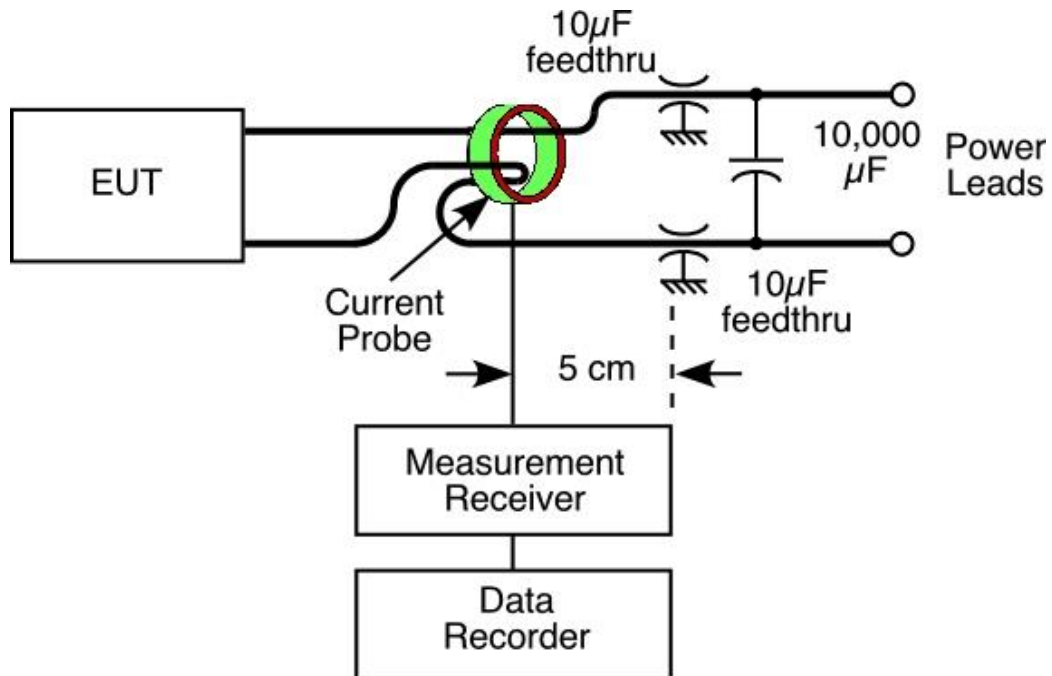

Figure 2.5-4. Conducted Emissions Test Setup (Schematic) - Differential Mode

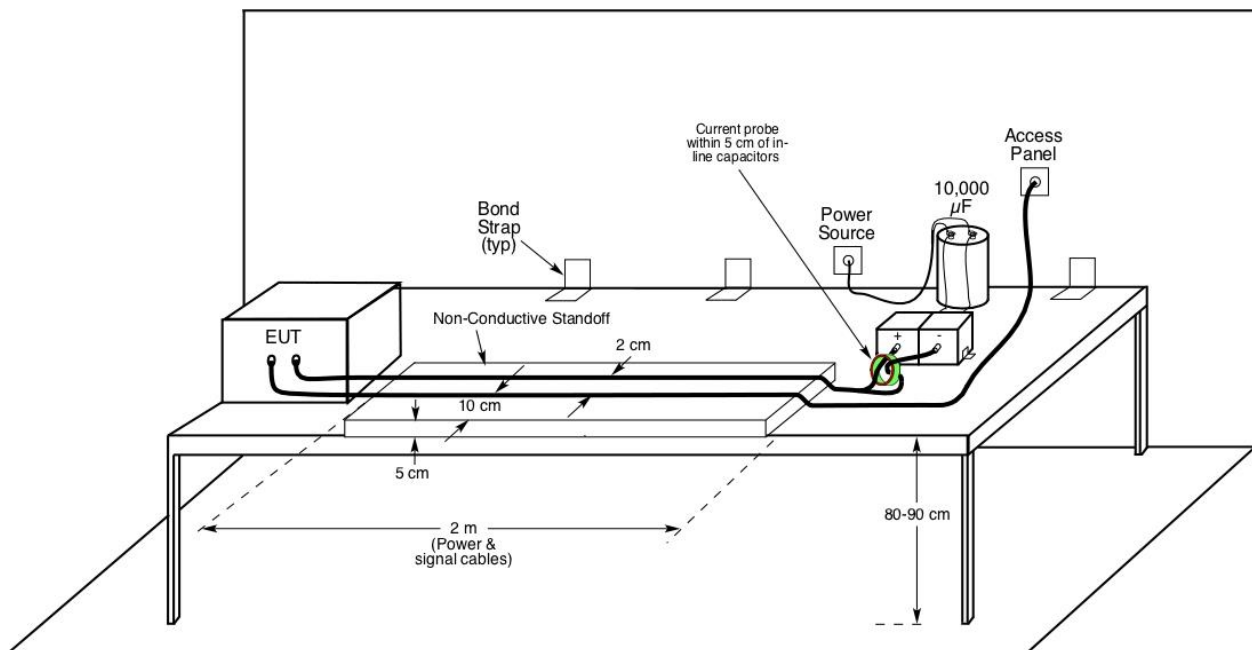

Figure 2.5-5. Conducted Emissions Test Setup (Physical Layout) – Differential Mode

Check the GSFC Technical Standards Program website at <http://standards.gsfc.nasa.gov> or contact the Executive Secretary for the GSFC Technical Standards Program to verify that this is the correct version prior to use.

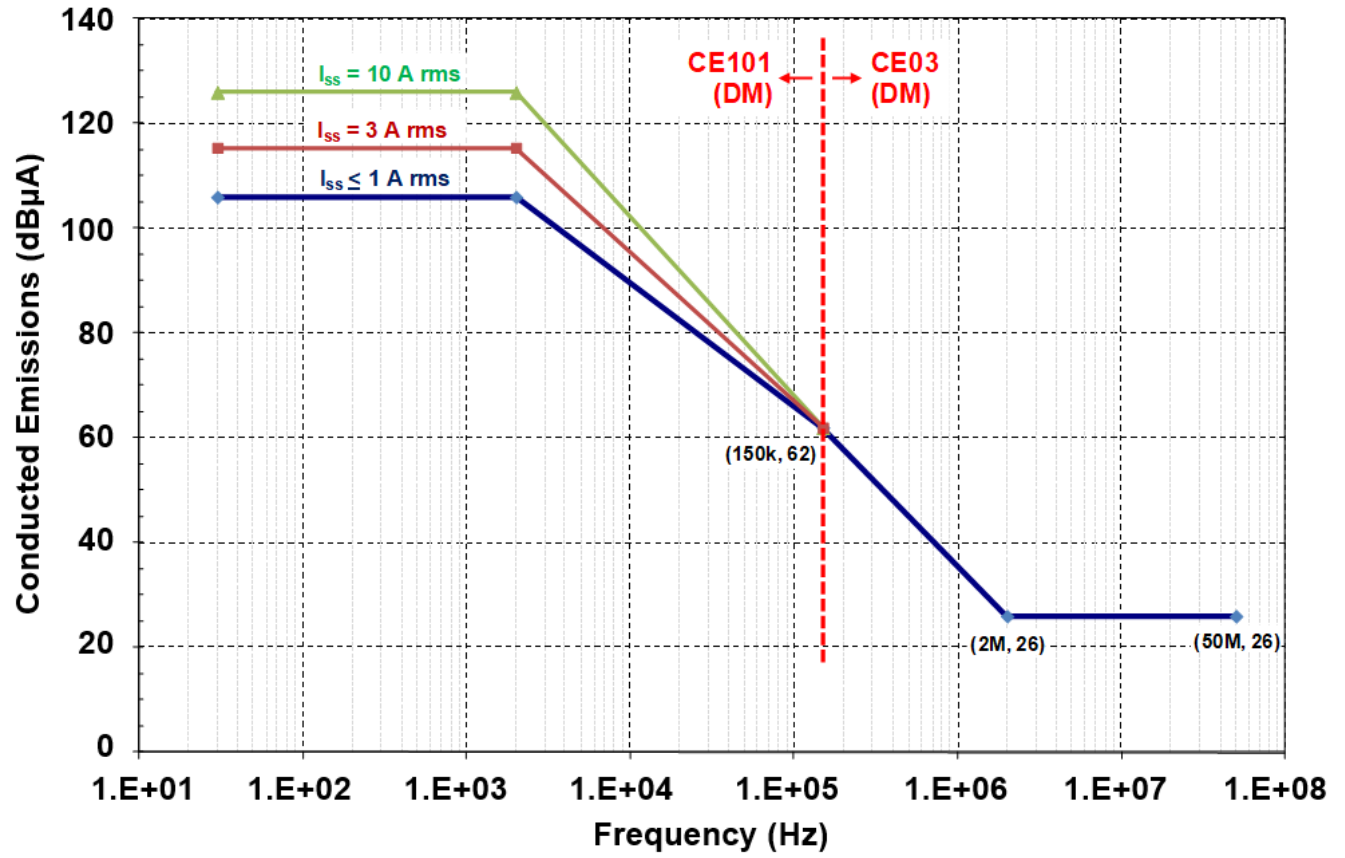

Figure 2.5-6. Conducted Emissions Differential Mode Limits

Check the GSFC Technical Standards Program website at <http://standards.gsfc.nasa.gov> or contact the Executive Secretary for the GSFC Technical Standards Program to verify that this is the correct version prior to use.

### 2.5.2.1.2 Conducted Emissions, Common Mode, Power and Signal Lines

**Applicability:** This requirement is applicable to power and signal cables.

**Purpose:** The purpose of this requirement is to limit the common mode conducted emissions (CMCE) from bulk cables in order to protect against cable-to-cable crosstalk. This requirement is intended to be a companion to the Common Mode Conducted Susceptibility requirement (CS114).

**Limit:** There is no MIL-STD-461G equivalent for this requirement.

The default limit is 50 dB $\mu$ A from 10 kHz to 200 MHz as shown by the dark blue and red lines in Figure 2.5-7. If the platform's magnetic requirements necessitate control of common mode currents below 10 kHz, it may be desirable to extend the limit down to 30 Hz as shown by the light blue dashed line.

Discussion of this limit and tailoring guidelines are provided in Section 2.5.3.3.2.

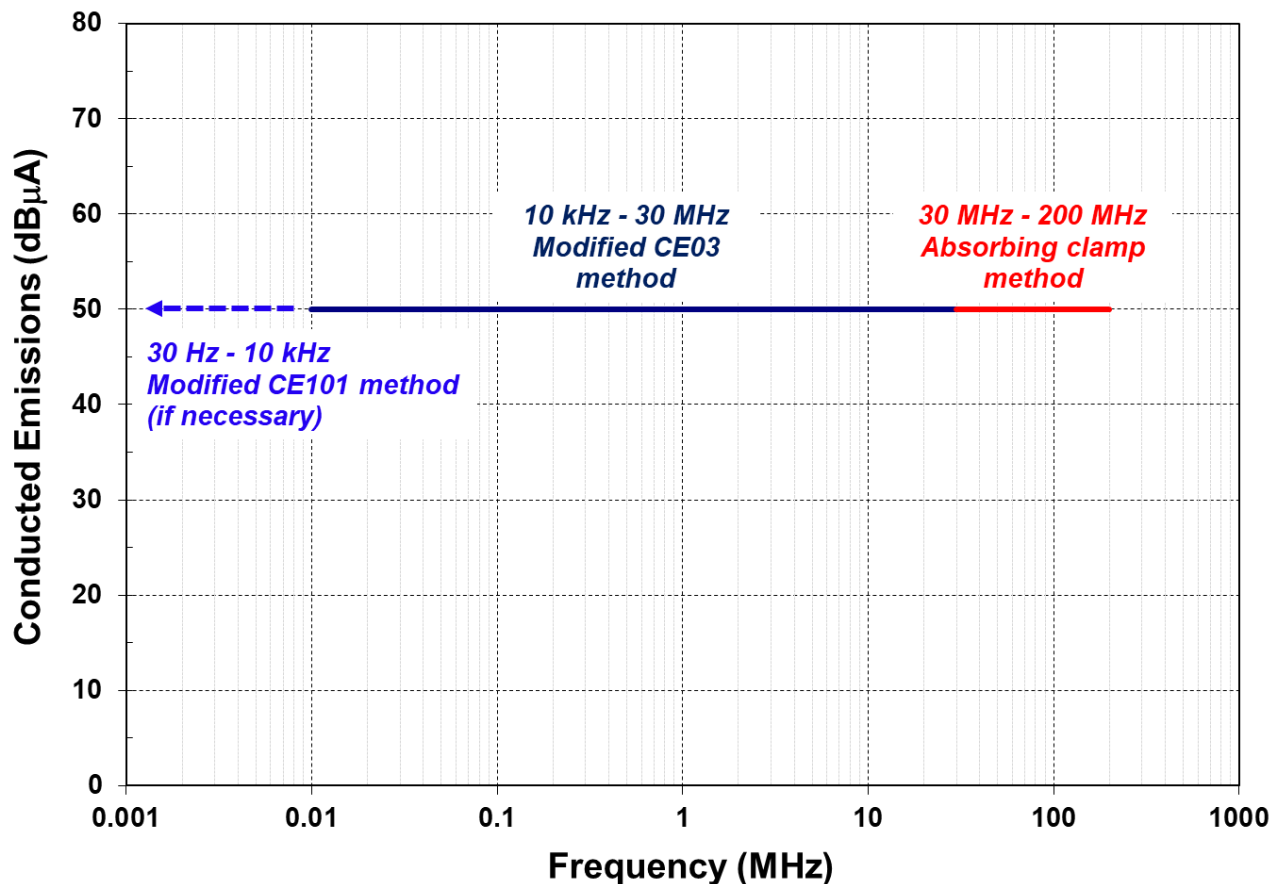

**Figure 2.5-7. Common Mode Conducted Emissions Default Limit**

Check the GSFC Technical Standards Program website at <http://standards.gsfc.nasa.gov> or contact the Executive Secretary for the GSFC Technical Standards Program to verify that this is the correct version prior to use.

Test Method: There is no MIL-STD-461G equivalent for this requirement.

The test method from 30 Hz to 10 kHz (if necessary) is essentially the same as the tailored CE101 test method discussed in section 2.5.2.1.1, except that 1) the upper frequency limit is 10 kHz, and 2) the current probe is placed around each individual bulk cable under test for a common mode measurement as shown in Figure 2.5-8 for power cables and Figure 2.5-9 for signal leads. Because the wavelengths at these frequencies are significantly longer than the cables, the current is uniform along the length and the position of the current probe along the length of the cable is not crucial.

The test method from 10 kHz to 30 MHz is essentially the same as the tailored CE03 test methods discussed in section 2.5.2.1.1, except that 1) the lower frequency limit is 10 kHz, and 2) the current probe is placed around each individual bulk cable under test for a common mode measurement as shown in Figure 2.5-9 or around both power leads as shown in Figure 2.5-8. Also, the measurement is performed only to 30 MHz. In the upper end of this frequency range, the cable will be “electrically long” (i.e. a significant fraction of a wavelength), and the current distribution along the cable will not be constant due to standing waves. As discussed in detail in section 2.5.3.3.2, the peak current will occur at the load end of the cable for power leads and shielded cables. For unshielded cables and cables with unterminated shields, the peak current may occur at different points along the line.

For the test cable configuration, that means that the current probe should be placed as close to the access panel as possible, as shown in Figure 2.5-9, in order to catch the peak level at these frequencies.

For CMCE measurements on power cables, the current probe should be placed adjacent to the capacitor network as shown in Figure 2.5-8 (as it is for the differential mode measurements).

The test method from 30 MHz to 200 MHz is adapted from the alternate RE102 test method below 200 MHz for Bulk Cable Emission (BCE) defined in SL-E-0002, Space Shuttle Specification, Electromagnetic Interference Characteristics, Requirements for Equipment. The basic test setup is shown in Figure 2.5-10 and it uses an absorbing clamp instead of a standard current probe.

As discussed in detail in section 2.5.3.3.2, the absorbing clamp is particularly effective on longer cables, and it is most effective on EUTs with a single cable. In particular, it should be used for the 2-meter primary power cables and the signal cables connecting to the access panel. A typical length for the signal cables is approximately 4 meters, i.e. 2 meters running along the front edge of the ground plane in addition to approximately 2 meters to the access panel.

For cables longer than 4 meters, it may be desirable to extend the lower frequency limit of the absorbing clamp measurements down to 10 MHz.

If CMCE measurements are desired on shorter cables connecting between different portions of the EUT (e.g. a setup that includes multiple electronics boxes with cables connecting between them), the absorbing clamp is less effective and less practical. In many cases, the layout of such cables may not allow sufficient room for the absorbing clamp, and a standard current probe must be used.

As discussed above and in section 2.5.3.3.2, for the typical situation of shielded cables terminated at both ends and equipment enclosures with class R bonds to structure (ground plane), the current probe should be placed at the load end (opposite to the signal source) of a properly terminated shielded cable in order to capture the peak current at all frequencies. If signal sources are connected at both ends of the cable, measurements should be taken at both ends.

For unshielded cables and cables with unterminated shields, the peak current may occur at different points along the line. For such cables, the current should be measured with the current probe located at least every tenth wavelength at the highest frequency of interest. At 30 MHz,  $\lambda/10 = 1$  meter; at 200 MHz,  $\lambda/10 = 15$  cm. For cables up to 1 meter in length, only two positions are required, i.e. at each end of the cable. For cables longer than 1 meter, it should be possible to insert the absorbing clamp to perform the measurement in a single location, which will be more efficient than measurements with the current probe in multiple locations.

A detailed discussion of current distribution along the cable, the absorbing clamp, and this test method is provided in Section 2.5.3.3.2.

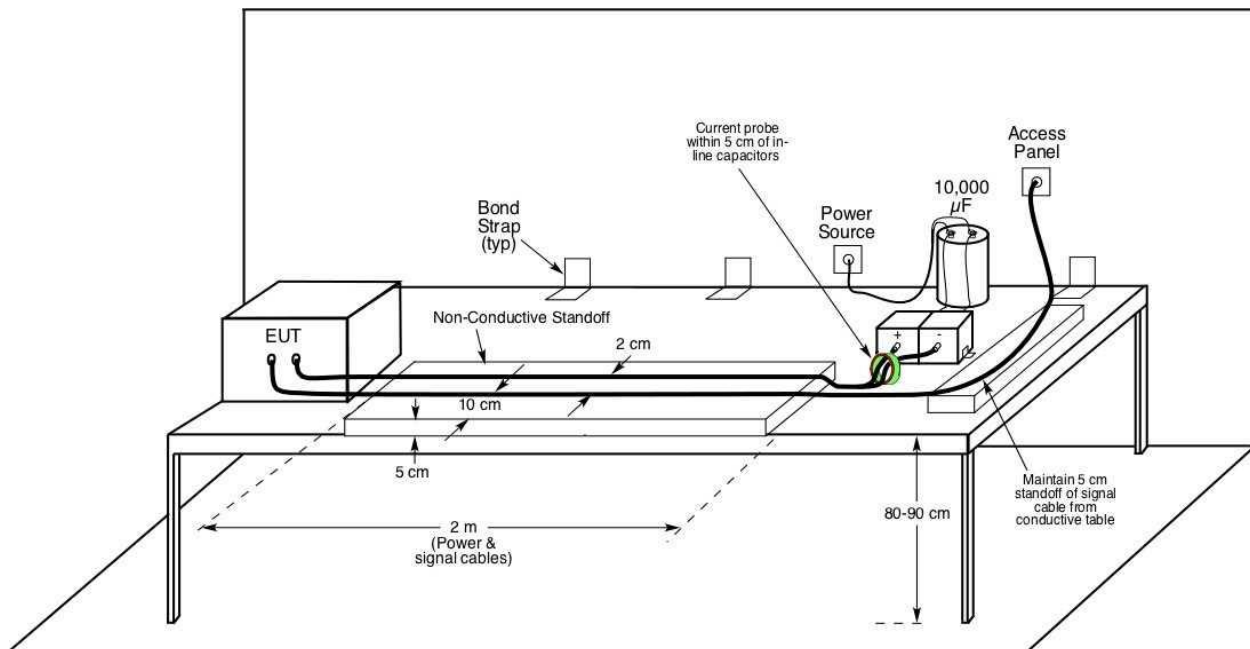

**Figure 2.5-8. CMCE Test Setup, Modified CE101/CE03 Test Methods, Power Leads**

Check the GSFC Technical Standards Program website at <http://standards.gsfc.nasa.gov> or contact the Executive Secretary for the GSFC Technical Standards Program to verify that this is the correct version prior to use.

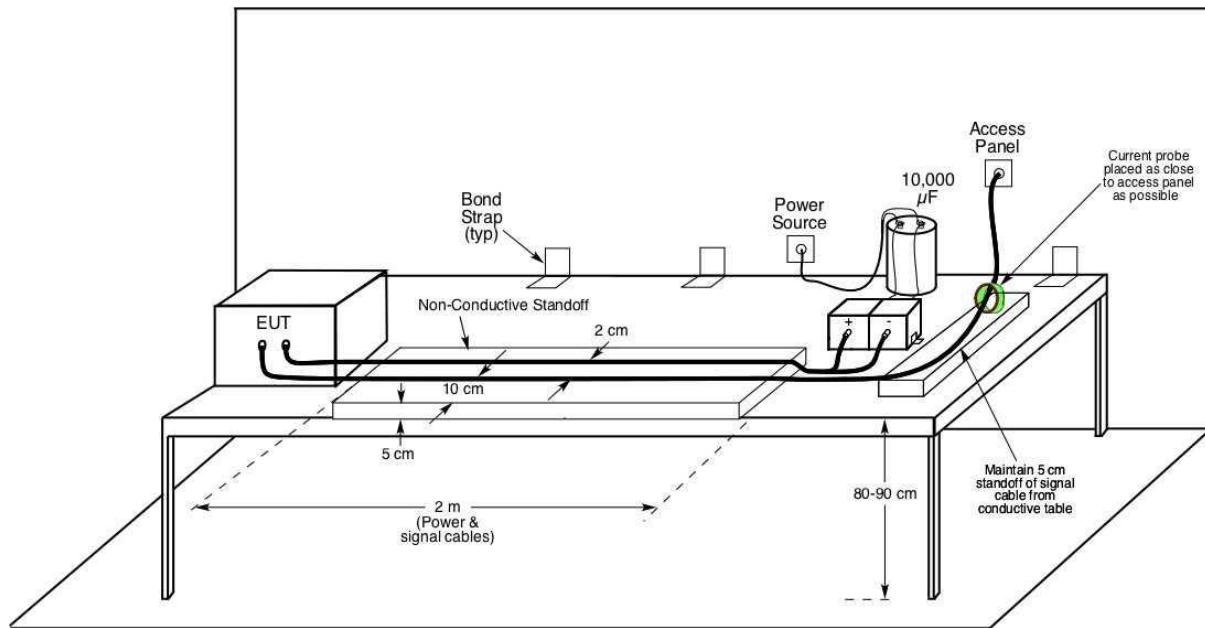

Figure 2.5-9. CMCE Test Setup, Modified CE101/CE03 Test Methods, Signal Cables

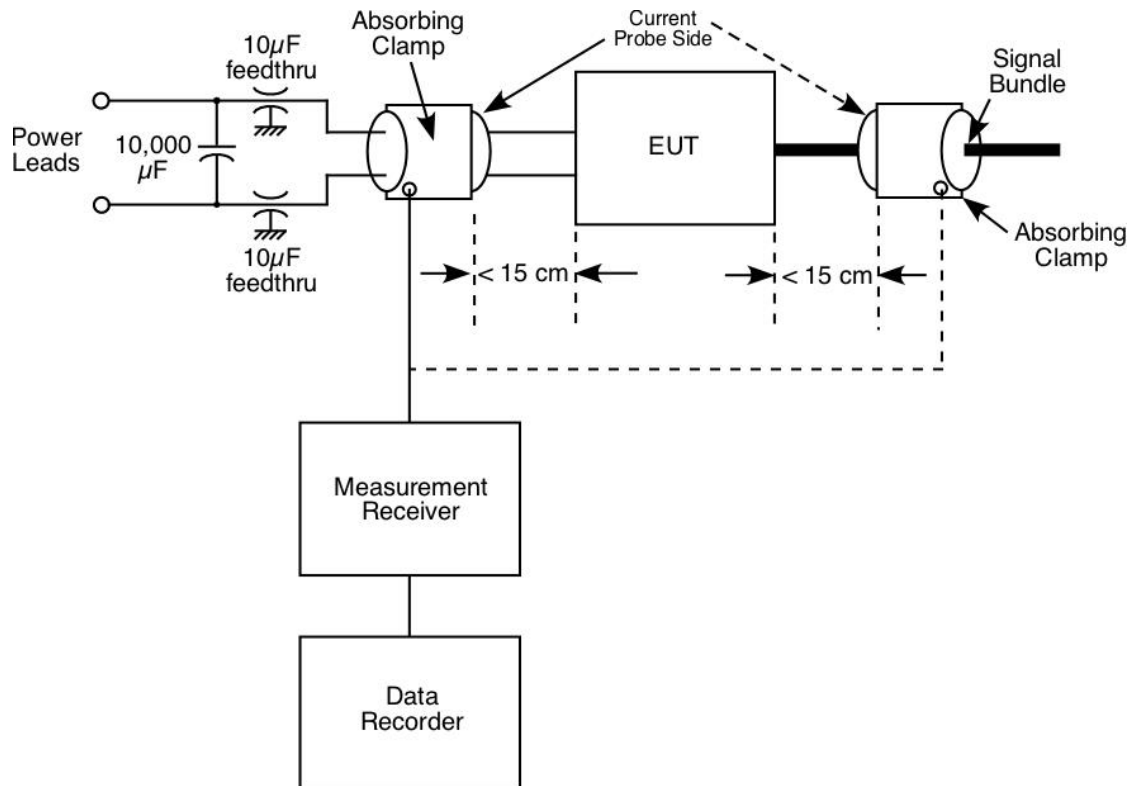

Figure 2.5-10. CMCE Test Setup, Absorbing Clamp Method

Check the GSFC Technical Standards Program website at <http://standards.gsfc.nasa.gov> or contact the Executive Secretary for the GSFC Technical Standards Program to verify that this is the correct version prior to use.

### 2.5.2.1.3 Conducted Emissions, Time Domain, Transients

Applicability: This requirement applies to the following:

- 1) Turn-on transients generated by equipment that is connected to the spacecraft primary power bus through an external relay, solid-state switch or circuit breaker located in the bus power system.
- 2) Operational transients generated by equipment that enables and disables secondary loads (e.g. secondary power converters, motors, reaction wheels, cryocoolers, etc.)

Purpose: The purpose of this requirement is to ensure that equipment inrush current due to turn-on and operational transients will neither adversely affect the power bus nor overstress its circuit protection device (e.g. fuse).

Limit: There is no MIL-STD-461G equivalent for this requirement. The default limit is shown in Figure 2.5-13 and is described as follows:

The peak inrush current caused by turn-on or operational transient should not exceed 1000% of the unit peak operational current for the first 10 microseconds after the start of the transient, should not exceed 300% of the unit peak operational current from 10 microseconds to 20 milliseconds after the start of the transient, and should return to peak operational current within 20 milliseconds of the start of the transient. The requirement should be met when the unit input voltage is the maximum steady-state operational voltage of the unit.

The default limit must be compared against the characteristics of the specific circuit protection device(s) used on the platform and tailored as necessary. Additional discussion is provided in Section 2.5.3.3.3.

It is recommended that the inrush current measurement be repeated at payload and/or spacecraft level as part of each unit's integration procedure.

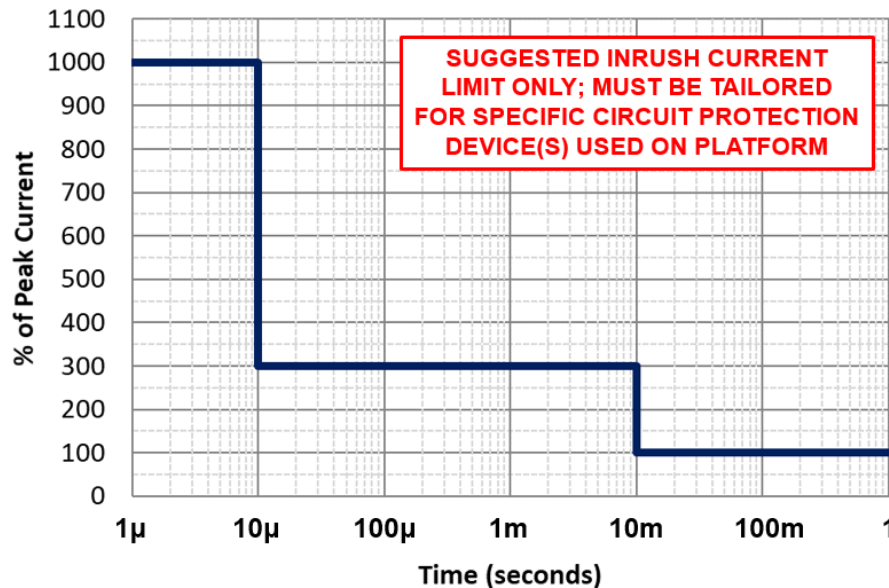

**Figure 2.5-11. Inrush Current Transient Default Limit**

Test Method: There is no MIL-STD-461G equivalent for this requirement.

The basic test setup using a current probe is shown in Figure 2.5-12; an alternate test setup that measures the voltage drop across a series resistor is shown in Figure 2.5-13. It is recommended that the series resistor be placed in series with the return (-) lead in order to minimize the DC common mode potential.

Given that this is a time domain measurement, a current probe must be selected that has a flat transfer impedance at least from 20 Hz to 1 MHz in order to ensure accurate reproductions of waveforms with a resolution of approximately 1 microsecond.

EUT Test Procedure:

- 1) Configure the test equipment as shown in Figure 2.5-12 if using the current probe method or Figure 2.5-13 if using the series resistor method.
- 2) Set up oscilloscope initially as defined in the calibration procedure with the time scale set to 50  $\mu$ s/div for the first sweep.
- 3) Energize switch and record waveform of turn-on transient. If entire waveform is not recorded on-screen, due to either amplitude or duration, readjust vertical sensitivity and/or horizontal time base as necessary to yield on-screen trace.
- 4) Perform additional sweeps with the oscilloscope time scale set to 500  $\mu$ s/div and 2 ms/div.
- 5) Repeat measurement for all operational transients in addition to the turn-on transient. When making multiple inrush measurements, ensure that test sample power supply filters have time to adequately discharge between measurements.

Data presentation:

Data should be presented in the form of a print out or screen dump of actual oscilloscope display, both for calibration and actual test waveforms. Entire waveform should be displayed from one division before turn-on event to complete return to nominal conditions.

Additional procedure details and discussions are provided in Section 2.5.3.3.2.

2.5.2.1.4 Conducted Emissions, Antenna Terminal

Applicability: This requirement is applicable to the antenna terminals of RF transmitters, receivers, and amplifiers.

Purpose: The purpose of this requirement is to ensure that emissions from the EUT do not interfere with other antenna-connected receivers on the platform.

Limit and Test Method: MIL-STD-461G CE106 limits and test method shall apply in frequency bands used by other antenna-connected receivers on the platform. For most GSFC platforms, this will consist of frequencies above 200 MHz (see section 2.5.2.3.2, RE102).

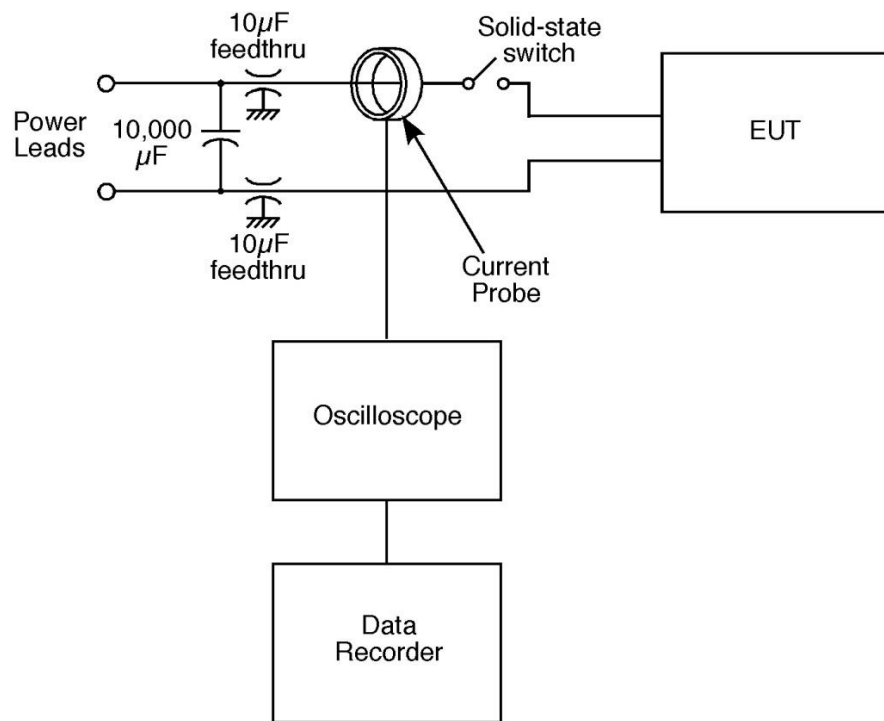

Figure 2.5-12. Inrush Current Emissions Test Setup (Current Probe)

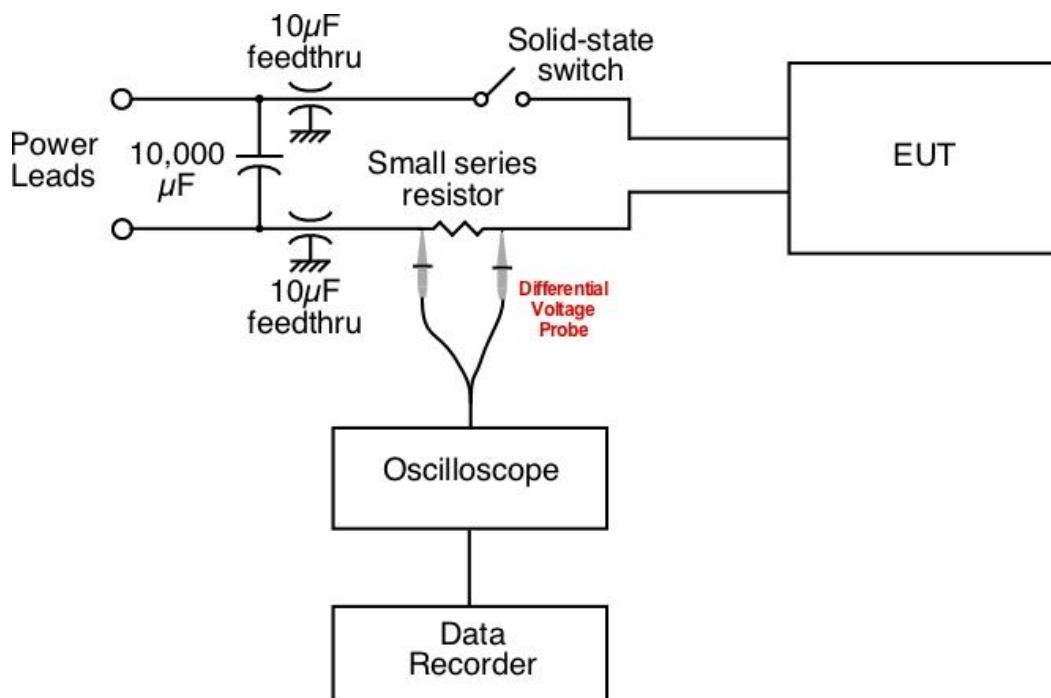

Figure 2.5-13. Inrush Current Emissions Alternate Test Setup (Series Resistor)

### 2.5.2.2 Conducted Susceptibility Requirements

Conducted susceptibility requirements on power leads, signal leads, and antenna terminals shall be applied to payload and spacecraft hardware as defined in the following subsections.

#### 2.5.2.2.1 Conducted Susceptibility, Primary Power Leads

Applicability: This requirement is applicable from 30 Hz to 150 kHz for DC input power leads, not including returns.

Purpose: The purpose of this requirement is to verify the ability of the EUT to withstand voltage ripple on the spacecraft primary power bus.

Limit: The EUT shall not exhibit any malfunction, degradation of performance, or deviation from specified indications, beyond the tolerances indicated in the individual equipment or subsystem specification, when subjected to a test signal with voltage levels as specified in Figure 2.5-14.

If the pre-calibration method is used, the requirement is also met when the power source is adjusted to dissipate the power level shown in Figure 2.5-15 in a 0.5  $\Omega$  load and the EUT is not susceptible.

If the direct current monitor/control method is used, the requirement is also met if 1 Vrms cannot be established, but 4 Arms is injected without malfunction, degradation of performance, or deviation from specified indications, beyond the tolerances indicated in the individual equipment or subsystem specification.

As discussed in section 2.5.3.3.4, the 4 Arms short-circuit current level corresponds to the default power limit in Figure 2.5-15. If a different current limit is preferred, it must be approved by the project EMC engineer(s) and documented in the project EMCCP.

Test method: The general setup shown in Figure 2.5-16 may be applied. This setup is largely based on the MIL-STD-461G CS101 test method.

An alternate test method is shown in Figure 2.5-17. Instead of performing the pre-calibration to the specified power limit, the injected current is directly monitored and controlled to a not-to-exceed short-circuit current level of 4 A.

NOTE: Whichever test method is used, the potential across the EUT must be monitored with a differential voltage probe as shown in Figures 2.5-14 and 2.5-15. A standard probe will connect the EUT's return lead to the oscilloscope's chassis, providing an undesirable additional grounding path that may adversely affect the measurement.

**CAUTION!!!** When using any variation of the standard CS101 test method, the power amplifier driving the coupling transformer (shown in MIL-STD-461G Figure CS101-4) **MUST** be powered up and allowed to stabilize prior to applying power to the EUT. Failure to do so has been demonstrated to cause instability and damage to EUTs.

Further discussion of the CS101 limits, test methods, and tailoring guidelines are provided in Section 2.5.3.3.2. The requirement for conducted susceptibility on power leads from 150 kHz to 200 MHz is defined in section 2.5.2.2.4.2 (CS114 test method).

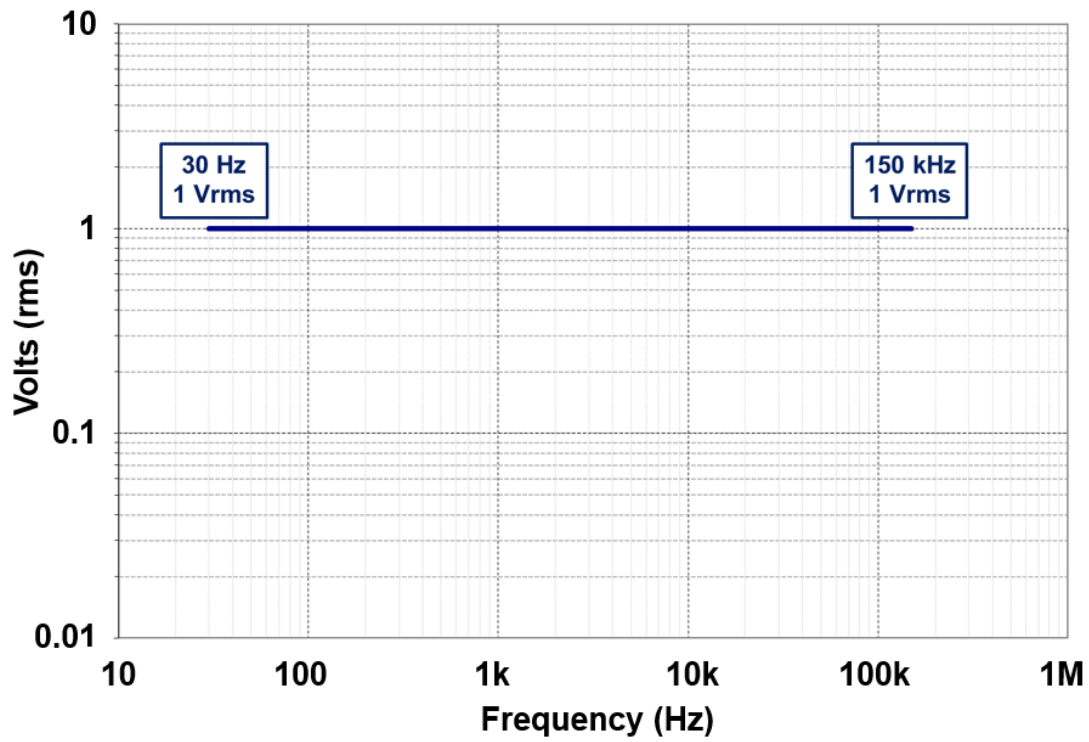

Figure 2.5-14. Conducted Susceptibility Voltage Limit, (30 Hz to 150 kHz)

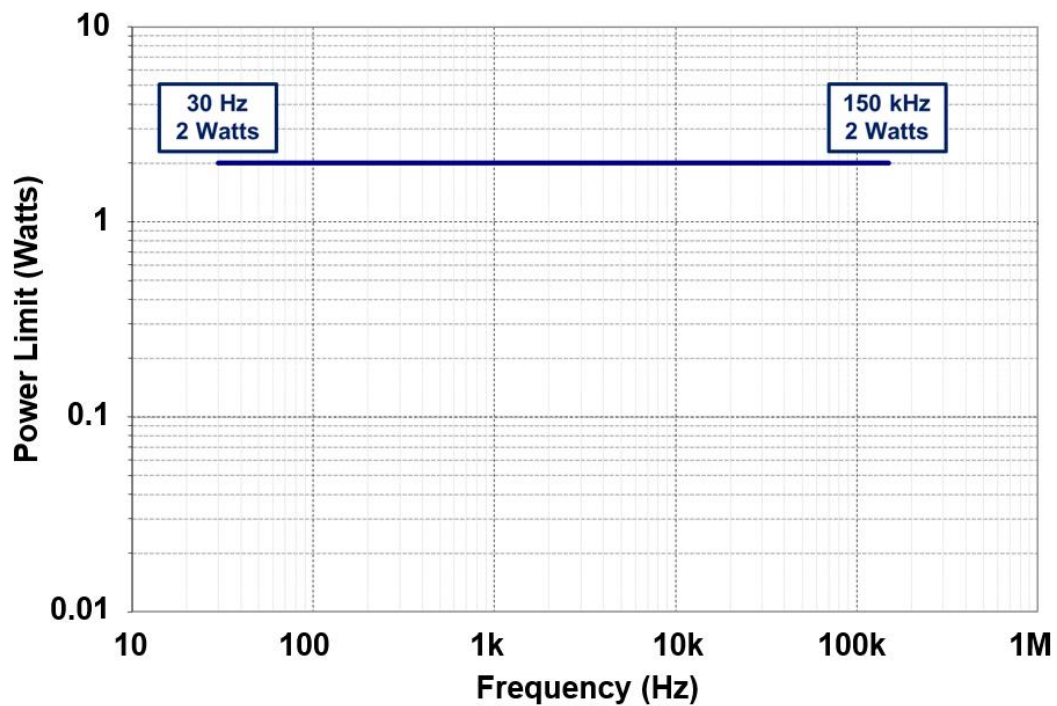

Figure 2.5-15. Conducted Susceptibility Power Limit (30 Hz to 150 kHz)

Check the GSFC Technical Standards Program website at <http://standards.gsfc.nasa.gov> or contact the Executive Secretary for the GSFC Technical Standards Program to verify that this is the correct version prior to use.

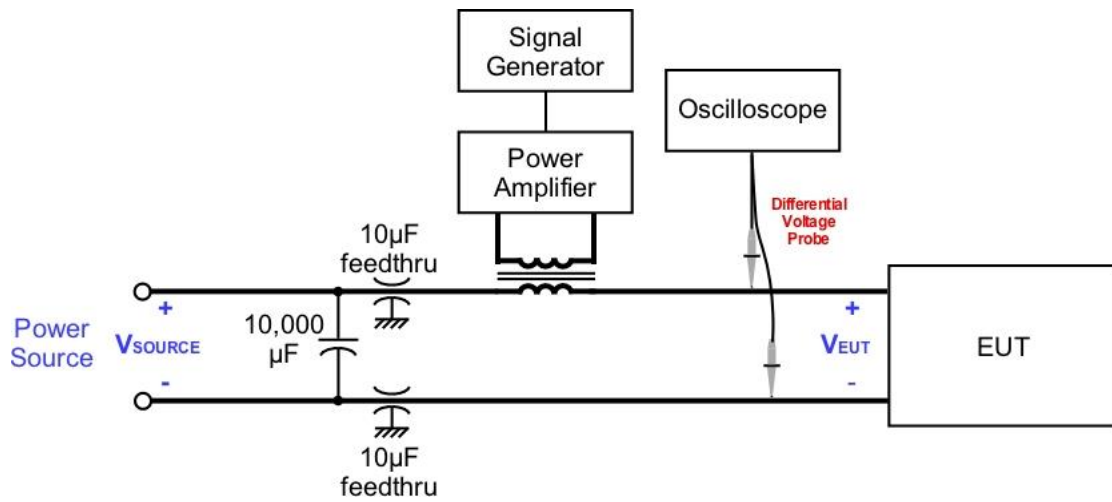

Figure 2.5-16. General CS101 Test Setup

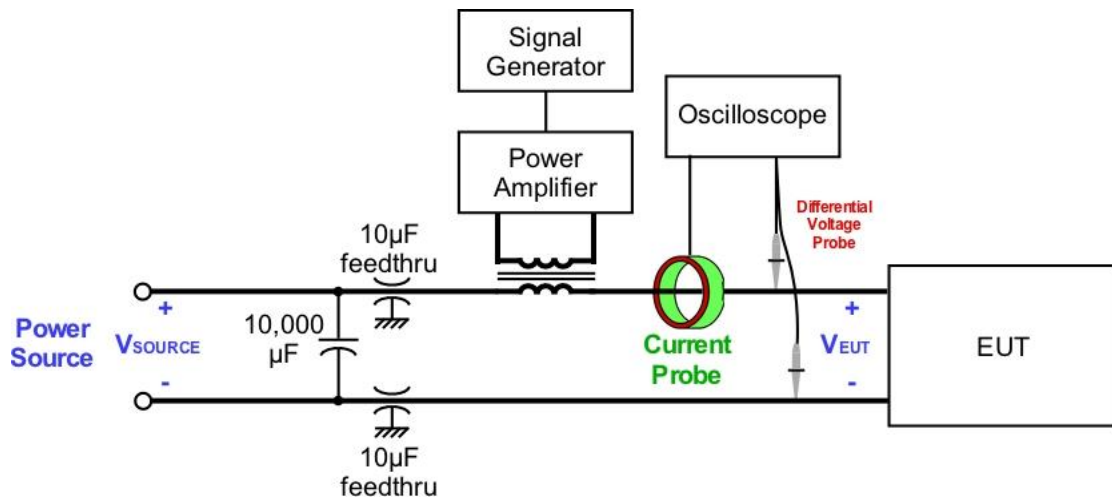

Figure 2.5-17. Alternate CS101 Test Method With Direct Current Monitoring

#### 2.5.2.2.2 Conducted Susceptibility, Antenna Terminals

Applicability: These requirements are applicable to antenna terminals of radio frequency (RF) receivers as specified in the individual procurement specification.

Purpose: The purpose of these requirements is to verify that the EUT rejects out-of-band RF signals from other antenna-connected transmitters on the platform.

Limit and Test Methods: MIL-STD-461G CS103 (intermodulation) and CS104 (rejection of undesired signals) limits and test methods shall be applied. Where appropriate, testing may be limited to specific frequency bands used by antenna-connected systems on the spacecraft and launch vehicle.

Additional guidelines for defining mission-specific limits and test methods are provided on the GSFC EMC Working Group SPACES site:

<https://spaces.gsfc.nasa.gov/display/EMCWG/Home>.

#### 2.5.2.2.3 Conducted Susceptibility, Transients, Power Leads

Applicability: This requirement is applicable to equipment operating from spacecraft primary power. It applies only to equipment operating from buses where equipment may be switched on and off the bus at full potential. This requirement does not apply to platforms where all loads are hardwired to the bus without a switch and are first energized as the bus is energized.

Purpose: The purpose of this requirement is to verify the ability of the EUT to withstand transients coupled onto its input power leads. Such transients include:

- Negative transients, which are generally due to equipment being switched onto the bus, in which the bus is pulled instantaneously to near zero-volt potential and returns to nominal potential after a recovery time. Such transients are common to all platforms.
- Positive transients, which are generally associated with a back electromotive force (emf) from a rapidly changing inductive load (e.g. motor).

Limit: The limit is shown in Figure 2.5-18. This is the negative version of the CS06 waveform defined by MIL-STD-461C. The pulse shall be applied at a minimum of once per second for one minute.

For all platforms, the negative transient shall be applied. For platforms that include rapidly changing inductive loads that are expected to generate significant back emf onto the bus, the positive transient shall be applied as well.

Test Method: The MIL-STD-462 CS06 test method may be applied as shown in Figure 2.5-19 and Figure 2.5-20. The series injection setup is recommended for most applications; for higher power loads, the parallel injection setup may be used. Note that if the parallel method is used, the standard source impedance capacitors should be removed in order to avoid loading down the CS06 generator.

Section 2.5.3.3.3 provides further discussion of the CS06 limit and test method.

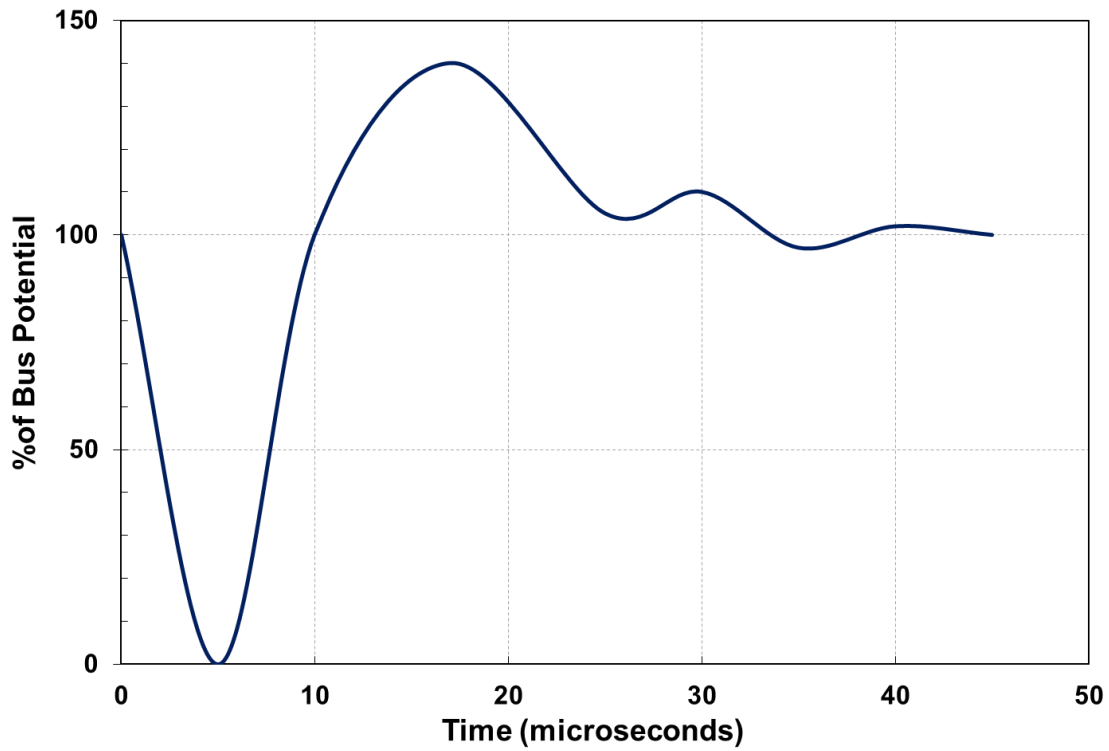

Figure 2.5-18. Conducted Susceptibility Transient Waveform

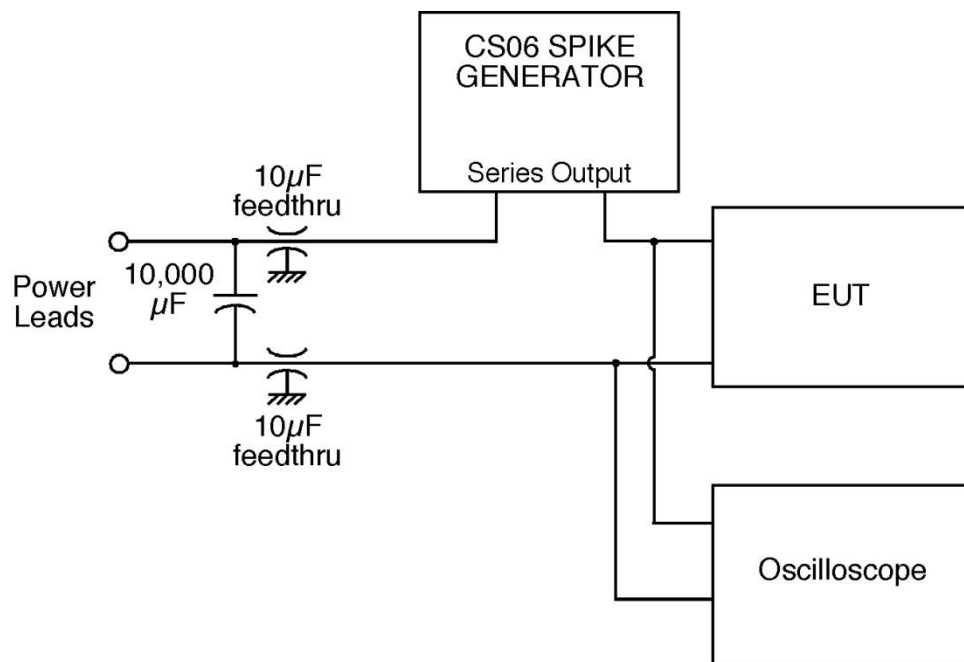
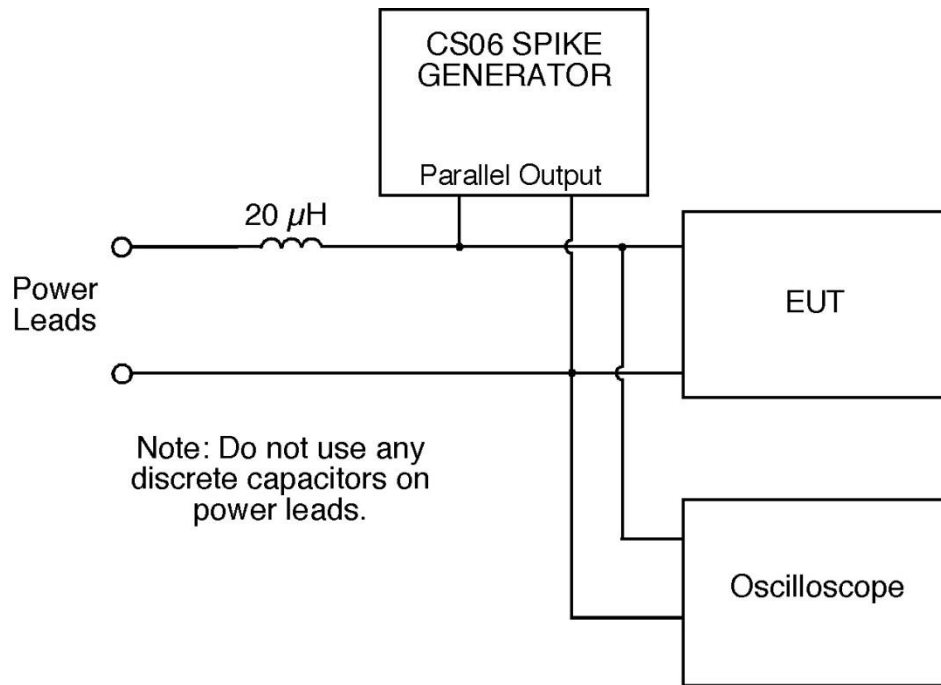

Figure 2.5-19. Conducted Transient Susceptibility Test Setup – Series Injection



**Figure 2.5-20. Conducted Transient Susceptibility Test Setup – Parallel Injection**

#### 2.5.2.2.4 Conducted Susceptibility, Bulk Cable Injection, 10 kHz to 200 MHz

##### 2.5.2.2.4.1 Conducted Susceptibility, Power and Signal Cables, Common Mode

Applicability: This requirement is applicable to all interconnecting power and signal cables.

Purpose: The purpose of this requirement is to verify the ability of the EUT to withstand common mode currents coupled onto its interface cables. This requirement is intended to be a companion to the Common Mode Conducted Emissions Requirement defined in Section 2.5.2.1.2 in order to mitigate the risk of crosstalk. In many cases, this requirement can replace Electric Field Radiated Susceptibility below 200 MHz.

Limit: The EUT shall not exhibit any malfunction, degradation of performance, or deviation from specified indications beyond the tolerances indicated in the individual equipment or subsystem specification, when subjected to an injection probe drive level which has been pre-calibrated to the GEVS current limit shown in Figure 2.5-21 and is modulated as specified in MIL-STD-461G.

Requirements are also met if the EUT is not susceptible at forward power levels sensed by the directional coupler that are below those determined during calibration provided that the actual current induced in the cable under test is 76 dB $\mu$ A, i.e. 6 dB higher than the level in the plateau portion of the curve, over the entire frequency range, as shown by the red dashed curve in Figure 2.5-21. (This is the injection method specified by MIL-STD-461G, which is different from the method specified by MIL-STD-461F. This is discussed further in section 2.5.3.3.6).

The default limit in Figure 2.5-21 is defined to correspond with the default Radiated Susceptibility on-orbit limit of 2 V/m as defined in section 2.5.2.4.2. If a more stringent on-orbit limit is expected, the limit must be tailored accordingly.

Test Method: The MIL-STD-461G CS114 test method for common mode injection shall apply from 10 kHz to 200 MHz.

Additional discussion of the CS114 limit and test method is provided in section 2.5.3.3.6.

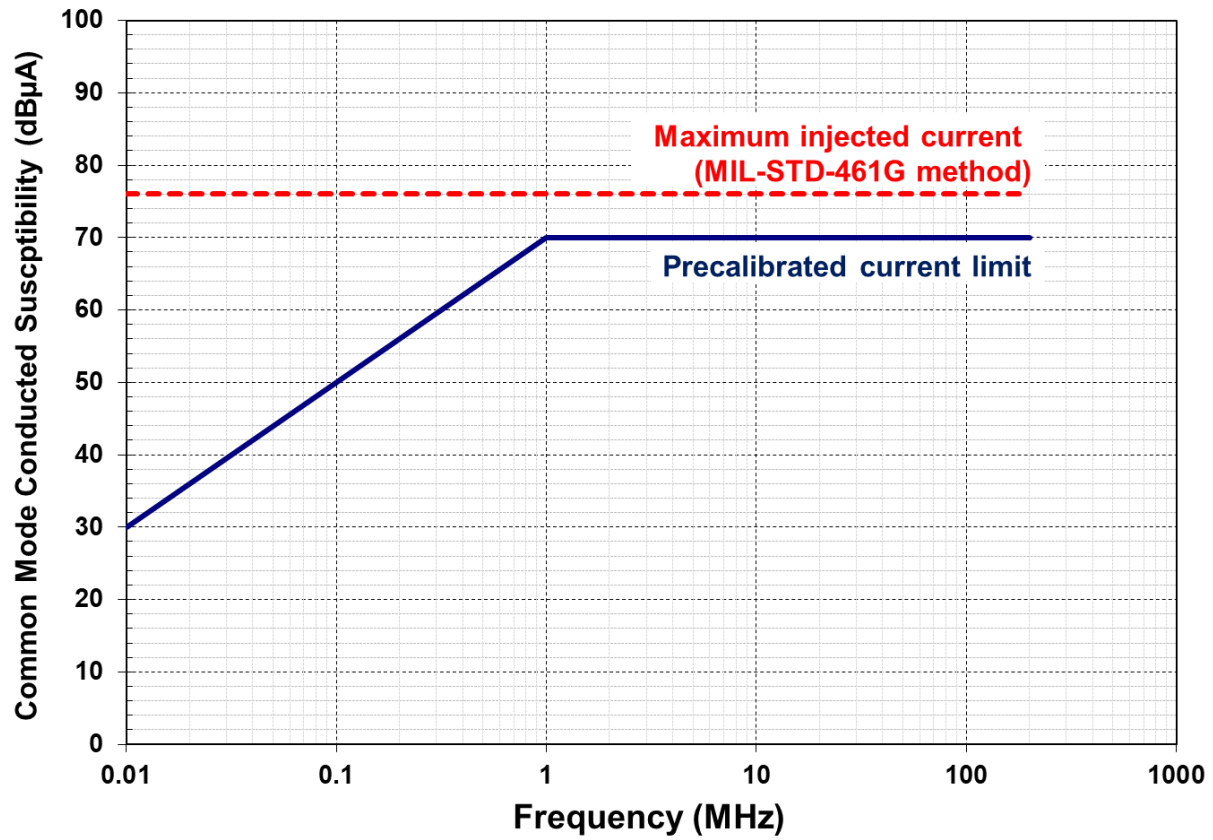

Figure 2.5-21. Common Mode Conducted Susceptibility Current Limits

#### 2.5.2.2.4.2 Conducted Susceptibility, Power Leads, 150 kHz to 50 MHz

Applicability: This requirement is applicable to equipment operating from spacecraft primary power.

Purpose: The purpose of this requirement is to verify the ability of the EUT to withstand ripple on the spacecraft primary power bus.

Limit, Primary: The EUT shall not exhibit any malfunction, degradation of performance, or deviation from specified indications beyond the tolerances indicated in the individual equipment or subsystem specification, when its primary power lead is subjected to the injected potential limit shown in Figure 2.5-22 that is modulated as specified in MIL-STD-461G.

Prior to injection onto the EUT, the injection signal must be pre-calibrated using the MIL-STD-461G CS114 test method to the current limit shown in Figure 2.5-23. This current limit is equivalent to an injected potential of 1 V<sub>rms</sub> into the 100  $\Omega$  in the CS114 calibration fixture. Discussion of the CS114 limit and test method are provided in section 2.5.3.3.6.

Requirements are also met if the source cannot establish the required level at the EUT and the EUT is not susceptible at the forward power levels determined during pre-calibration.

Limit, Alternate: The EUT shall not exhibit any malfunction, degradation of performance, or deviation from specified indications beyond the tolerances indicated in the individual equipment or subsystem specification, when its primary power lead is subjected to an injection probe drive level which has been pre-calibrated to the limit shown by the blue curve in Figure 2.5-22 and that is modulated as specified in MIL-STD-461G.

The maximum allowable injected current levels are shown by the dashed red curve in Figure 2.5-23. Requirements are also met if the EUT is not susceptible at current levels that are below these levels provided that the forward power levels sensed by the directional coupler are equal to the pre-calibrated levels.

Conducted Susceptibility on power leads from 30 Hz to 150 kHz is addressed in Section 2.5.2.2.1.

Additional discussion of the CS114 limit and test method are provided in section 2.5.3.3.6.

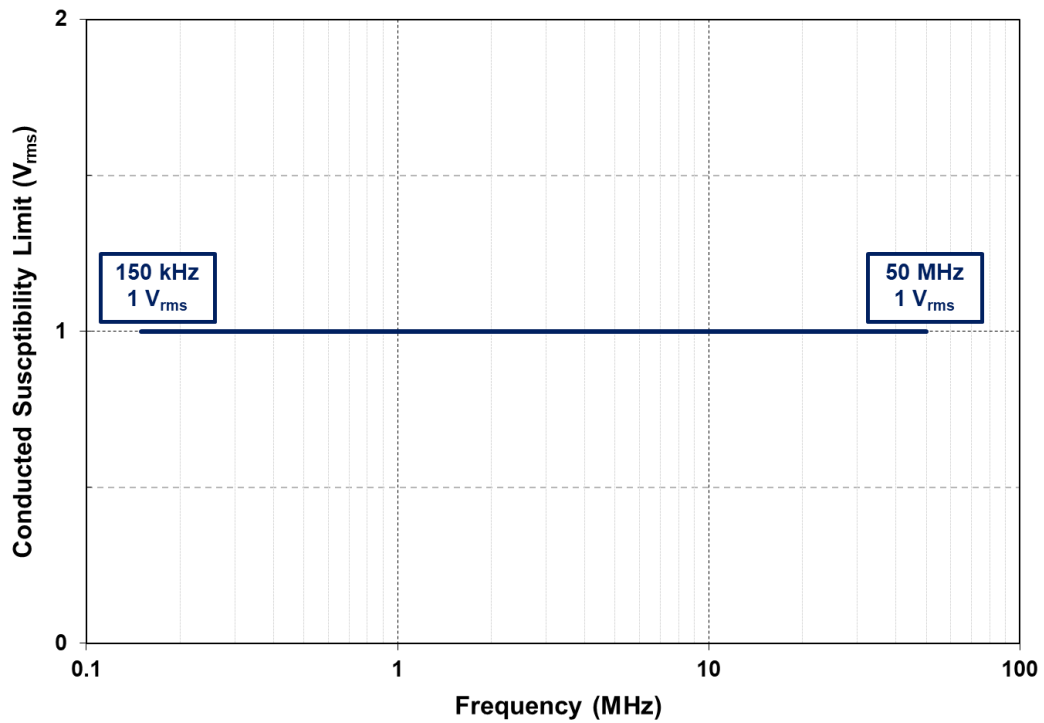

Figure 2.5-22. Conducted Susceptibility, Power Leads, 150 kHz to 50 MHz Voltage Limit

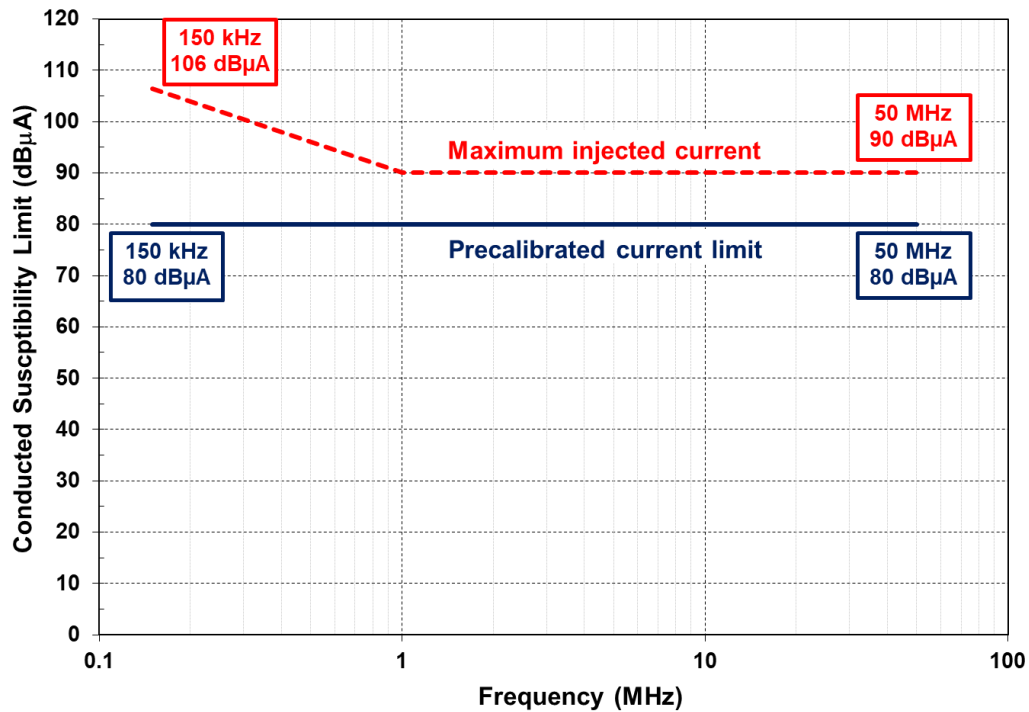

Figure 2.5-23. Conducted Susceptibility, Power Leads, 150 kHz to 50 MHz Current Limits

Check the GSFC Technical Standards Program website at <http://standards.gsfc.nasa.gov> or contact the Executive Secretary for the GSFC Technical Standards Program to verify that this is the correct version prior to use.

**Test Method, Primary:** If the voltage limit shown in Figure 2.5-22 is applied, a modified version of the MIL-STD-461G CS114 test method for injection onto power leads should be applied (per MIL-STD-461G section 5.13.3.4.c) as shown in Figure 2.5-24. This test method directly monitors the injected potential into the EUT instead of the current, as specified in the MIL-STD-461G test method.

In principle, this test method is similar to the MIL-STD-462 CS02 test method with the capacitive coupler replaced with the inductive injection probe.

The differential voltage probe must be placed  $\leq 30$  cm from the EUT, and the injection probe must be placed  $\leq 30$  cm from the voltage probe as shown in Figure 2.5-20. This places both probes within  $\lambda/10$  of the EUT at the upper frequency limit of 50 MHz. These are upper limits on these distances; the probes may be placed as close to the EUT as possible.

Note that this test method requires a dedicated power interface cable that allows for the connection of the differential probe at this point.

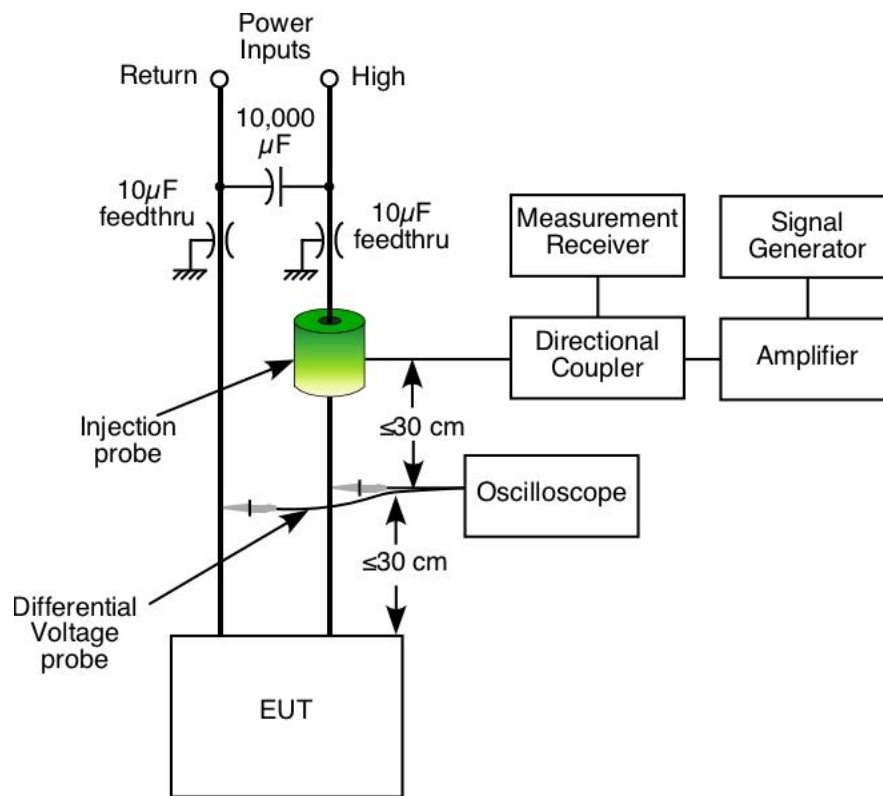
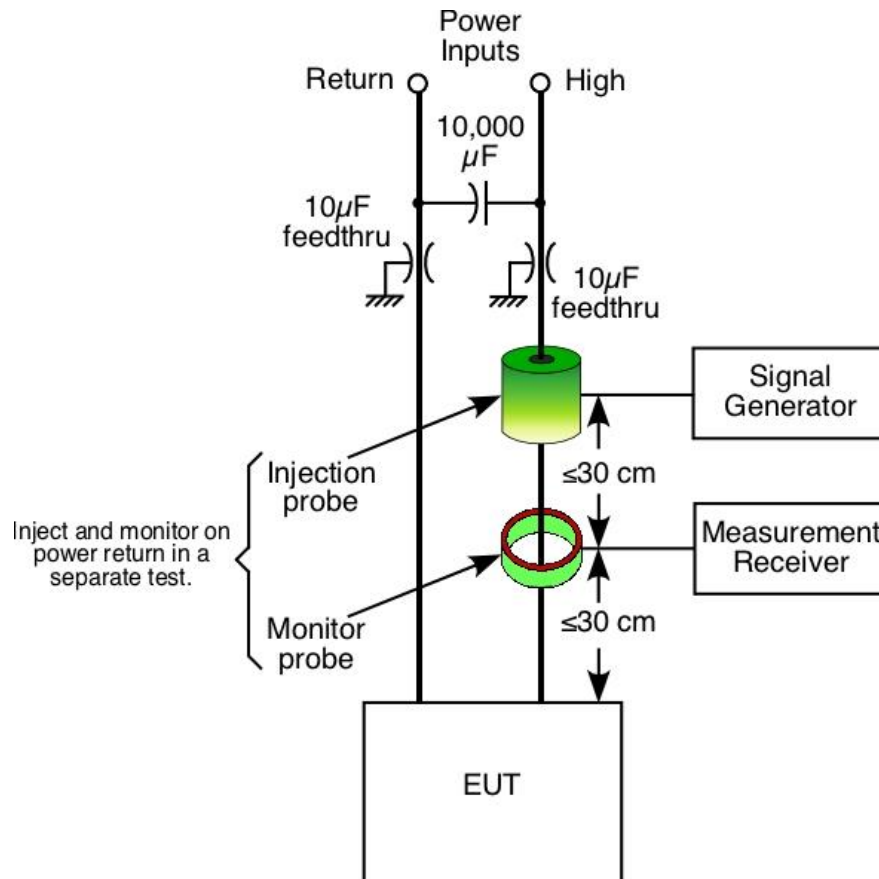

**Figure 2.5-24. Conducted Susceptibility, Power Leads Test Setup**

**Test Method, Alternate:** If the alternate current limit shown in Figure 2.5-23 is applied directly, the common mode injection on the power leads **MUST** be performed first. Due to the nature of injecting on individual power leads as described below, the injection is a combination of common mode and differential mode. If susceptibilities are observed at the same frequencies and with similar signatures to those observed during common mode injection, then they are likely common mode susceptibilities. If different susceptibilities are observed, they are likely differential mode susceptibilities and may be addressed accordingly.

The MIL-STD-461G CS114 test method for injection onto power leads should be applied (per MIL-STD-461G section 5.13.3.4.c) with the following modifications:

- Replace the LISN with the capacitor network described in section 2.5.1.6.2 and as shown in Figure 2.5-24.
- Place the monitor probe  $\leq 30$  cm from the EUT, and place the injection probe  $\leq 30$  cm of the monitor probe as shown in Figure 2.5-25. This places both probes within  $\lambda/10$  of the EUT at the upper frequency limit of 50 MHz. These are upper limits on these distances; the probes may be placed as close to the EUT as possible.
- Perform the scan on each of the high and return leads from 150 kHz to 50 MHz.



**Figure 2.5-25. Conducted Susceptibility, Power Leads Test Setup, Alternate Method**

### 2.5.2.2.5 Conducted Susceptibility, Bulk Cable Injection, Impulse Excitation

**Applicability:** This requirement is applicable to interconnecting power and signal cables that may be subjected to impulse signals.

**Purpose:** This test procedure is used to verify the ability of the EUT to withstand impulse signals coupled onto EUT associated cabling. This test may be used to provide time domain information in addition to the frequency domain information provided by the tailored CS114 test described in the previous section. The basic concern is to protect equipment from fast rise and fall time transients that may be present due to platform switching operations and external transient environments such as lightning, electromagnetic pulse (EMP), space charging, and electrostatic discharge (ESD).

**Test Method:** The MIL-STD-461G CS115 test method shall apply for common mode injection only. Individual power leads need not be broken out, because GSFC platforms do not use platform structure for return.

**Limit:** The CS115 impulse defined in MIL-STD-461G may be applied. This waveform is reproduced in Figure 2.5-26. If a susceptibility is observed, the threshold may be determined as a function of repetition rate as well as amplitude.

The specific definition of what constitutes a “susceptibility” must be determined on a case-by-case basis for each interface. For example, while a digital command/data interface (e.g. SpaceWire) may be temporarily interrupted, the communication protocol should be robust enough to restore the link as quickly as possible and to keep any resulting data loss within acceptable limits. In such cases in which the response to the CS115 stimulus is temporary and normal operations are restored within an acceptable time limit after the stimulus is removed, the response should be noted, but it need not necessarily be indicated as a “susceptibility” or a “failure.”

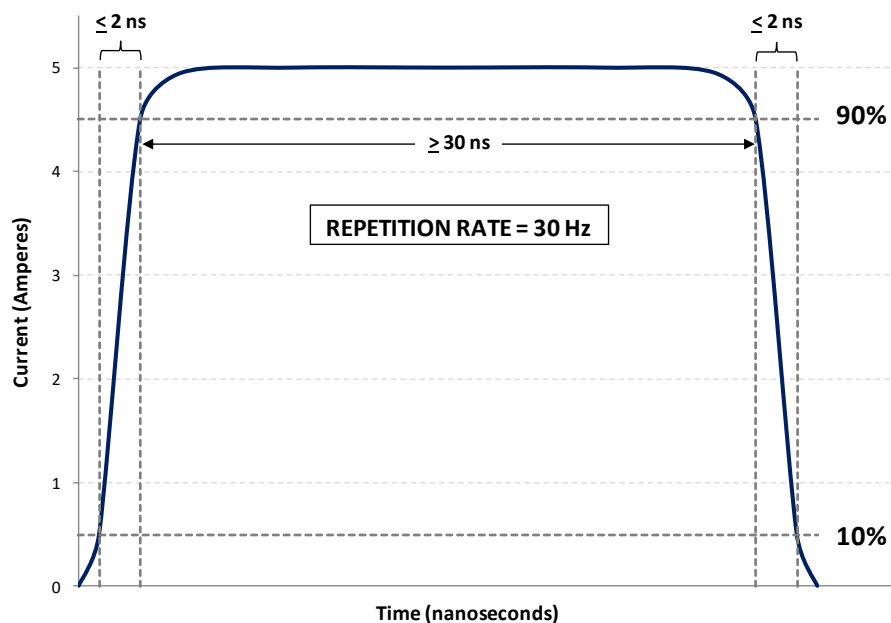

**Figure 2.5-26. CS115 Default Limit**

Check the GSFC Technical Standards Program website at <http://standards.gsfc.nasa.gov> or contact the Executive Secretary for the GSFC Technical Standards Program to verify that this is the correct version prior to use.

#### 2.5.2.2.6 Conducted Susceptibility, Damped Sinusoidal Transients, Cables and Power Leads

Applicability: This requirement is applicable to all interconnecting power and signal cables that may be subjected to damped sinusoidal transients. The need for this test must be determined on a case-by-case basis for each platform.

Purpose: This test procedure is used to verify the ability of the EUT to withstand damped sinusoidal transients coupled onto EUT associated cables and power leads.

Test Method: MIL-STD-461G CS116 test method shall apply.

Limit: The CS116 limit defined in MIL-STD-461G may be applied.

#### 2.5.2.2.7 Conducted Susceptibility, Lightning Induced Transients, Cables and Power Leads

Applicability: This requirement is applicable to all safety-critical equipment interconnecting cables, including complete power cables, and individual high side power leads. It is also applicable to non-safety critical equipment with interconnecting cables/electrical interfaces that are part of or connected to equipment performing safety critical functions. It may be applicable to equipment performing non-safety critical functions when specified by the procuring activity. The need for this test must be determined on a case-by-case basis for each platform.

Purpose: This test procedure is used to verify the ability of the EUT to withstand lightning transients coupled onto EUT associated cables and power leads.

Test Method: MIL-STD-461G CS117 test method shall apply.

Limit: The CS117 limit defined in MIL-STD-461G may be applied.

#### 2.5.2.2.8 Personnel Borne Electrostatic Discharge

Applicability: This requirement is applicable to electrical, electronic, and electromechanical subsystems and equipment that may be subjected to electrostatic discharge (ESD). The need for this test must be determined on a case-by-case basis for each platform.

Purpose: This test procedure is used to verify the ability of the EUT to withstand electrostatic discharge (ESD) in a powered-up configuration.

Test Method: MIL-STD-461G CS118 test method shall apply.

Limit: The CS118 limit defined in MIL-STD-461G may be applied.

### 2.5.2.3 Radiated Emissions Requirements

#### 2.5.2.3.1 Radiated Emissions, Magnetic Field

Applicability: This requirement is applicable to equipment on platforms using devices that are inherently susceptible to magnetic fields either by design or because they process very low-level signals.

Purpose: The purpose of this requirement is to verify that the magnetic field emissions from the EUT and its associated electrical interfaces do not exceed specified requirements.

Test Method: MIL-STD-461G RE101 test method, which measures the magnetic field at a distance of 7 cm from the EUT, may be applied. For some platforms, it may be desirable to also measure the magnetic field at a distance of 1 m from the EUT as specified by the RE04 test method from MIL-STD-462, Notice 2. The 1 m measurement should be performed with a sensor with comparable sensitivity and frequency range to that of the most sensitive potential victim on the platform.

Limit: The limit must be defined and tailored in order to protect equipment on the platform with known sensitivities to magnetic fields. For platforms using such equipment, it is recommended that the project create and maintain a Magnetics Control Plan that defines its magnetic environment and its requirements that have been tailored to that environment. The project may elect to include the Magnetics Control Plan as part of its EMCCP or provide it as a separate document. This plan should be updated and maintained throughout the program.

Guidelines for defining magnetic requirements are provided in “The Design, Construction and Test of Magnetically Clean Spacecraft - A Practical Guide (Mario H. Acuña).”

#### 2.5.2.3.2 Radiated Emissions, Electric Field

Applicability: This requirement is applicable for radiated emissions from equipment and subsystem enclosures, all interconnecting cables, and antennas designed to be permanently mounted to EUTs (receivers and transmitters in standby mode). The requirement does not apply at the transmitter fundamental frequencies and the necessary occupied bandwidth of the signal.

Purpose: The purpose of this requirement is to verify that electric field emissions from the EUT and its associated cabling do not interfere with on-board RF receivers. This requirement is not intended to verify compatibility with neighboring non-RF equipment that has been tested for RS103 that addresses radiated susceptibility to electric fields. While RE102 is concerned with potential effects with antenna-connected receivers, RS103 simulates fields resulting from antenna-connected transmitters.

Limit: The default limit is shown in Figure 2.5-27. The notches shown in the figure are notional only. The limit must be tailored to protect the specific receivers used on the platform.

Test Method: The test method of MIL-STD-461G RE102 may be applied from 200 MHz to 18 GHz.

Guidelines for defining notches to protect receivers are provided in Section 2.5.3.3.7.3.

This requirement and test method are applicable only at frequencies used by antenna-connected receivers. For GSFC platforms, this is generally limited to frequencies above 200 MHz.

Below 200 MHz, the dominant concern is crosstalk, which is addressed by the Common Mode Conducted Emissions requirements defined in Section 2.5.2.1.2 and Common Mode Conducted Susceptibility requirements defined in Section 2.5.2.2.4 (CS114).

If the platform includes receivers that operate at frequencies below 200 MHz, then this requirement and test method must be extended accordingly in order to protect the receivers used at those frequencies.

Guidelines for tailoring the limit and test method are provided in Section 2.5.3.3.7.

Guidelines for defining notches to protect receivers are provided in Section 2.5.3.3.7.3.

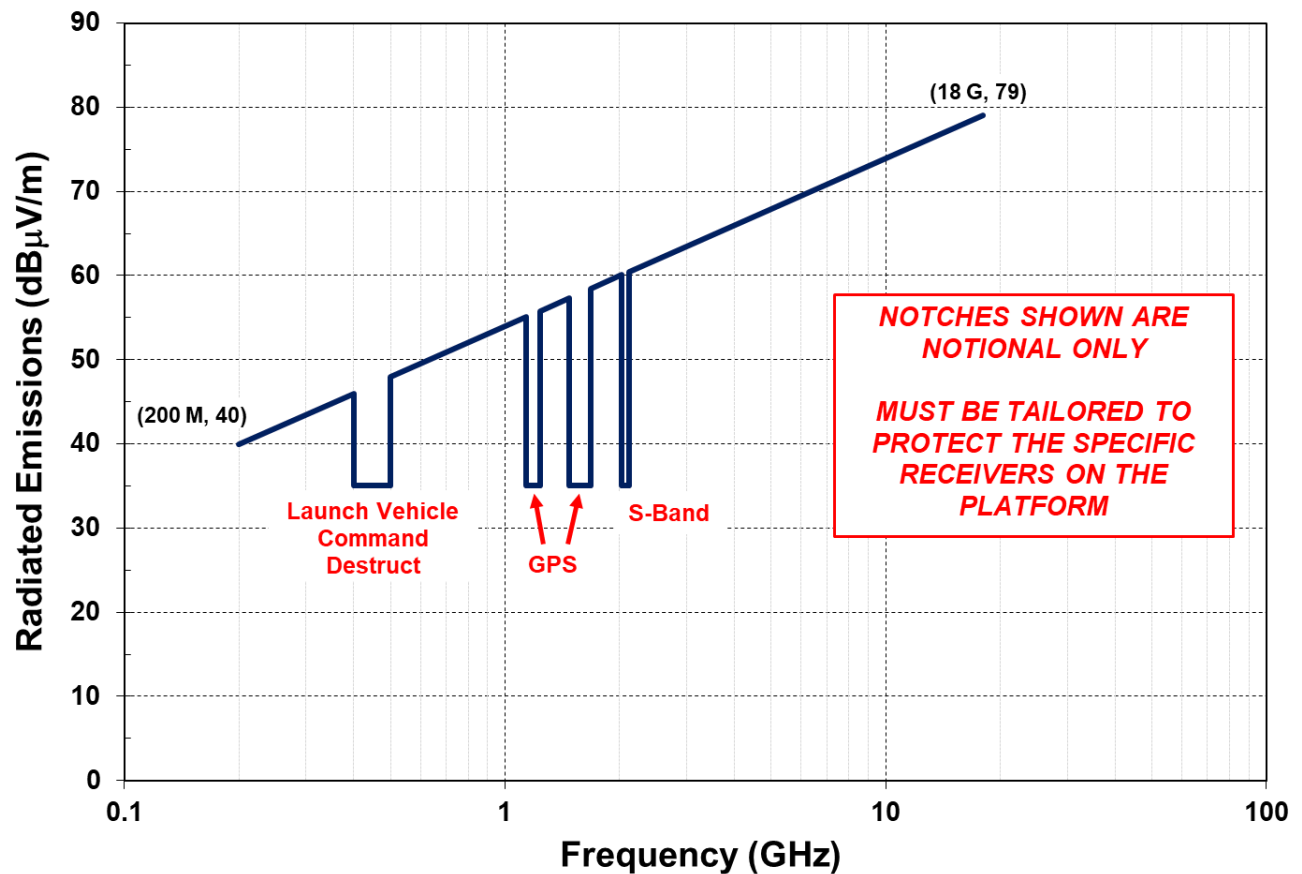

Figure 2.5-27 Radiated Emissions Electric Field Limit with Suggested Notches

#### 2.5.2.4 Radiated Susceptibility Requirements

##### 2.5.2.4.1 Radiated Susceptibility, Magnetic Field

Applicability: This requirement is applicable to equipment on platforms using devices that are inherently susceptible to magnetic fields because they process very low-level, low frequency signals.

Purpose: The purpose of this requirement is to verify the ability of the EUT to withstand radiated magnetic fields.

Limit and Test Method: MIL-STD-461G RS101 test method may be applied for AC magnetic fields. The limits must be defined and tailored according to the equipment used on the platform and documented in the project Magnetics Control Plan (see Section 2.5.2.3.1).

For platforms using equipment sensitive to DC magnetic fields, the test methods as well as the limits defined and documented in the project Magnetics Control Plan.

Guidelines for defining magnetic requirements are provided in “The Design, Construction and Test of Magnetically Clean Spacecraft - A Practical Guide (Mario H. Acuña)”.

#### 2.5.2.4.2 Radiated Susceptibility, Electric Field

Applicability: This requirement is applicable to equipment and subsystem enclosures and all interconnecting cables.

Purpose: The purpose of this requirement is to verify the ability of the EUT and associated cabling to withstand electric fields generated from intentional RF transmitters during all phases of the project, including on orbit, on the launch vehicle, at the launch site, and all test environments. This requirement is not intended to verify compatibility with neighboring non-RF equipment that has been tested for RE102 that addresses electric field radiated emissions. While RE102 is concerned with potential effects with antenna-connected receivers, RS103 simulates fields resulting from antenna-connected transmitters. Compatibility between non-RF components and subsystems is addressed by the Common Mode Conducted Emissions and Bulk Cable Injection Conducted Susceptibility (CS114 test method) requirements.

Test Method: The MIL-STD-461G RS103 test method shall apply.

The general test method of MIL-STD-461G requires real-time monitoring of the applied field using electric field probes.

In some cases, the field may be pre-calibrated using the procedure described in MIL-STD-461F.

Additional discussion of the RS103 test method are provided in section 2.5.3.3.8.

Limit: Equipment that must operate at launch shall be tested, at minimum, to the following levels:

- 20 V/m from 2 MHz to 18 GHz

These limits are based on typical fields from transmitters operating on the launch vehicle and at the launch site. Specific launch vehicles and launch sites may impose different limits. Each project must assess its compatibility to these environments once a launch vehicle and launch site are selected. Further guidance relevant to Launch Vehicle & Launch Site Electromagnetic Environments can be found in the following document:

- ELVL-2010-0042300 Electromagnetic Environments – A Guideline for Spacecraft Launching from Eastern, Western and Pacific Ranges

In addition, the Interface Control Document (ICD) and/or User's Guide for the appropriate launch vehicle must be consulted for further guidance.

Equipment that will not be powered on during launch shall be tested, at minimum, to the following levels:

- 2 V/m from 2 MHz to 18 GHz

These limits are intended to define the minimum on-orbit environment created by the transmitters on board the spacecraft. Specific platforms may impose different limits. Each project must assess its compatibility to the environments defined in the appropriate platform-specific documentation, and the limits must be tailored accordingly.

Based on data and analysis compiled by the Department of Defense Joint Spectrum Center, the on-orbit RF environment can likely exceed 2 V/m in specific frequency bands due to fields transmitted from high gain antennas on the ground or on communications satellites. Susceptibility test levels must be derived from the expected mission environment. Guidance relevant to on-orbit RF environments are provided in the following document:

- JSC-CR-06-070 Space Vehicle RF Environments

Equipment that will not be powered on during launch is only required to survive the launch RS levels without damage. "Survive-without-damage" requirements cannot be verified by test. Such tests are inherently inconclusive; they merely verify that the equipment under test (EUT) shows no obvious damage immediately after being subjected to the test environment. They provide no verification that the EUT was not stressed by the environment. Verification of "survive-without-damage" requirements must inherently be performed by analysis. An approach for such an analysis is outlined in section 2.5.3.3.8.

Equipment that will not be powered on during launch, but that may be powered on during any portion of the test campaign at the launch site, should be tested to the launch site levels in addition to the on-orbit levels. If no susceptibility is observed at the launch site levels, then the equipment may be powered on during the launch site test campaign without restrictions. However, if a susceptibility is observed at the launch site levels but not at the on-orbit levels, the project must assess the risk of interference at the launch site (i.e. fix the interference problem) vs. the need to power up the equipment during the test campaign (i.e. keep the equipment powered off at the launch site).

Additional discussion of the RS103 limits are provided in section 2.5.3.3.8.

### 2.5.2.5 System Level Requirements

Guidance for evaluation of EMC at the system level is provided in MIL-STD-464.

“System level” refers to a higher level of integration than the component level, e.g. instrument/payload level or spacecraft/observatory level.

At minimum, the following tests are recommended:

- Power quality (power bus aggregate voltage ripple, turn-on/turn-off transients)
- Aggregate radiated emissions, electric field (on-orbit and launch levels)
- Aggregate radiated susceptibility, electric field (on-orbit and launch levels)
- System self-compatibility (RF self-compatibility as well as compatibility between non-RF components)

Further discussion of these tests as applied at instrument/payload and spacecraft/observatory levels is provided in the following subsections.

#### 2.5.2.5.1 Power Quality

The standard set of requirements for conducted emissions and conducted susceptibility detailed earlier in this document are, by definition, component level tests intended to provide an early assessment of power quality. There is no reason to repeat these same tests at higher levels of integration.

At higher levels of integration, power quality may be assessed directly with the following measurements, which will be discussed in the following subsections:

- Power bus aggregate voltage ripple, time domain
- Turn-on/turn-off transients

At instrument/payload level, power quality measurements must be performed across a Line Impedance Simulation Network (LISN) placed in series with the spacecraft simulator’s power supply as shown in Figure 2.5-28. The LISN represents the spacecraft primary power bus source impedance and must be defined by the spacecraft provider.

Power quality measurements at spacecraft/observatory level are intended to evaluate the ripple and transients that are seen by all equipment connected to it. As such, these measurements must be performed at the power distribution point in the spacecraft power subsystem, as shown in Figure 2.5-29. Ideally, test points to provide this access must be designed into the power subsystem.

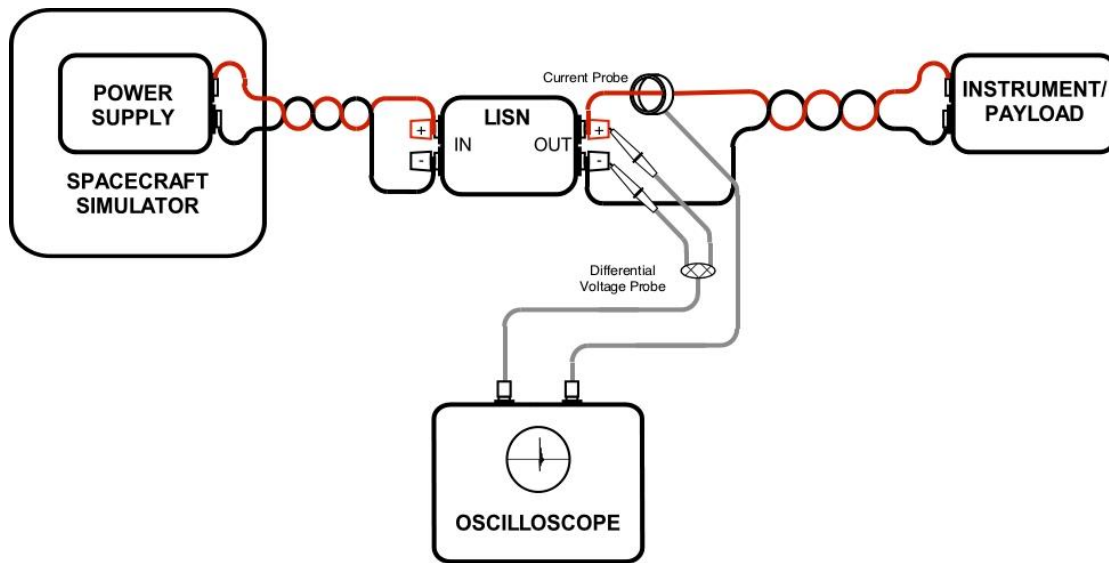

Figure 2.5-28. Recommended Test Setup, Instrument/Payload Level Power Quality Measurements

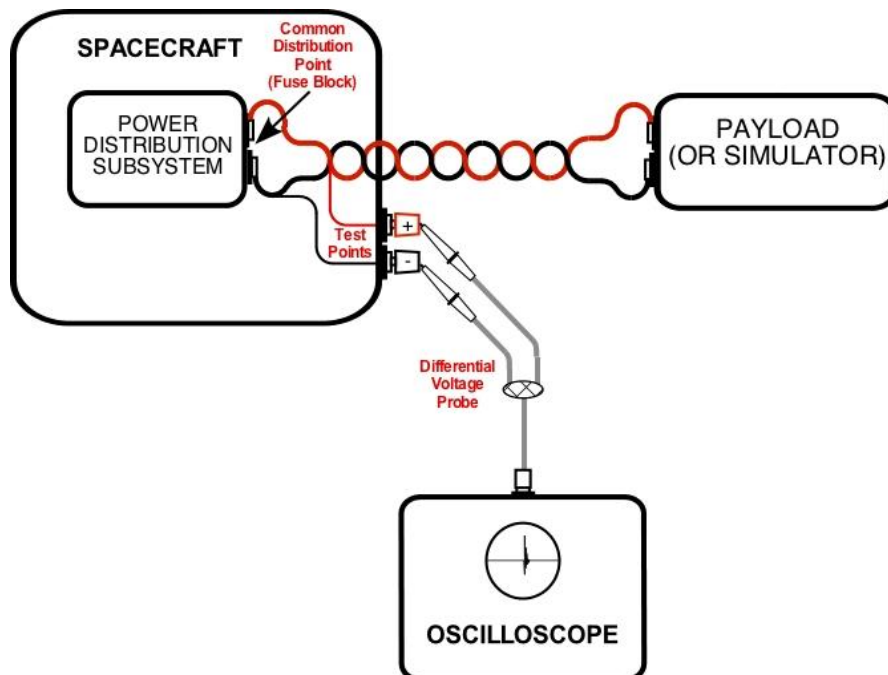

Figure 2.5-29. Recommended Setup, Spacecraft/Observatory Level Power Quality Measurements

Check the GSFC Technical Standards Program website at <http://standards.gsfc.nasa.gov> or contact the Executive Secretary for the GSFC Technical Standards Program to verify that this is the correct version prior to use.

#### 2.5.2.5.1.1 Power Bus Aggregate Voltage Ripple, Time Domain

At the integrated payload, spacecraft, and/or observatory level, it is recommended that a measurement be performed of the aggregate voltage ripple on the primary power bus using the setup shown in Figure 2.5-28 or Figure 2.5-29 while the equipment is put through a typical mission sequence.

A recommended limit is that the aggregate ripple should not exceed 1 volt peak-to-peak when measured in the time domain with a bandwidth limit of 20 MHz.

#### 2.5.2.5.1.2 Turn-On/Turn-Off Transients

As equipment is switched on and off of the primary power bus, the resulting voltage and current transients imposed on the bus should be measured using the setup shown in Figure 2.5-28 or Figure 2.5-29.

Turn-on transients are expected to induce a sag (negative-going pulse) on the primary power bus. As each unit is switched onto the bus in the test configuration, the turn-on voltage transient should be measured and compared against the negative applied CS06 pulse discussed in section 2.5.2.2.3, to which all of the units should have been tested.

Turn-off transients are expected to induce a surge (positive-going pulse) on the primary power bus. As each unit is switched off of the bus in the test configuration, the turn-off voltage transient should be measured and compared against the positive applied CS06 pulse discussed in section 2.5.2.2.3, to which all of the units should have been tested.

The current transients may also be measured in addition to the voltage transients. For time-domain current measurements, a current probe test must be selected that has a flat transfer impedance at least from 20 Hz to 1 MHz in order to ensure accurate reproductions of waveforms with a resolution of approximately 1 microsecond. A typical oscilloscope current probe is preferred unless its window is too small to fit around the power wire bundle. For larger bundles, the recommended probe is the Pearson 3525.

#### 2.5.2.5.2 Aggregate Radiated Emissions, Electric Field (On-Orbit and Launch Levels)

The aggregate radiated emissions should be measured at integrated payload, spacecraft, and/or observatory levels.

At instrument/payload level, it is only necessary to perform measurements in frequency bands occupied by intentional receivers on the platform and at the launch site, generally defined by the notches in the radiated emissions limit. In addition, measurement antenna locations may be limited to locations that are representative of the relative locations of the antennas on the platform and at the launch site that are being protected by the defined radiated emissions limits.

At spacecraft/observatory level, it is only necessary to perform measurements in frequency bands occupied by intentional receivers at the launch site, generally defined by the notches in the radiated emissions limit. In addition, measurement antenna locations may be limited to locations that are representative of the relative locations of the antennas on the launch vehicle and at the launch site that are being protected by the defined radiated emissions limits.

This is NOT to be considered a repeat of the RE102 test performed at component level. RE102 is, by definition, a unit level test. Use of the RE102 nomenclature for tests at higher levels of integration has been shown to cause confusion and **must be avoided**.

#### 2.5.2.5.3 Aggregate Radiated Susceptibility, Electric Field (On-Orbit and Launch Levels)

The aggregate radiated susceptibility should be evaluated at integrated payload, spacecraft, and/or observatory levels.

At instrument/payload level, it is only necessary to perform measurements in frequency bands occupied by intentional transmitters on the launch vehicle, on the spacecraft, and at the launch site, generally defined by the “tent poles” in the radiated susceptibility limit. In addition, measurement antenna locations may be limited to locations that are representative of the relative locations of the transmitting antennas on the platform and at the launch site.

At spacecraft/observatory levels, it is only necessary to perform measurements in frequency bands occupied by intentional transmitters on the launch vehicle and at the launch site, generally defined by the “tent poles” in the radiated susceptibility limit. In addition, measurement antenna locations may be limited to locations that are representative of the relative locations of the transmitting antennas on the launch vehicle and at the launch site.

This is NOT to be considered a repeat of the RS103 test performed at component level. RS103 is, by definition, a unit level test. Use of the RS103 nomenclature for tests at higher levels of integration has been shown to cause confusion and **must be avoided**.

#### 2.5.2.5.4 System Self-Compatibility

System self-compatibility is addressed in two parts:

- RF self-compatibility
- Compatibility between non-RF components

##### 2.5.2.5.4.1 RF Self-Compatibility

RF self-compatibility is addressed in two parts:

- RF communications subsystem as possible victim
- RF communications subsystem as possible culprit

##### 2.5.2.5.4.1.1 RF Communications Subsystem as Possible Victim

The first part of RF self-compatibility addresses the on-board RF communications subsystem as a possible victim. The intent is to evaluate the risk of interference to on-board RF receivers due to unintentional emissions from the rest of the spacecraft/observatory.

MIL-STD-464C (section 5.1, "Margins") specifies that "safety critical and mission critical system functions shall have a margin of at least 6 dB," and that "compliance shall be verified by test, analysis, or a combination thereof."

Because the RF uplink is certainly a mission critical function, the 6 dB margin must be verified at integrated spacecraft and/or observatory level.

A straightforward technique to verify the 6 dB margin requirement is to apply an uplink signal that is 6 dB below minimum level specified by the link budget while the spacecraft/observatory is operated through a typical mission sequence. If the on-board communications subsystem maintains lock on the uplink signal while the spacecraft is generating its maximum RF emissions, this demonstrates indirectly that the spacecraft RF background is at least 6 dB below maximum noise level that will allow the minimum signal level specified by the link budget to meet its SNR requirements, thereby demonstrating that the 6 dB margin requirement is met.

The above technique is applicable and totally satisfactory as long as the number of possible uplink frequencies is very small such that evaluating the link at each frequency over the course of an integration test does not prolong the test schedule to an unacceptable degree. If there are many more frequencies than could be practically evaluated in a reasonable amount of time, then the technique specified by MIL-STD-464C is recommended and is summarized below.

Disconnect the coaxial cable from the uplink antenna at the on-board uplink receiver's input, then connect it to a test receiver or spectrum analyzer sweeping the frequency band of the uplink receiver. The spacecraft/observatory is operated through a mission sequence profile, and the noise picked up by the antenna in the uplink receiver band is measured using a bandwidth commensurate with the bandwidth of the on-board receiver. The measured noise level in the receiver band must be at least 6 dB below the maximum permissible noise level that will allow the minimum signal level specified by the link budget to meet its signal-to-noise ratio (SNR) requirements.

#### 2.5.2.5.4.1.2 RF Communications Subsystem as Possible Culprit

The second part of RF self-compatibility addresses the on-board RF communications subsystem as a possible culprit. The intent is to evaluate the risk of interference to rest of the spacecraft/observatory due to the intentional emissions from the on-board RF transmitters.

In principle, this portion of the test is straightforward. The RF communications system is placed in its most emissive on-orbit mode while the non-RF equipment is operated through a mission sequence profile. If all non-RF equipment operates within specifications during the entire mission sequence, then compatibility is demonstrated

#### 2.5.2.5.4.2 Compatibility Between Non-RF Components

Compatibility between non-RF components is generally addressed during the Comprehensive Performance Test (CPT), during which all of the equipment is put through a normal mission sequence.

While the primary purpose of the CPT is to evaluate the performance of each component, it provides an opportunity to determine if any component is interfering with any other components.

Prior to performing the CPT, it is recommended that a list of likely culprits and victims be created. Time should be planned into the CPT to evaluate the response of the most likely victims (e.g. detector subsystems) to the most likely culprits (e.g. motors).

### 2.5.3. Application Guide

For EMC requirements, GEVS uses MIL-STD-461G as its point of departure. A brief history of MIL-STD-461 is provided in the following subsection.

This application guide, along with the Appendix of MIL-STD-461G, provides background information for each emission and susceptibility and associated test requirement in the previous sections of this document. This information includes rationale for requirements, guidance in applying the requirements, and lessons learned from platform and laboratory experience. This information should help users understand the intent behind the requirements, should aid the procuring activity in tailoring emission and susceptibility requirements as necessary for particular applications, and should help users develop detailed test procedures in the EMITP based on the general test procedures in this document. This section is provided for guidance purposes and, as such, should not be interpreted as providing contractual requirements.

Each EMI test addresses at least one of the following concerns:

- Compatibility with the spacecraft power subsystem
- Compatibility with the spacecraft communications subsystem
- Compatibility between subsystems (crosstalk)

The EMI tests specified by MIL-STD-461 primarily address the first two concerns with little to no emphasis on the third. Compatibility with the spacecraft power subsystem is addressed through Conducted Emissions (CE101, CE102) and Conducted Susceptibility (CS101, CS114 on power lines) requirements; compatibility with the spacecraft communications subsystem is addressed through Electric Field Radiated Emissions (RE102) and Electric Field Radiated Susceptibility (RS103) requirements.

Regarding RE102 and RS103, Section A.5.17 of MIL-STD-461G states:

“There is no implied relationship between (RE102) and RS103 that addresses radiated susceptibility to electric fields. Attempts have been made quite frequently in the past to compare electric field radiated emission and susceptibility type requirements as a justification for deviations and waivers. While RE102 is concerned with potential effects with antenna-connected receivers, RS103 simulates fields resulting from antenna-connected transmitters.”

In other words, RE102 and RS103 are specifically designed to assess compatibility with the communications subsystem. They are not designed to address crosstalk between subsystems.

When an EUT meets these requirements on a military platform, there is generally low risk of crosstalk. This is primarily because the default RE102 limit corresponds to common mode current levels on culprit cables that are too low to pose a significant risk. Outside the frequency bands of antenna-connected receivers, the RE102 levels (and those of its MIL-STD-461C predecessor, RE02) are significantly more stringent than necessary to control crosstalk. This is precisely the reason that RE02 and RE102 exceedances have historically been the largest sources of waivers on many GSFC platforms.

Section A.5.17 of MIL-STD-461G provides the following tailoring guideline:

“It may be desirable to tailor the frequency coverage of the limit to include only frequency bands where antenna-connected receivers are present.”

Most GSFC platforms do not use the antenna-connected receivers that operate at frequencies below 200 MHz. Following this guideline, RE102 is only applicable above 200 MHz on most GSFC platforms as discussed in Section 2.5.2.3.2.

On such platforms, crosstalk replaces RE102 as the dominant concern below 200 MHz. The crosstalk concern is addressed with a measurement of Common Mode Conducted Emissions (CMCE, no MIL-STD-461G equivalent) on power and signal cables as defined in Section 2.5.2.1.2. This requirement is intended to be a companion to the Common Mode Conducted Susceptibility (CMCS, MIL-STD-461G CS114 test method) requirement as defined in Section 2.5.2.2.4. The results of these two tests enable a significantly more direct and efficient assessment of cable-to-cable crosstalk than is possible using RE102 and RS103.

An extensive discussion of crosstalk is provided in the GEVS application note entitled, “Inductive Crosstalk at the System Level,” available on the “GEVS Application Notes” page of the GSFC EMC Working Group SPACES site:

<https://spaces.gsfc.nasa.gov/display/EMCWG/GEVS+Application+Notes>

The approach outlined above is adapted from the tailored RE102 requirements and test methods defined in SL-E-0002, Space Shuttle Specification, Electromagnetic Interference Characteristics, Requirements for Equipment. This specification replaces the traditional RE102 test method below 200 MHz with a Bulk Cable Emission (BCE) measurement for all of the reasons stated above. This approach has been demonstrated to control cable-to-cable crosstalk more effectively and efficiently while at the same time eliminating the paperwork associated with waivers against an inapplicable and unnecessarily stringent RE102 limit below 200 MHz.

### 2.5.3.1 A Brief History of MIL-STD-461

This section provides a comparison of the core requirements and test methods of the different versions of MIL-STD-461 and its obsolete companion standard MIL-STD-462. It further provides the rationale for GEVS’ specification of a particular requirement/test method in each case. In most cases, GEVS specifies requirements and test methods from MIL-STD-461G. In some isolated cases, GEVS specifies a requirement/test method from obsolete MIL-STD-461C/462 when it provides a better fit for platform needs (e.g. CE03 and CS06 as discussed below).

#### 2.5.3.1.1 Nomenclature

One obvious cosmetic difference is that MIL-STD-461D (requirements) and MIL-STD-462D (test methods), both released in 1993, introduced new nomenclature, e.g. CE101, CS101, RE102, etc., which is a departure from the previous nomenclature used by MIL-STD-461C and earlier, e.g. CE01, CS01, RE02, etc. This updated nomenclature has continued with the release of MIL-STD-461E in 1999, MIL-STD-461G in 2007, and MIL-STD-461G in 2015.

The core requirements and test methods using the newer nomenclature will be compared against their respective predecessors in the discussion of specific requirements below. The main difference that led to the nomenclature shift concerned the power source impedance; MIL-STD-461D/462D specified the use of Line Impedance Stabilization Networks (LISNs), while MIL-STD-461C and earlier specified the use of 10  $\mu$ F feedthrough capacitors. This will be discussed further in the “Power Source Impedance” section below.

#### 2.5.3.1.2 Document Organization

MIL-STD-461D and -462D introduced an Application Guide in the appendix in order to provide additional engineering context for the requirements and test methods.

MIL-STD-461E, released in 1999, combined the requirements and the test methods into a single document, and MIL-STD-462 was discontinued as a separate document. That format has continued in versions F and G.

In the remainder of this section, any references to specific sections, tables, or figures pertain to MIL-STD-461E and later.

#### 2.5.3.1.3 Verification Requirements

MIL-STD-461E and later provide a number of “verification requirements” in section 4.3, i.e. requirements on the general test setup and approach before defining any of the requirements for specific tests.

These include requirements for the following, for which there are no equivalents in MIL-STD-461C and earlier:

- Radio frequency (RF) absorber material (section 4.3.2.1, Table I)
- Power source impedance (section 4.3.6; discussed in next section of this document)
- Measurement bandwidth and measurement times for emissions testing (section 4.3.10.3.1, Table II\*)
- Scan rates/step sizes for susceptibility testing (section 4.3.10.4.1, Table III)
- Modulation of susceptibility signals (section 4.3.10.4.2)

MIL-STD-461G Table II provides requirements for the proper use of FFT-based receivers for emissions measurements.

Additional guidance is provided in MIL-STD-461G section A.4.3.10.3.3.

MIL-STD-461G also introduced new requirements on the calibration of measurement equipment in section 4.3.11.

GEVS applies these verification requirements with some tailoring as indicated in section 2.5.1.5.

#### 2.5.3.1.4 Power Source Impedance

A standardized power source impedance is defined in order to represent expected impedances on actual platforms and to ensure consistent results between different test facilities. MIL-STD-461D/-462D and later specify the use of LISNs, while MIL-STD-461C and earlier specify the use of a pair of 10  $\mu$ F feedthrough capacitors. A thorough discussion of this topic is provided in section 2.5.3.2.2 of this document and in section A.4.3.6 of the Application Guide of MIL-STD-461G.

#### 2.5.3.1.5 Conducted Emissions (CE)

CE101 (Conducted Emissions, Power Leads, Audio Frequencies) is a current measurement that is essentially identical to its CE01 predecessor except for the upper frequency limit. CE101 is specified to 10 kHz, while CE01 is specified up to 20 kHz. With the substitution of the capacitor network for the LISNs, CE101 basically the same measurement as CE01 using the same test equipment.

CE102 (Conducted Emissions, Power Leads, Radio Frequencies) is a voltage measurement across a LISN. CE03 is a current measurement from the capacitor network. Because GEVS recommends the capacitor network shown in Figure 2.5-1 to replace the LISNs, GEVS applies the CE03 test method. A thorough discussion of this topic is provided in section 2.5.3.3.1.

GEVS further specifies that these CE measurements be performed as true differential mode (DM) measurements as specified in section 2.5.2.1.1 and as common mode (CM) measurements as specified in section 2.5.2.1.2. The CM measurements are performed on signal cables as well as power leads.

A true DM measurement is performed with the return (-) power lead routed through the current probe in the opposite direction to the high (+) lead as shown in Figure 2.5-4 and Figure 2.5-5. The DM measurement specifically addresses power quality, i.e. ripple on the primary power bus. The true DM measurement is unique to GEVS; it is not specified in any version of MIL-STD-461.

The common mode conducted emissions (CMCE) measurement directly addresses crosstalk when paired with the CS114 test on bulk cables (discussed in CS section below). These CMCE measurements are very similar to the CE02 and CE04 test methods of MIL-STD-462; there is no equivalent to these measurements in MIL-STD-461D and later.

An extensive discussion of the relationship between conducted and radiated emissions is provided in the GEVS application note entitled, "Radiated Emissions as a Function of Common Mode Current," available on the "GEVS Application Notes" page of the GSFC EMC Working Group SPACES site:

<https://spaces.gsfc.nasa.gov/display/EMCWG/GEVS+Application+Notes>

GEVS also specifies a measurement of inrush current as defined in section 2.5.2.1.3, along with further discussion in section 2.5.3.3.3. Inrush current measurements are not specified in any version of MIL-STD-461.

### 2.5.3.1.6 Conducted Susceptibility (CS)

CS101 (Conducted Susceptibility, Power Leads, Audio Frequencies) is very similar to its CS01 predecessor except for the upper frequency limit. CS101 is specified up to 150 kHz, while CS01 is specified up to 50 kHz. With the substitution of the capacitor network for the LISNs, which provides a low source impedance that guarantees that essentially all of the injected ripple drops across the test sample, CS101 is basically the same test method as CS01 using the same test equipment. A more thorough discussion is provided in section 2.5.3.3.4.

The CS101 limit is defined in MIL-STD-461D and later in order to provide margin with respect to the ripple originating from electromechanical power sources typically used on aircraft. GSFC spacecraft generally implement a battery dominated bus, as represented by the GEVS capacitor network. The source impedance of a battery dominated bus is much lower than that of an electromechanical source, which results in much lower ripple, especially at lower frequencies. The inherently lower ripple from such sources leads to the GEVS tailored limit that permits an alternative test method using a clamp-on injection probe, which protects flight hardware from possible damage inherent in the traditional method using an injection transformer. Further discussion is provided in section 2.5.3.3.4.

CS02 (Conducted Susceptibility, Power Leads, Radio Frequencies) is a capacitively coupled voltage injection method from MIL-STD-462. This is a dated test method with many pitfalls; GEVS replaces it with the CS114 test method of MIL-STD-461G. An extensive comparison between these two test methods is provided in the GEVS application note entitled, "CS114 vs. CS02 – Conducted Susceptibility," available on the "GEVS Application Notes" page of the GSFC EMC Working Group SPACES site:

<https://spaces.gsfc.nasa.gov/display/EMCWG/GEVS+Application+Notes>

In addition to being a replacement for CS02, CS114 is primarily used for bulk cable injection (BCI) on power and signal cables. In GEVS, this is also called a test of common mode conducted susceptibility (CMCS), which may be paired with the CMCE test in order to directly address crosstalk concerns. There is no equivalent to CS114 in MIL-STD-461C and earlier.

An extensive discussion of crosstalk is provided in the GEVS application note entitled, "Inductive Crosstalk at the System Level," also available at the link above for the "GEVS Application Notes" page.

CS06 (Conducted Susceptibility, Transients) from MIL-STD-461C specifies a 10 microsecond pulse. There is no equivalent to this test in MIL-STD-461D/462D or MIL-STD-461E. MIL-STD-461F introduced CS106 specifically for Navy applications, submarine and surface ship equipment in particular, and specified a 5 microsecond pulse to represent the typical transient observed on these platforms. CS106 fell out of favor and is not included in MIL-STD-461G. Considering all of these factors, GEVS recommends a tailored version of the CS06 test method with the 10 microsecond pulse imposed taking the nominal bus potential to zero, simulating a turn-on transient. Further discussion is provided in section 2.5.3.3.5.

MIL-STD-461D/462D introduced CS115 (Conducted Susceptibility, Bulk Cable Injection, Impulse Excitation), which has been carried through versions E, F, and G. The basic concern is to protect equipment from fast rise and fall time transients that may be present due to platform switching operations and external transient environments such as lightning, electromagnetic pulse (EMP), space charging, and electrostatic discharge (ESD). CS115 is a replacement for requirements like RS02 (pulse) and RS06 chattering relay, both in MIL-STD-461C.

MIL-STD-461D/462D also introduced CS116 (Conducted Susceptibility, Damped Sinusoidal Transients, Cables and Power Leads, 10 kHz to 100 MHz) to simulate responses to external stimuli such as EMP, and it has been carried through versions E, F, and G. CS116 has direct predecessors CS10/11/12/13 in MIL-STD-461C, and MIL-STD-462, Notices 5 & 6.

MIL-STD-461G introduced CS117 (Conducted Susceptibility, Lightning Induced Transients, Cables and Power Leads) as an additional test to specifically simulate response to lightning strikes. There is no equivalent to this test in earlier versions of MIL-STD-461.

MIL-STD-461G also introduced CS118 (Personnel Borne Electrostatic Discharge) to address effects of electrostatic discharging on electrical and electronic equipment caused by human electrostatic discharge (ESD). The test equipment and procedures are based upon internationally recognized standards such as IEC 61000-4-2. There is no equivalent to this test in earlier versions of MIL-STD-461.

GEVS specifies CS114 and CS115 on all GSFC platforms. Applicability of CS116, CS117, and CS118 must be addressed on a case-by-case basis.

#### 2.5.3.1.7 Radiated Emissions (RE)

RE101 (Radiated Emissions, Magnetic Field) is essentially identical to its RE01 predecessor.

RE102 (Radiated Emissions, Electric Field) is, in its general concept, similar to its RE02 predecessor. However, it introduces more realistic limits and some modified test methods using different antennas and configuration. In particular, MIL-STD-461F introduced updates to the rod antenna measurement configuration in the frequency range of 14 kHz to 30 MHz in order to address known deficiencies with that test method. GEVS applies RE102 at frequencies in which RF receivers are used on the platform, which is in most cases limited to frequencies above 200 MHz. This eliminates the difficulties associated with the rod antenna. In addition, GEVS favors the use of log spiral antennas over the standard double-ridged guide (DRG) horn antennas, which makes it a bit more closely aligned with RE02. Additional discussion is provided in section 2.5.3.3.7.

#### 2.5.3.1.8 Radiated Susceptibility (RS)

RS101 (Radiated Susceptibility, Magnetic Field) is essentially identical to its RS01 predecessor.

RS103 (Radiated Susceptibility, Electric Field) is similar to its RS03 predecessor. The main difference is that for RS103, the applied field is monitored using electric field probes, while for RS03, the applied field is precalibrated with a receive antenna. Because electric field probes are the standard devices used for this test at GSFC, even when a project specifies RS03, it is likely that the RS103 test method is being implemented.

### 2.5.3.2 Test Facility and Procedure Requirements

#### 2.5.3.2.1 Ambient Electromagnetic Level

Noise from Electrical Ground Support Equipment (EGSE) is one of the most common contributors to high ambient levels. If the EGSE cables penetrate the chamber wall in an uncontrolled manner as shown in Figure 2.5-30, common mode currents are allowed to enter the chamber along with their resulting electric and magnetic fields. These fields will raise the ambient electromagnetic field level, quite possibly to a level that violates the requirement stated in Section 2.5.1.5.1.

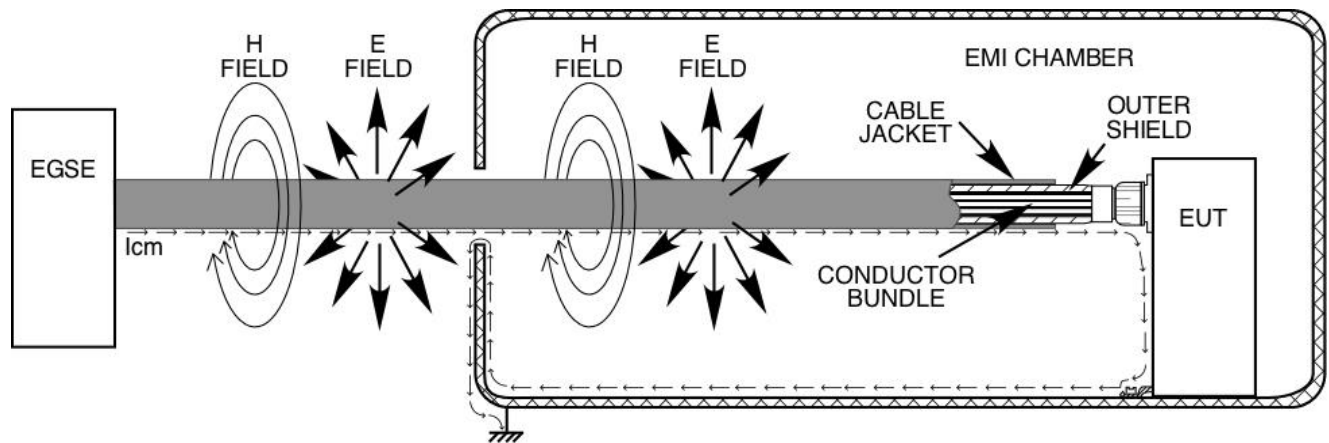

**Figure 2.5-30. Impacts of Uncontrolled EGSE Common Mode Currents**

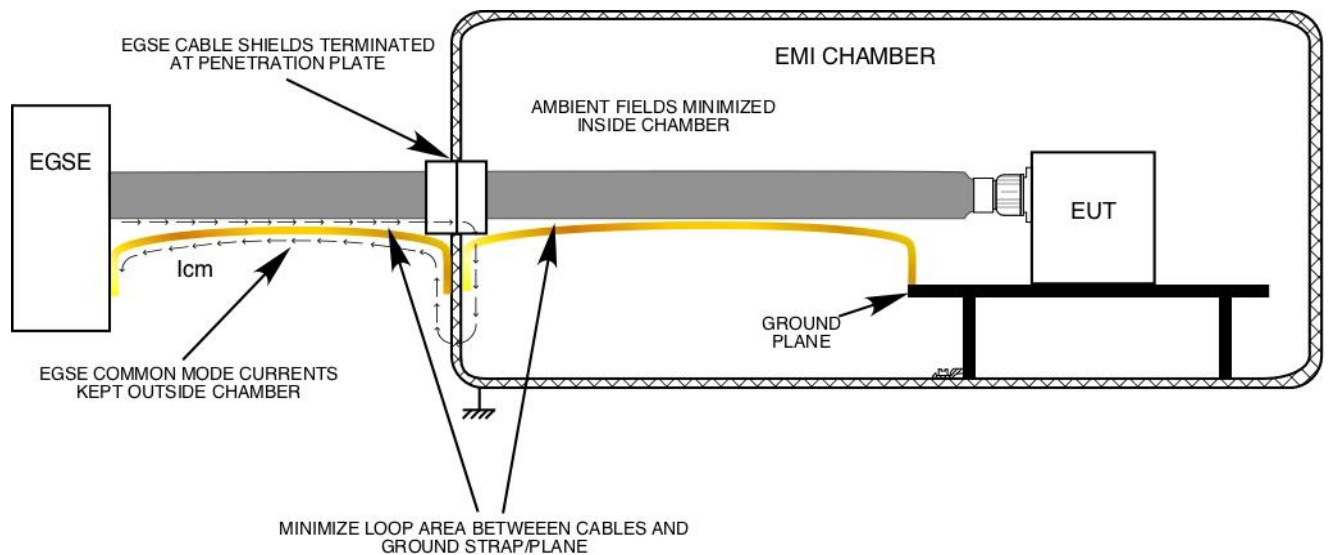

**Figure 2.5-31. Proper EGSE Shielding and Grounding Configuration**

Check the GSFC Technical Standards Program website at <http://standards.gsfc.nasa.gov> or contact the Executive Secretary for the GSFC Technical Standards Program to verify that this is the correct version prior to use.

In order to prevent these uncontrolled currents and fields from entering the chamber, all outer shields of all EGSE cables should be terminated at the chamber wall, and a single point ground should be established at the feedthrough panel as shown in Figure 2.5-31. Common mode currents on the EGSE cables are thereby prevented from entering the chamber and do not contribute to the ambient level.

The preferred method for terminating the shields is to provide a connector break at the chamber feedthrough panel as shown in Figure 2.5-32. The outer shield of each cable is connected directly to its backshell with 360-degree coverage, and the mating connector is connected directly to the feedthrough panel, preferably with an EMI gasket.

An alternate method is to run the cables through a stuffing tube as shown in Figure 2.5-33. The outer jacket of the cables inside the stuffing tube must be removed in order to expose the shield, and the tube should be filled with stainless steel, bronze, or copper wool in order to provide electrical continuity (bonding) between the shield braid(s) and the inside of the stuffing tube wall.

For EMI test facilities in which contamination and cleanliness are a significant concern, the stuffing tube may not be used. These facilities must implement the connector break and terminate the shields at the feedthrough panel.

Additional guidance for grounding, bonding, and shielding for facilities and test configurations is provided in MIL-HDBK-419A, Grounding, Bonding, and Shielding for Electronic Equipments and Facilities (Volumes 1 & 2, 29 December 1987).

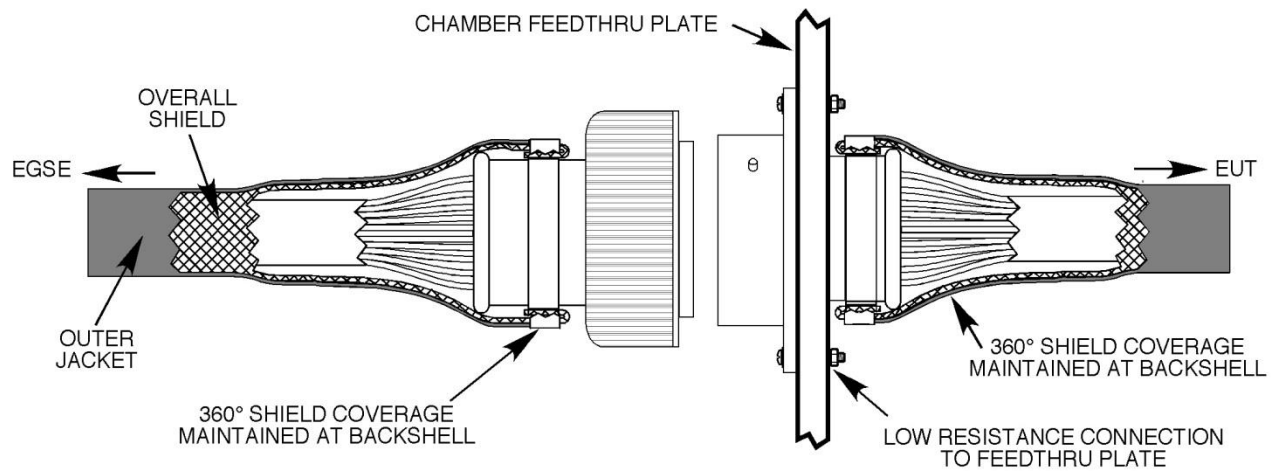

**Figure 2.5-32. EGSE Cable Shield Termination – Connector Break (Preferred Method)**

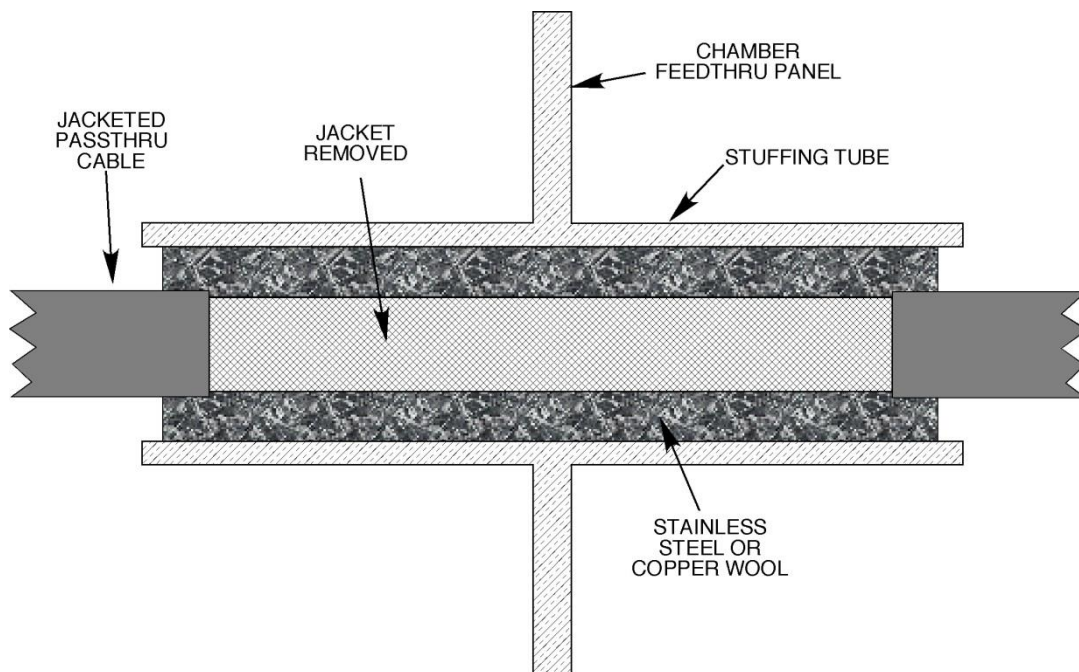

**Figure 2.5-33. EGSE Cable Shield Termination – Stuffing Tube (Alternate Method)**

### 2.5.3.2.2 Power Source Impedance

MIL-STD-461G specifies the use of Line Impedance Stabilization Networks (LISNs) in series with the power leads to the EUT. The purpose of the LISNs is to provide a standardized power bus source impedance to represent expected impedances in actual installations and to ensure consistent results between different test facilities. The LISN is intended to simulate the common source impedance between the spacecraft power supply and the common distribution point as shown in Figure 2.5-34. It is not intended to include the harness impedance between the common distribution point and the load; this portion of the impedance is most effectively simulated using flight representative cables.

LISNs are discussed in further detail in MIL-STD-461G section A.4.3.6.

MIL-STD-461G Section 4.3.6 specifies a default 50  $\mu\text{H}$  LISN. This LISN simulates worst-case power distribution wiring on large military platforms as shown in Figure 2.5-35. On such platforms, power is distributed as a single wire 5 cm above structure (chassis), and structure is used as the current return path. This wiring configuration has an inductance on the order of 1  $\mu\text{H}/\text{m}$ . In the worst case, the wiring may run as much as 50 meters to the common distribution point, which gives the worst-case total inductance of 50  $\mu\text{H}$  specified in the default MIL-STD-461G LISN.

On the majority of GSFC platforms, the power distribution wiring more closely resembles that shown in Figure 2.5-36. The power source impedance consists of a battery-dominated bus charged from solar cells, with the point of distribution (fuse block or other circuit protection devices) mounted in the immediate vicinity of the battery (< 1 m), providing for very low wiring contribution to the common or shared bus impedance.

In addition, the chassis is almost never used as a deliberate current return path. A dedicated return wire is generally twisted with the “send” or “hot” wire, which results in a lower inductance (< 0.5  $\mu\text{H}/\text{m}$  typical). For such platforms, the power source impedance is significantly less than that simulated by the 50  $\mu\text{H}$  LISN. The impedance is more accurately simulated by the capacitor network shown schematically in Figure 2.5-37, which consists of a 10,000  $\mu\text{F}$  line-to-line capacitor, shunted by a pair of 10  $\mu\text{F}$  feedthrough capacitors installed between each power conductor and the ground plane.

The 10  $\mu\text{F}$  feedthrough capacitors form an integral part of the standard setup specified by MIL-STD-462 and are part of the standard suite of equipment available in any EMI laboratory. These feedthrough capacitors provide a standard source impedance (< 1  $\Omega$ ) at frequencies above approximately 20 kHz. Because MIL-STD-461 and MIL-STD-462 also apply to platforms with AC power sources operating at 60 Hz or 400 Hz, this level of control was generally considered sufficient.

However, GSFC platforms usually implement battery dominated DC power busses, and it is desirable to provide a low source impedance down to 30 Hz. The 10,000  $\mu\text{F}$  line-to-line capacitor extends the standardized source impedance (< 1  $\Omega$ ) down to 30 Hz in order to cover the full range of frequencies specified by the tests in this document. For all MIL-STD-461G based test methods specified in this document, the LISNs will be replaced by this capacitor network.

The 10,000  $\mu\text{F}$  capacitor may be placed on either side of the pair of 10  $\mu\text{F}$  feedthrough capacitors. No discernable difference is observed in the source impedance of the network in either configuration. Measurements documenting these findings are provided in the summary slides entitled, "GEVS Impedance Control Capacitor Bank, Insertion Loss Measurements IAW SAE ARP-936," which are available on the on the GSFC EMC Working Group site:

<https://spaces.gsfc.nasa.gov/display/EMCWG/GEVS+Application+Notes>

If a given GSFC program identifies a need to use a LISN, it is recommended to follow the tailoring guidelines of MIL-STD-461G section A.4.3.6, which specifies a 5  $\mu\text{H}$  LISN as shown in MIL-STD-461G Figure A-2 (schematic) and MIL-STD-461G Figure A-3 (impedance). If the flight power distribution scheme is well defined and the 5  $\mu\text{H}$  LISN is also unrealistically high, a custom LISN or flight representative cables may be used. The specific LISN or test cables used will be specified in the project EMCCP along with supporting rationale.

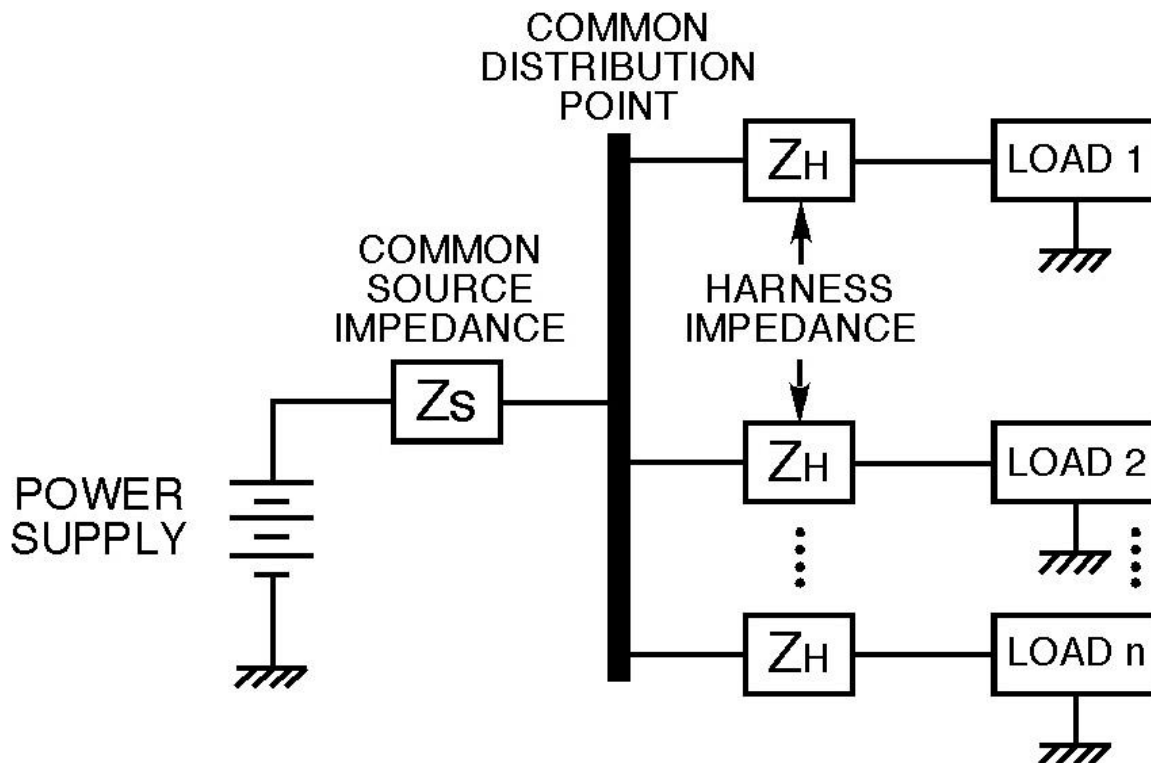

Figure 2.5-34. Common Source Impedance and Harness Impedance (General)

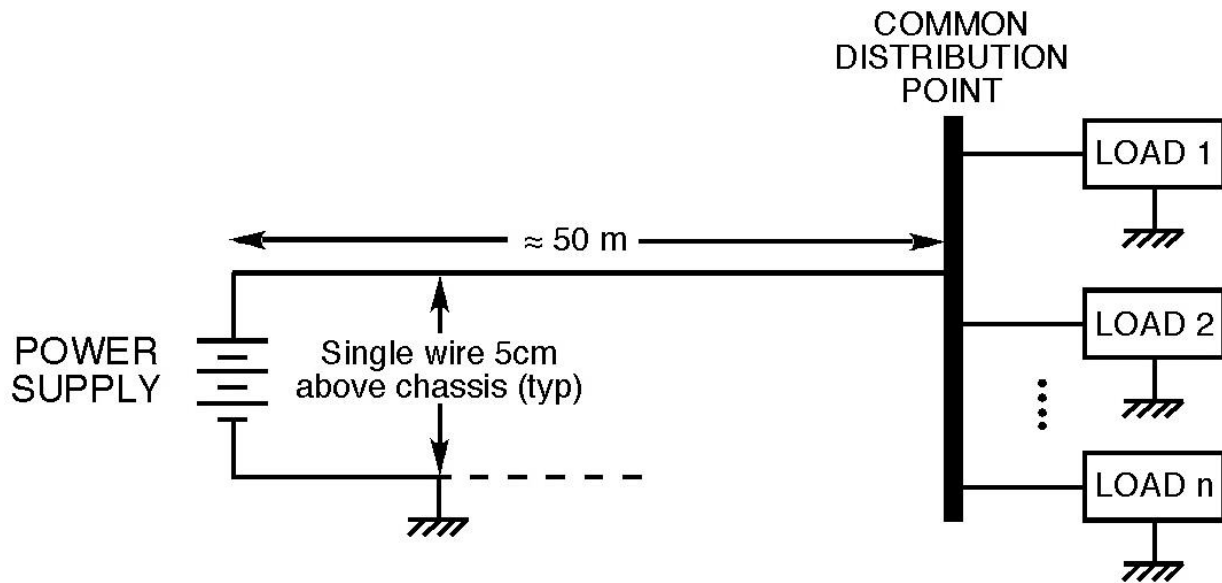

Figure 2.5-35. Power Distribution Wiring, Large Military Platforms (Worst Case)

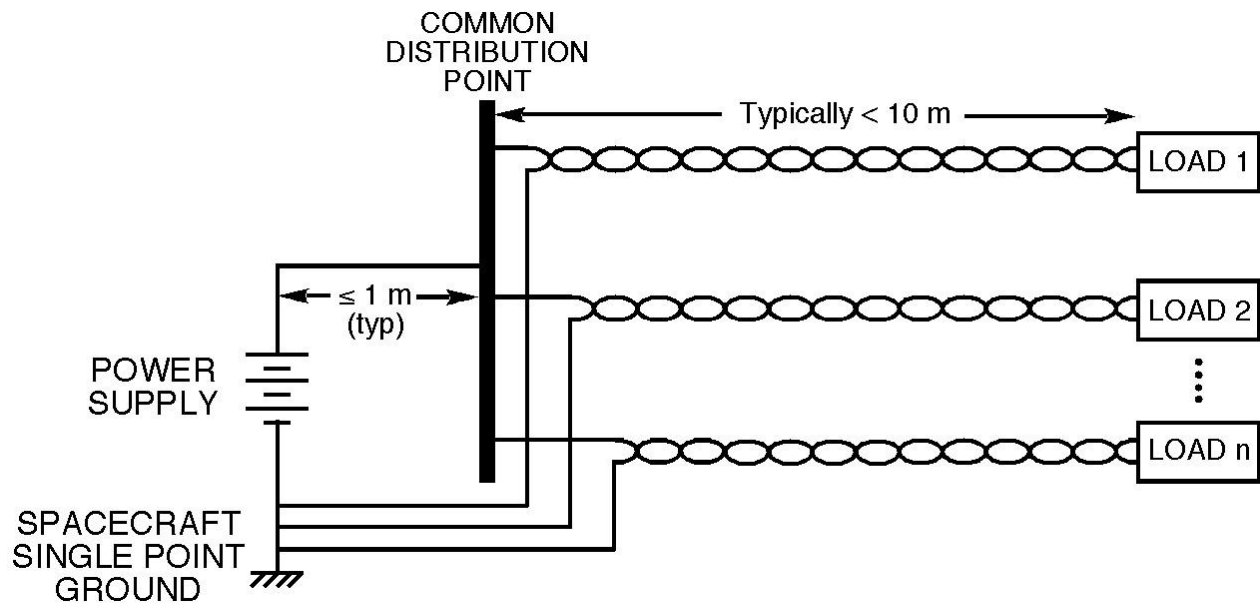
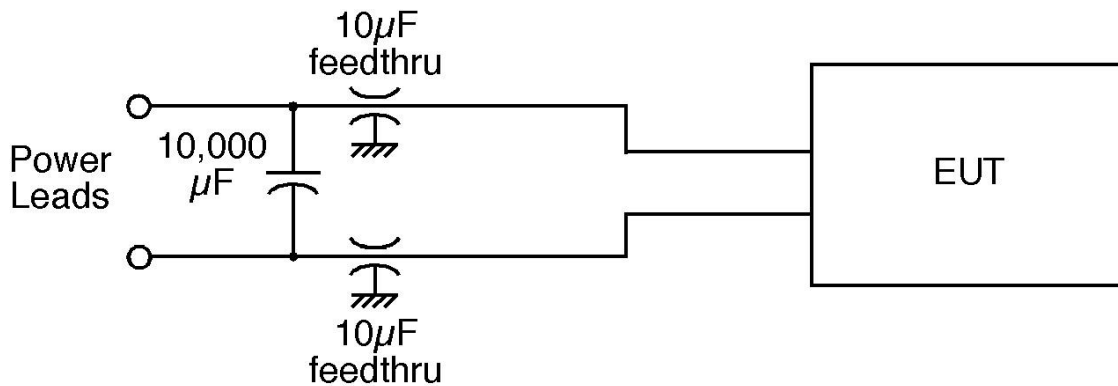

Figure 2.5-36. Power Distribution Wiring, GSFC Platforms (Typical)



**Figure 2.5-37. Capacitor Network Simulating Battery Dominated Bus Impedance**

### 2.5.3.2.3 Construction and Arrangement of EUT Cables

As stated in Section 2.5.1.5.2 of this document, the power source impedance for the tests in this document will be simulated by the capacitor network shown in Figure 2.5-1. The 10 μF feedthrough capacitors are an integral part of the standard setup specified by MIL-STD-462. The CE01 and CE03 test methods of MIL-STD-462, the predecessors of CE101 and CE102, specify that the “length of power lead from the test sample to the feedthrough capacitor shall not exceed 1 meter.” This clearly conflicts with the following requirement in MIL-STD-461G Section 4.3.8.6.2: “Two meters of input power leads (including neutrals and returns) shall be routed parallel to the front edge of the setup in the same manner as the interconnecting leads.”

It is recommended to use the 2 meter length as specified by MIL-STD-462. The rationale for this recommendation is provided below.

The purpose of the 1 m maximum length specified by MIL-STD-462 is to minimize standing waves by ensuring that the cables are electrically short (less than a significant fraction of a wavelength) over the CE01 and CE03 frequency range. The wavelength  $\lambda$  in meters of an electromagnetic wave is given by:

$$\lambda = \frac{c}{f}$$

where:

$$c = \text{speed of light} = 3 \times 10^8 \text{ m/s}$$

$$f = \text{frequency}$$

Wavelength is alternately expressed as follows:

$$\lambda = \frac{300}{f_{\text{MHz}}}$$

At the CE03 upper frequency limit of 50 MHz,  $\lambda = 6$  m. The 1 m cable is a sixth of a wavelength ( $\lambda/6$ ), which is sufficiently electrically short through this frequency range.

The purpose of the 2 m minimum length specified by MIL-STD-461G is to ensure that radiated emissions and susceptibility testing properly assesses the performance of the EUT along with all of its interconnecting cables. In order for the interconnecting cables to be properly assessed, they must be electrically long (greater than a significant fraction of a wavelength) over most of the frequency range covered by the tests. This is particularly important for the radiated electric field emissions (RE102) and susceptibility (RS103) tests, for which the nominal frequency range specified by MIL-STD-461G is 2 MHz to 18 GHz.

As discussed in detail in section 2.5.3.3.2.2, an electrically long interconnecting cable must be treated as a wire-above-ground transmission line. The unshielded power leads connect to the feedthrough capacitors, which are designed to present an effective short to the ground plane above 20 kHz, which covers all of the frequencies at which the leads are electrically long. For shielded signal cables, the shield is generally terminated to chassis at both ends. In either case, the transmission line will effectively be terminated with a short instead of with its characteristic impedance. This means that reflections and standing waves will develop along the length of the cable, resulting in non-uniform potential and current distributions along its length.

The analysis in section 2.5.3.3.2.2 further shows that a current maximum occurs at the load end at all frequencies. For the power cables, the load end corresponds to the capacitor network as shown in Figure 2.5-2. Thus, for current measurements on power leads, both differential mode (DM) and common mode (CM), the current probe should be placed adjacent to the capacitor network in order to capture the maximum amplitude at all frequencies of interest.

For the signal cables, the load end corresponds to the access panel, where the shields should be terminated. (A discussion of cable shield terminations is provided in section 2.5.3.2.1.) Thus, for common mode current measurements on signal cables, the current probe should be placed as close to the access panel as possible.

For these reasons, 1 meter power leads are no longer deemed necessary. The test objectives may be accomplished just as effectively with 2-meter power leads. Furthermore, use of the 2-meter power leads re-establishes consistency with MIL-STD-461G and helps mitigate further confusion.

### 2.5.3.3 Detailed Requirements

#### 2.5.3.3.1 Conducted Emissions, Power Leads, Differential Mode

The CE101 test method (and its CE01 predecessor) is a single-ended line-to-ground current measurement as shown in Figure 2.5-38. This test method originates from military architectures in which power is distributed to each load in a single-ended manner and uses structure as the return path. This scheme is almost never used on GSFC platforms; dedicated return wires are almost always provided in present GSFC power distribution schemes.

These single-ended measurements combine differential mode (DM) and common mode (CM) information, which unnecessarily complicates the process of diagnosing and addressing the effects of the measured emissions. Separating the DM and CM measurements provides more directly meaningful limits and more useful information for diagnosing the source of a given emission and for assessing its potential impacts.

The MIL-STD-461G test method CE102 specifies a voltage measurement across a LISN. When conducted emissions are measured as a voltage, the results depend significantly on the power bus source impedance, which can vary from platform to platform. For this reason and for the reasons discussed above, a DM current measurement across the capacitor network is preferred as specified in Section 2.5.2.1.1. This test method provides a worst-case measurement of DM current emissions that is largely independent of the source impedance. The measured DM current may be directly compared to the platform's power bus impedance in order to assess the contribution to power bus voltage ripple.

This is effectively the basic MIL-STD-462 CE03 test method with the send and return wires run through the current probe for a DM measurement. It is also very similar to the tailored CE101 test method described above; the primary difference consists of the selection of a current probe that is suited to the higher (CE03) frequency range.

The Common Mode Conducted Emissions (CMCE) measurements are defined in Section 2.5.2.1.2.

The current probe must be placed within 5 cm of the capacitor network. This is particularly true at the upper end of the CE03 frequency range, where the current distribution along the line will not be uniform due to standing waves. Placing the current probe adjacent to the capacitor network will ensure that the maximum current is captured at all frequencies. Further discussion of current distribution and standing waves is provided in section 2.5.3.2.2.

Because the DM test method measures twice the true DM mode current (6 dB above the true value), the measured limit must be set 6 dB above the true maximum DM mode current. The limits below 150 kHz are based on the CE101 tailoring guidelines in MIL-STD-461G Section A.5.4; the limits above 150 kHz are based on the CE03 limits of MIL-STD-461C.

The frequency breakpoint between the low and high frequency portions is 150 kHz. The limit at 150 kHz is fixed at 62 dB $\mu$ A, which is 6 dB above the tailored CE101 limit at 150 kHz as specified in MIL-STD-461G Section A.5.4.

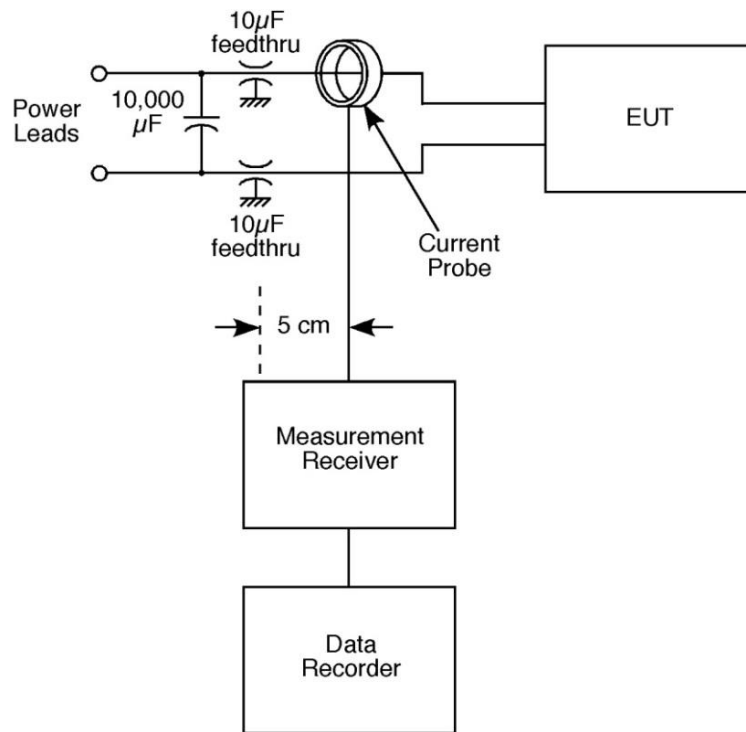

**Figure 2.5-38. Conducted Emissions Test Setup – Single-Ended (Traditional)**

#### 2.5.3.3.2 Conducted Emissions, Common Mode, Power and Signal Lines

This test method addresses cable-to-cable crosstalk at frequencies up to 200 MHz. If the platform implements particularly sensitive cables with known compromised shielding performance (e.g. cryogenic cables with high resistance shields), it is recommended that the susceptibility of such victim cables be characterized first as specified by the Common Mode Conducted Susceptibility test (CS114) defined in Section 2.5.2.2.4. If any cable is susceptible to levels lower than the default limit, it may be necessary to define a minimum separation from potential culprit cables.

Guidance for addressing crosstalk and cable separation is provided in the GEVS application note entitled, “Inductive Crosstalk at the System Level.” A brief summary is provided in section 2.5.3.3.2.3.

Emissions above 200 MHz are addressed by the Radiated Electric Field Emissions (RE102) requirement defined in section 2.5.2.3.2.

An extensive discussion of the relationship between conducted and radiated emissions is provided in the GEVS application note entitled, “Radiated Emissions as a Function of Common Mode Current.” A brief summary is provided in section 2.5.3.3.2.2.

Both application notes are available on the “GEVS Application Notes” page of the GSFC EMC Working Group SPACES site:

<https://spaces.gsfc.nasa.gov/display/EMCWG/GEVS+Application+Notes>

Check the GSFC Technical Standards Program website at <http://standards.gsfc.nasa.gov> or contact the Executive Secretary for the GSFC Technical Standards Program to verify that this is the correct version prior to use.

When performing CMCE measurements on a cable, the cable must be considered a wire-above-ground transmission line, the parameters of which are discussed in section 2.5.3.3.9. The general case for CMCE measurements is that of a shielded cable with the shield terminated to chassis on both ends of the cable. This means that the wire-above-ground transmission line will not be terminated in its characteristic impedance. The terminating impedance on each end will be near  $0 \Omega$ , which will result in reflections on each end and standing waves along the length of the cable. This behavior, and its implications for CMCE measurements, is discussed in detail in section 2.5.3.3.2.4.

The absorbing clamp test method is discussed in the following section.

#### 2.5.3.3.2.1 Absorbing Clamp Test Method, 30 MHz to 200 MHz

CISPR 16 specifies the absorbing clamp for use in the frequency range of 30 MHz to 1 GHz. The previous version of this standard specified the use of the absorbing clamp from 150 kHz to 200 MHz, following the example of SL-E-0002, which requires the clamp to be calibrated differently from CISPR 16. Below 30 MHz, the added inductance of the clamp was found to lower the measured current and to shift the pattern of peaks and nulls (described in section 2.5.3.3.2.2) by changing the effective electrical length of the cable. In this version of this standard, it was decided to limit the use of the absorbing clamp to frequencies above 30 MHz, where it is most effective.

Above 30 MHz, the cable is “electrically long” and must be considered a mismatched wire-above ground transmission line. It will exhibit the pattern of peaks and nulls discussed in detail in section 2.5.3.3.2.2.

In this frequency range, using a standard current probe may result in artificially high level at a peak frequency or an artificially low level at a null frequency. In the former case, this could cause an apparent test failure for a level that may be benign with the different cable layout in the flight configuration. In the latter case, it could mask a real emission from the EUT that could be more significant in the flight configuration. Moreover, as discussed in sections 2.5.3.3.2.2 and 2.5.3.3.2.3, the dominant factor is the net integrated average current, not the peaks and nulls. In any event, using a standard current probe for CMCE measurements above 30 MHz may produce skewed results that may not be directly applicable to the flight configuration.

What is desired is a means of the inserting a resistive, or absorbing, impedance in the line above 30 MHz in order to dampen the peaks and nulls and provide a normalized measurement of EUT emissions in this frequency range.

This function is performed by the absorbing clamp (fully described in CISPR 16), and it is the central piece of equipment for CMCE measurements in this frequency range. It is a current probe followed by a series of ferrite ring absorber elements. These add the desired resistive impedance above 30 MHz and act to isolate the rest of the cable, minimizing the standing waves associated with signals on an electrically long mismatched transmission line.

In order to get the full value of the absorbing clamp, it must be set up with the current probe end of the device within 15 cm ( $\lambda/10$  at 200 MHz) of the EUT.

### 2.5.3.3.2.1.1 Absorbing Clamp Calibration Procedure

In order to use the absorbing clamp for this test, it must be calibrated as a current probe, not as an absorbing clamp per CISPR 16. The manufacturer may be requested to do this, or it can be done in-house using the general setup shown in Figure 2.5-39.

A single spectrum analyzer may be used for both measurements. If this approach is used, a 50  $\Omega$  terminator must be connected to the port that is not being measured.

The version of this setup specified in CISPR 16 includes a 10 dB pad at each end of the calibration fixture, along with a 6 dB pad at the current output of the absorbing clamp, in order to minimize the effects of impedance mismatches at each of these interfaces. These pads may certainly be used, but they will reduce the available signal to a level that may be comparable to the noise floor of the measurement system.

If necessary, a low power amplifier may be connected in series with the signal generator output in order to raise the level of the injected signal level in order to obtain a more accurate measurement.

The general procedure is as follows:

- 1) This method uses two L-brackets with bulkhead mount BNC or N-type connectors on either side of the CISPR 16 absorbing clamp. The signal generator and spectrum analyzer attach to the connectors with coax. The center pins of the connectors are connected by a solid copper wire, 12 to 20 AWG in size, approximately one meter in length. The absorbing clamp is placed around the wire, with the current probe side of the clamp (indicated by dashed line) as close as possible to the end attached to spectrum analyzer #1, but in no case more than 15 cm away from the terminating end of the fixture where spectrum analyzer #1 is located. The outer conductor of the connector is bonded to the L-bracket, which is in turn bonded to the ground plane beneath the absorbing clamp.
- 2) Set the terminating spectrum analyzer (#1) to sweep from 30 MHz to 200 MHz, continuous sweep, max hold, and so that the data is measured in dB $\mu$ A, if possible. Otherwise, set it to read in dB $\mu$ V.
- 3) Connect the output of the absorbing clamp into 50  $\Omega$  input of spectrum analyzer #2, and set this spectrum analyzer to sweep from 30 MHz to 200 MHz, continuous sweep, max hold, and so that the data is measured in dB $\mu$ V.
- 4) Set the signal generator output to -10 dBm. Sweep the signal generator from 30 MHz to 200 MHz, using a sweep time of between 100 ms and 500 ms.
- 5) If the terminating spectrum analyzer #1 is not able to display the data in dB $\mu$ A, the current into spectrum analyzer #1, and Thus, through the absorbing clamp current probe, can be calculated from the voltage read at spectrum analyzer #1 using the following relationship:

$$I \text{ (dB}\mu\text{A)} = V \text{ (dB}\mu\text{V)} - 34 \text{ dB}\Omega$$

- 6) Verify that the voltage measured by the absorbing clamp and displayed on spectrum analyzer #2 (in  $\text{dB}\mu\text{V}$ ) minus the detected current displayed on spectrum analyzer #1 (in  $\text{dB}\mu\text{A}$ ) results in a value that closely approximates the transfer impedance given by the curve in Figure 2.5-40. Retain the derived transfer impedance data for use in later calculations during the testing phase of the BCE procedure.

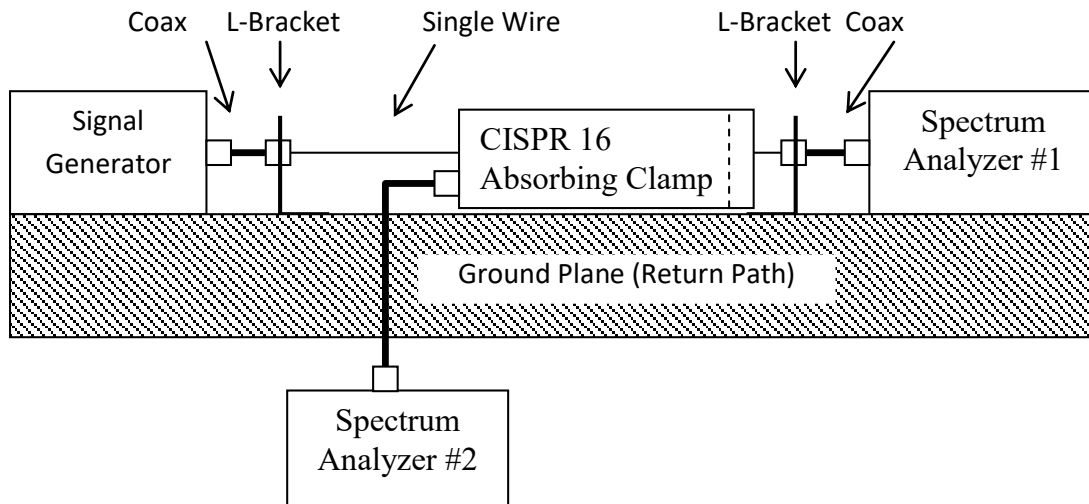

Figure 2.5-39. Basic Common Mode Conducted Emissions Calibration Setup

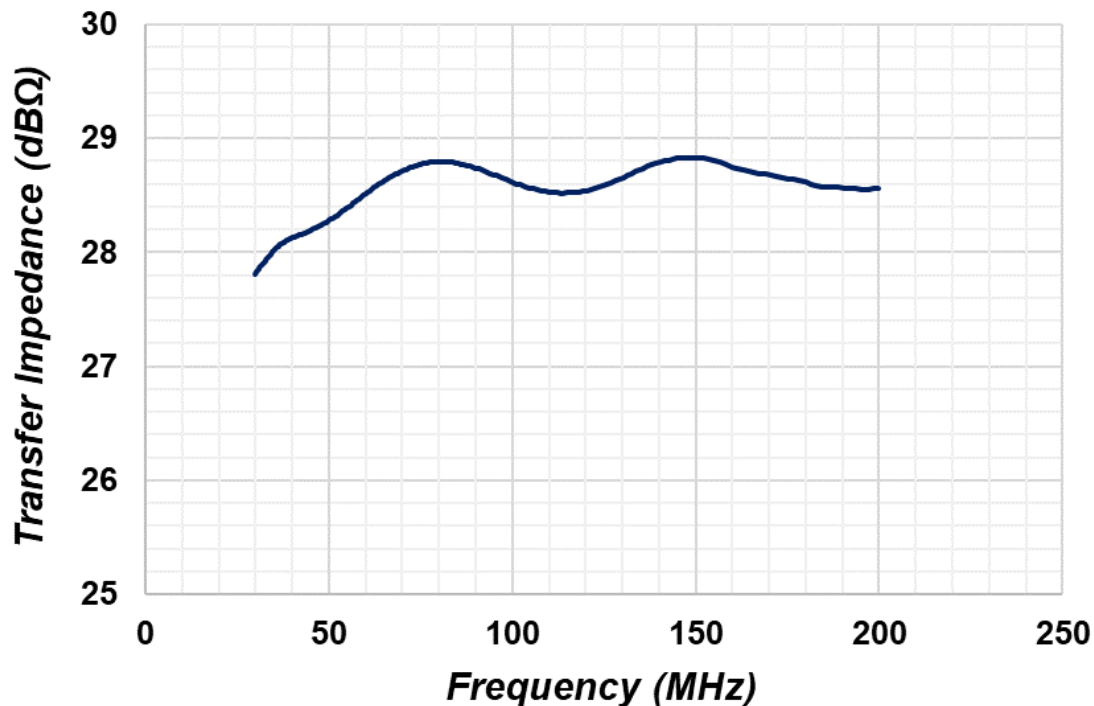

Figure 2.5-40. Nominal Transfer Impedance of CISPR 16 Absorbing Clamp

Check the GSFC Technical Standards Program website at <http://standards.gsfc.nasa.gov> or contact the Executive Secretary for the GSFC Technical Standards Program to verify that this is the correct version prior to use.

#### 2.5.3.3.2.1.2 Measurement System Integrity (MSI) Verification:

Prior to performing the BCE test, it is necessary to verify measurement system integrity (MSI). MSI is checked at a minimum of three frequencies. The MSI check is conducted according to the steps below:

- 1) Set up the equipment in the same manner as the calibration procedure above. Spectrum Analyzer #2 is replaced by the measurement receiver and any controller/automation used during the BCE test. The measurement receiver is installed as it would be during the BCE test, with all interconnecting cables between it and the clamp as per the test set-up.
- 2) Apply a calibrated signal level, which is at least 6 dB below the applicable limit, at 3 frequencies in the range of the low frequency current probe and 3 frequencies in the range of the absorbing clamp (30 MHz, 100 MHz, and 200 MHz).
- 3) Scan the measurement receiver for each frequency in the same manner as a normal data scan.
- 4) Verify that the signal level indicated by the measurement system is within +/- 3 dB of the actual current level. If readings are obtained which deviate by more than  $\pm 3$  dB, locate the source of the error and correct the deficiency prior to proceeding with the testing.

#### 2.5.3.3.2.1.3 CMCE Testing

The test method from 150 kHz to 200 MHz requires the following test equipment:

- 1) Measurement receivers
- 2) Data recording device
- 3) Signal generators
- 4) Capacitor network consisting of two 10  $\mu$ F feedthrough capacitors and one 10,000  $\mu$ F capacitor (replacing the LISNs specified by SL-E-0002)
- 5) Absorbing clamp (per CISPR 16, Specification for radio disturbance and immunity measuring apparatus and methods)

Setup the test equipment as shown in Figure 2.5-8. Place the absorbing clamp around the cable, with the current probe side of the clamp as close as possible to the equipment under test but in no case more than 15 cm away from the EUT.

Scan the measurement receiver according to Table II of MIL-STD-461G. Take the voltage measured by the clamp (in dB $\mu$ V) minus the transfer impedance at that frequency (in dB $\Omega$ ) to determine the current level (in dB $\mu$ A). Compare this to the Common Mode Conducted Emissions limit. This may be the limit shown in Figure 2.5-7 or the tailored limit defined in order to protect potentially sensitive victim cables.

### 2.5.3.3.2.2 CMCE and Radiated Electric Fields

Figure 2.5-41 shows the electric and magnetic fields generated at a distance  $r$  from an elemental electric (Hertzian) dipole model of infinitesimal length  $dl$ . The electric field components are as follows:

$$E_r = 2 \frac{Idl}{4\pi} \eta_0 \beta_0^2 \cos \theta \left( \frac{1}{\beta_0^2 r^2} - j \frac{1}{\beta_0^3 r^3} \right) e^{-j\beta_0 r}$$

$$E_\theta = \frac{Idl}{4\pi} \eta_0 \beta_0^2 \sin \theta \left( j \frac{1}{\beta_0 r} + \frac{1}{\beta_0^2 r^2} - j \frac{1}{\beta_0^3 r^3} \right) e^{-j\beta_0 r}$$

$$E_\phi = 0$$

When making radiated electric field measurements, it is generally assumed (with varying degrees of accuracy) that the measurement antenna is in the far field. In this case, the  $1/(\beta r)$  terms dominate and the  $1/(\beta r)^2$  and  $1/(\beta r)^3$  terms go to 0. Thus,  $E_r$  goes to 0 and we are left with:

$$E_{far} = j \frac{Idl}{4\pi} \eta_0 \beta_0 \sin \theta \frac{e^{-j\beta_0 r}}{r} \vec{a}_\theta$$

For constant  $\beta$ ,  $r$ , and  $\theta$ , the above can be simplified as:

$$|E_{far}| = CONSTANT \cdot Idl$$

The total electric field at a distance  $r$  from the center of a wire of length  $l$  would be given by the integrated sum of the individual current contributions at each position  $z$  along the wire:

$$|E_{far}| = CONSTANT \cdot \int_0^l I(z) dz$$

Multiplying by  $l$  gives:

$$|E_{far}| = CONSTANT \cdot l \cdot \frac{1}{l} \int_0^l I(z) dz$$

The last term in the expression above is the very definition of integrated average current:

$$I_{AV} = \frac{1}{l} \int_0^l I(z) dz$$

Thus, the radiated electric field is determined by the net integrated average current on the cable and not by the peak current.

Implications of net integrated average current on CMCE measurements are discussed in section 2.5.3.3.2.4.

Further details are provided in the GEVS application note entitled, "Radiated Emissions as a Function of Common Mode Current."

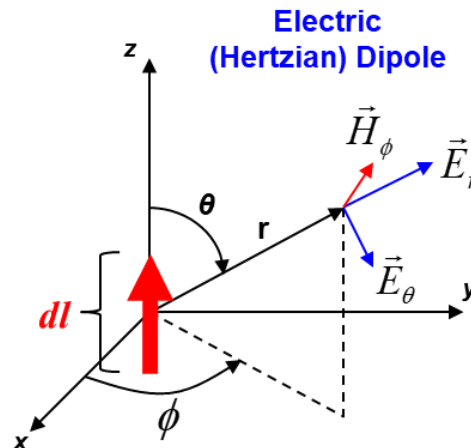

**Figure 2.5-41. Elemental Electric (Hertzian) Dipole Model**

#### 2.5.3.3.2.3 CMCE and Crosstalk

Figure 2.5-42 shows a simplified inductive crosstalk model. The culprit cable carries a common mode current as a function of position,  $I(z)$ , as shown. To first order, the B-field coupling to the victim cable at position  $z$  will be proportional to the current at the corresponding position on the culprit cable:

$$B(z) = \frac{\mu_0}{2\pi r} I(z)$$

The coupled potential in the victim cable is the time derivative of the total magnetic flux  $\Phi$  coupling through the loop formed by the victim cable over the ground plane. For frequencies at which the cable is electrically short, the current is constant over the length of the culprit cable, which means that, to first order, that the B-field is constant over the length of the victim cable. In this case,  $\Phi = BA$ , where  $A$  is the area of the victim loop given by the length  $l$  of the wire multiplied by the height  $h$  above the ground plane.

For frequencies at which the cable is electrically long,  $\Phi$  is the spatial integral of  $B(z)$  over the length of the cable:

$$\Phi = h \int_0^l B(z) dz = \frac{\mu_0 h}{2\pi r} \int_0^l I(z) dz$$

where  $I(z)$  includes magnitude and phase at each position. Multiplying both numerator and denominator by  $l$  gives:

$$\Phi = h \int_0^l B(z) dz = \frac{\mu_0 h l}{2\pi r} \cdot \frac{1}{l} \int_0^l I(z) dz$$

The last term in the expression above is the very definition of integrated average current:

$$I_{AV} = \frac{1}{l} \int_0^l I(z) dz$$

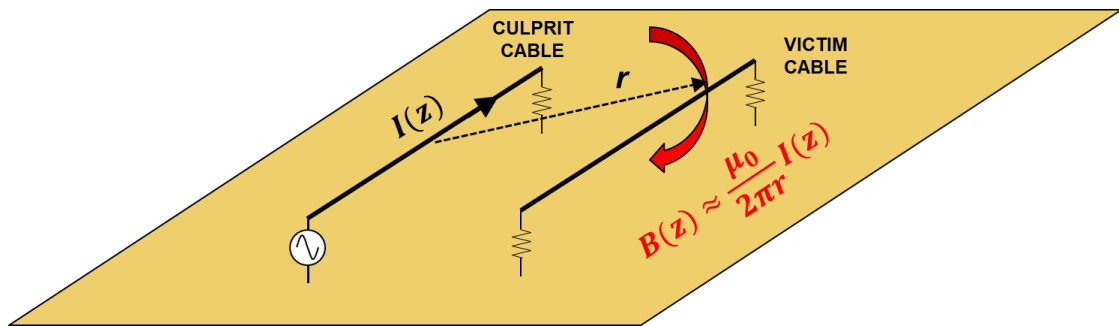

**Figure 2.5-42. Simplified Inductive Crosstalk Model**

Just as with radiated electric fields discussed in the previous section, crosstalk is determined by the net integrated average current on the culprit cable and not by the peak current.

Implications of net integrated average current on CMCE measurements are discussed in section 2.5.3.3.2.4.

Further details are provided in the GEVS application note entitled, “Inductive Crosstalk at the System Level.”

#### 2.5.3.3.2.4 Current Distribution on Mismatched Transmission Line

When considering common mode conducted emissions on a cable, the cable must be considered a wire-above-ground transmission line, the pertinent parameters of which are discussed in section 2.5.3.3.9.

In most cases, the characteristic impedance  $Z_0$  falls in the range of 200 – 300  $\Omega$ . A value of 300  $\Omega$  will be used herein as a case study.

The general case for CMCE measurements is that of a shielded cable with the shield terminated to chassis on both ends of the cable. The wire-above-ground transmission line will not be terminated in its characteristic impedance (the terminating impedance on each end will be near 0  $\Omega$ ), which will result in reflections on each end and standing waves along the length of the cable. This behavior must be understood in order to assess their implications for performing CMCE measurements.

The general transmission line model is shown in Figure 2.5-43.

The reflection coefficients at the source and load ends,  $\Gamma_S$  and  $\Gamma_L$ , respectively, are given by:

$$\Gamma_S = \frac{Z_S - Z_0}{Z_S + Z_0}$$

$$\Gamma_L = \frac{Z_L - Z_0}{Z_L + Z_0}$$

where  $Z_S$  and  $Z_L$  are the terminating impedances at the source and load ends, respectively.

Check the GSFC Technical Standards Program website at <http://standards.gsfc.nasa.gov> or contact the Executive Secretary for the GSFC Technical Standards Program to verify that this is the correct version prior to use.

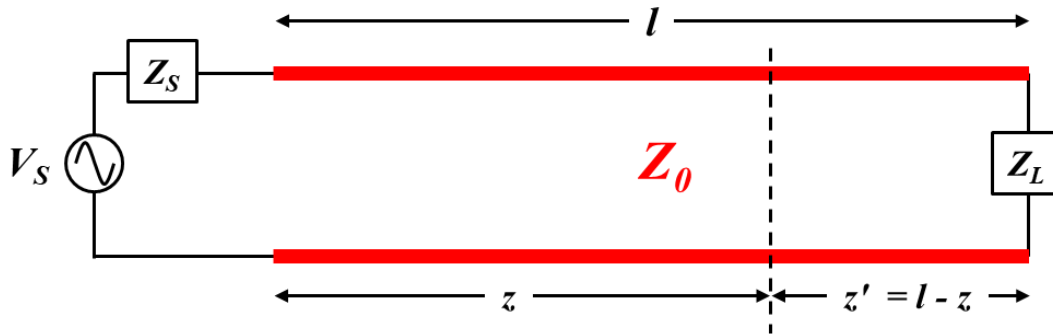

**Figure 2.5-43. General Transmission Line Model**

The envelope of the current amplitude on a mismatched transmission line of length  $l$  as a function of distance  $z$  from the source is given by:

$$I(z) = \frac{V_S}{Z_0 + Z_S} \cdot \frac{1 - \Gamma_L e^{-j2\beta l} e^{j2\beta z}}{1 - \Gamma_S \Gamma_L e^{-j2\beta l}}$$

where  $V_S$  is the amplitude of the source end drive potential.

Multiplying numerator and denominator by the denominator's complex conjugate gives:

$$I(z) = \frac{V_S}{Z_0 + Z_S} \cdot \frac{1 - \Gamma_L e^{-j2\beta l} e^{j2\beta z}}{1 - \Gamma_S \Gamma_L e^{-j2\beta l}} \cdot \frac{1 - \Gamma_S \Gamma_L e^{j2\beta l}}{1 - \Gamma_S \Gamma_L e^{j2\beta l}}$$

$$I(z) = \frac{V_S}{Z_0 + Z_S} \cdot \frac{1 + \Gamma_S \Gamma_L \Gamma_L e^{j2\beta z} - \Gamma_L e^{-j2\beta l} e^{j2\beta z} - \Gamma_S \Gamma_L e^{j2\beta l}}{(\Gamma_S \Gamma_L)^2 - 2\Gamma_S \Gamma_L \cos(2\beta l) + 1}$$

$$I(z) = \frac{V_S}{Z_0 + Z_S} \cdot \frac{1 + \Gamma_S \Gamma_L \Gamma_L e^{j2\beta z} - \Gamma_L e^{-j2\beta l} e^{j2\beta z} - \Gamma_S \Gamma_L e^{j2\beta l}}{(\Gamma_S \Gamma_L)^2 - 2\Gamma_S \Gamma_L \cos(2\beta l) + 1}$$

The numerator of the second term is split into its real and imaginary components as follows:

$$NUM_{Re} = 1 + \Gamma_S \Gamma_L^2 \cos(2\beta z) - \Gamma_L \cos(2\beta z - 2\beta l) - \Gamma_S \Gamma_L \cos(2\beta l)$$

$$NUM_{Im} = \Gamma_S \Gamma_L^2 \sin(2\beta z) - \Gamma_L \sin(2\beta z - 2\beta l) - \Gamma_S \Gamma_L \sin(2\beta l)$$

This leads to the following expressions for the magnitude and phase of the current amplitude as a function of position on the cable:

$$|I(z)| = \frac{V_S}{Z_0 + Z_S} \cdot \frac{\sqrt{(NUM_{Re})^2 + (NUM_{Im})^2}}{(\Gamma_S \Gamma_L)^2 - 2\Gamma_S \Gamma_L \cos(2\beta l) + 1}$$

$$\theta(z) = \tan^{-1} \frac{NUM_{Im}}{NUM_{Re}}$$

Figure 2.5-44 through Figure 2.5-47 show the relationship of current amplitude vs. position for a wire-above-ground transmission line with  $Z_0 = 300 \Omega$  and terminated with  $Z_S = Z_L = 1 \Omega$ . The plots are normalized for  $V_S = 2 \text{ V}$  to give a peak current of 1 ampere. These plots carry a number of implications for CMCE measurements as discussed below.

Check the GSFC Technical Standards Program website at <http://standards.gsfc.nasa.gov> or contact the Executive Secretary for the GSFC Technical Standards Program to verify that this is the correct version prior to use.

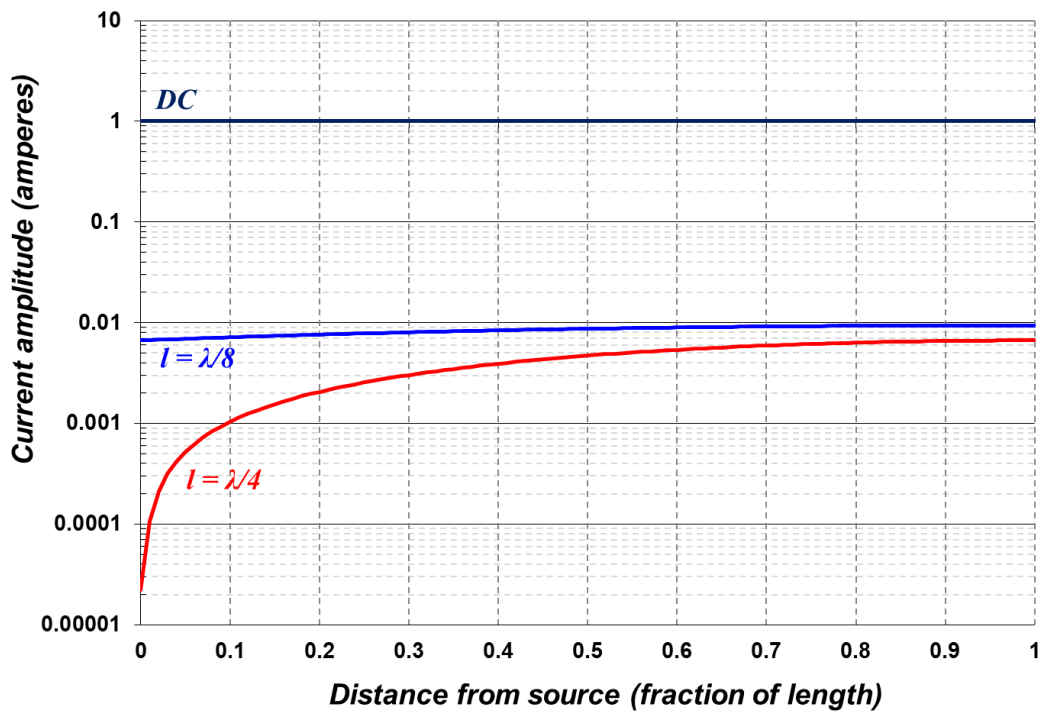

Figure 2.5-44. Current Amplitude vs. Position, DC to  $l = \lambda/4$

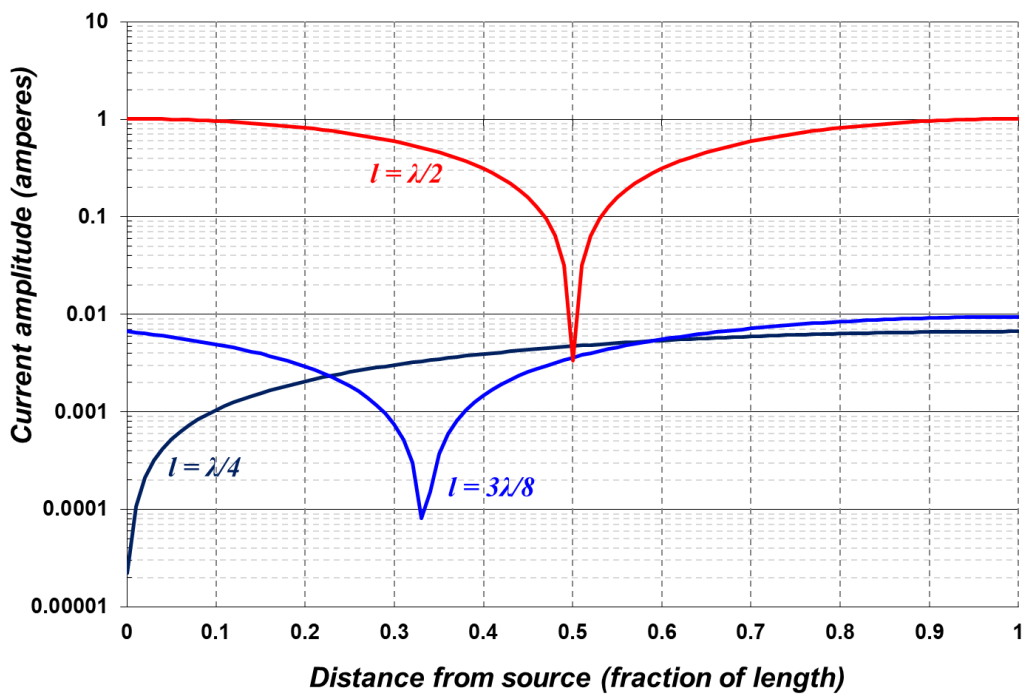

Figure 2.5-45. Current Amplitude vs. Position,  $l = \lambda/4$  to  $l = \lambda/2$

Check the GSFC Technical Standards Program website at <http://standards.gsfc.nasa.gov> or contact the Executive Secretary for the GSFC Technical Standards Program to verify that this is the correct version prior to use.

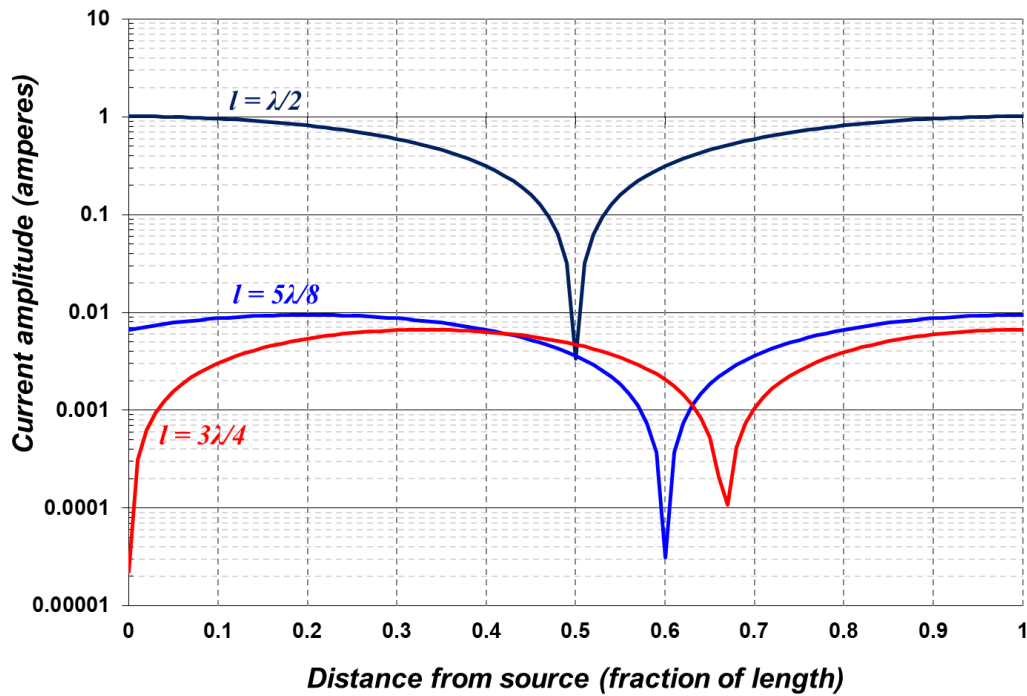

Figure 2.5-46. Current Amplitude vs. Position,  $l = \lambda/2$  to  $l = 3\lambda/4$

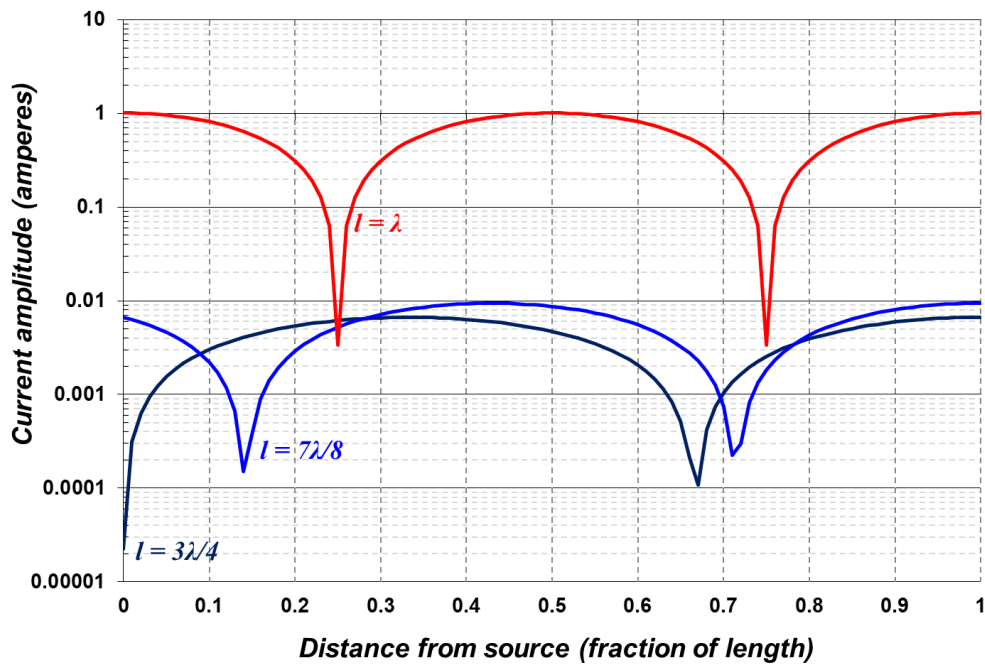

Figure 2.5-47. Current Amplitude vs. Position,  $l = 3\lambda/4$  to  $l = \lambda$

Check the GSFC Technical Standards Program website at <http://standards.gsfc.nasa.gov> or contact the Executive Secretary for the GSFC Technical Standards Program to verify that this is the correct version prior to use.

From DC through frequencies corresponding to approximately  $l = \lambda/8$ , the current amplitude is nearly constant over the entire length. (This is the very definition of “electrically short.”) At these frequencies, the placement of the current probe for a CMCE measurement is not crucial; it may be placed anywhere along the length of the cable. For  $l > \lambda/8$ , the current amplitude is no longer constant over the cable length, and the location of the current probe for a CMCE measurement becomes important. (This is the very definition of “electrically long.”)

At  $l = \lambda/4$ , the current is a minimum at the source and a maximum at the load. The current at the source end may be several orders of magnitude lower than that at the load.

For  $\lambda/4 \leq l \leq \lambda$ , there is at least one current null along the length of the cable with a much lower amplitude than the peak. These nulls occur at distances from the load end equal to odd multiples of  $\lambda/4$ . The ratio of the maximum to minimum amplitude, called the standing wave ratio (SWR), may span several orders of magnitude.

For  $l = \lambda/2$  and  $l = \lambda$ , the maximum current amplitude is equal to the DC current. These are resonant frequencies, which are discussed further below. Note that even in these cases, nulls occur on the line at distances of odd multiples of  $(2n-1)\lambda/4$  from the load end.

At all frequencies, a current maximum occurs at the load end.

Figure 2.5-48 shows the source end ( $z = 0$ ) current amplitude as a function of  $l/\lambda$  for the same configuration described above. At low frequencies for which the length is much shorter than a wavelength the source end current is equal to the DC current of 1 A (120 dB $\mu$ A). For  $l/\lambda > 0.001$ , the amplitude drops due to the standing waves that develop on the mismatched transmission line according to the equation above. As shown in the figure, the source end current reaches a minimum (null) when  $l = \lambda/4$  and a maximum (peak) when  $l = \lambda/2$ , and it repeats this pattern for odd multiples of  $\lambda/4$  and even multiples of  $\lambda/2$ .

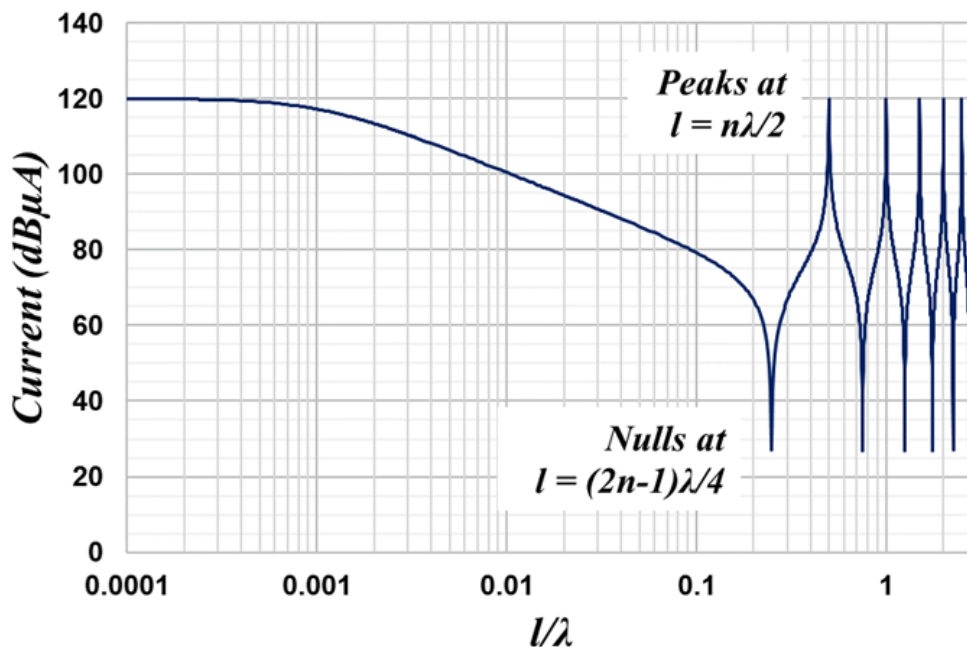

Figure 2.5-48. Source End Current vs.  $l/\lambda$  for Mismatched Transmission Line

Figure 2.5-49 shows the currents at the midpoint and at the load end of the mismatched transmission line in comparison with the source end current. At frequencies for which  $l < \lambda/10$ , the current is essentially uniform along the length. Thus, at these frequencies, the placement of the current probe for a CMCE measurement is not crucial; it may be placed anywhere along the length of the cable.

At frequencies for which  $l > \lambda/10$ , the measured current clearly depends very significantly on probe position. Placing the current probe in a single location adjacent to the EUT (i.e. at the source end) may result in an artificially high level at resonant peaks for which  $l = n\lambda/2$  or an artificially low level at nulls for which  $l = (2n-1)\lambda/4$ . In the former case, this could cause an apparent test failure for a level that may be benign with the different cable layout in the flight configuration. In the latter case, it could mask a real emission from the EUT that could be more significant in the flight configuration.

As Figure 2.5-45 shows, the maximum current may be captured at all frequencies by placing the current probe at the load end. While this approach addresses the nulls at  $l = (2n-1)\lambda/4$ , it will still produce artificially high levels for the peaks at  $l = n\lambda/2$ .

The significance of this is that the pattern of peaks and nulls depends directly on cable length and routing (height above ground plane, etc.). Unless the test cabling configuration precisely replicates the flight configuration (which may be difficult to do; for example, the specific flight cable lengths may not be defined at the time of a unit level test), the pattern of peaks and nulls will be different between the two configurations, and the test results may not be directly applicable to the flight configuration. Moreover, as discussed in sections 2.5.3.3.2.2 and 2.5.3.3.2.3, the dominant factor is the net integrated average current along the wire, not the peaks and nulls.

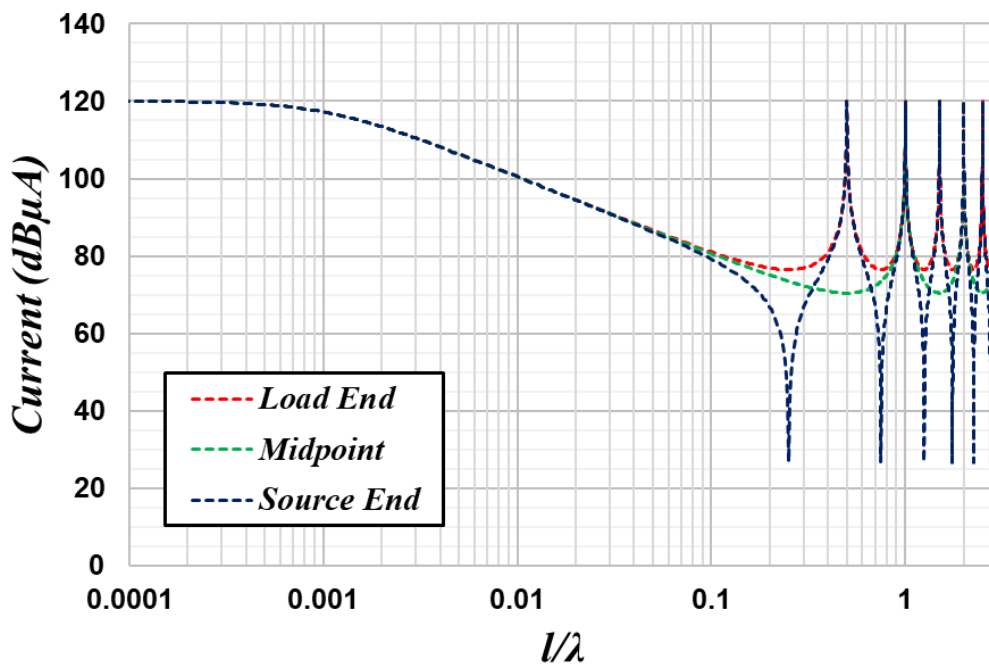

Figure 2.5-49. Currents at Various Locations on Mismatched Transmission Line

Ideally, what is desired is a normalized measurement of the emissions from the EUT that is independent of the cable configuration. This will provide a truer assessment of the frequency content of the emissions from the EUT that may be more effectively use to assess compatibility with the rest of the platform in the flight configuration.

The resonant behavior is determined in large part by the transmission line's input impedance  $Z_i$ , which is given by:

$$Z_i = Z_0 \frac{Z_L + jZ_0 \tan(\beta l)}{Z_0 + jZ_L \tan(\beta l)}$$

When  $l$  is an odd multiple of  $\lambda/4$ , the  $\tan(\beta l)$  terms dominate and the expression reduces to:

$$Z_i = \frac{Z_0^2}{Z_L}$$

when  $l = (2n-1)\lambda/4$ , a shorted termination will map to an open circuit at the source end, producing the current nulls as shown in Figure 2.5-49.

When  $l$  is a multiple of  $\lambda/2$ , the  $\tan(\beta l)$  terms go to 0 and the expression reduces to:

$$Z_i = Z_L$$

Thus, when  $l = n\lambda/2$ , a shorted termination will map to a short circuit at the source end, producing the current peaks as shown in Figure 2.5-49.

By inserting a controlled resistance into the line in order to increase the effective  $Z_L$  in the frequency range where the peaks and nulls occur, the input impedance will decrease at the nulls and increase at the peaks. This will provide damping of the peaks and nulls in order to provide the normalized measurement of EUT emissions described above.

Figure 2.5-50 shows the effect of damping on the first null at  $l = \lambda/4$ . The added impedance increases the minimum current at the source end while leaving the maximum current unchanged. When the load impedance matches  $Z_0$ , the current amplitude is constant across the length of the cable. Moreover, at all values of damping impedance, the maximum current is equal to the current for a properly matched terminating impedance of  $Z_0$ . The implication is that at null frequencies, the damping impedance has no effect on the maximum current on the cable, and it provides the benefit of making the current more uniform along its length. Thus, the specific position of the current probe for a CMCE measurement is no longer crucial.

Figure 2.5-51 shows the effect of damping on the first resonant peak at  $l = \lambda/2$ . The added impedance decreases the maximum current at the source and load ends. When the load impedance matches  $Z_0$ , the current amplitude is constant across the length of the cable. At all values of damping impedance, the peak current at the midpoint of the cable ( $\lambda/4$  from the load end) is equal to the ideal current for a properly matched terminating impedance of  $Z_0$ . As was the case described above for null frequencies, damping provides the benefit of making the current more uniform along its length. Thus, the specific position of the current probe for a CMCE measurement is no longer crucial.

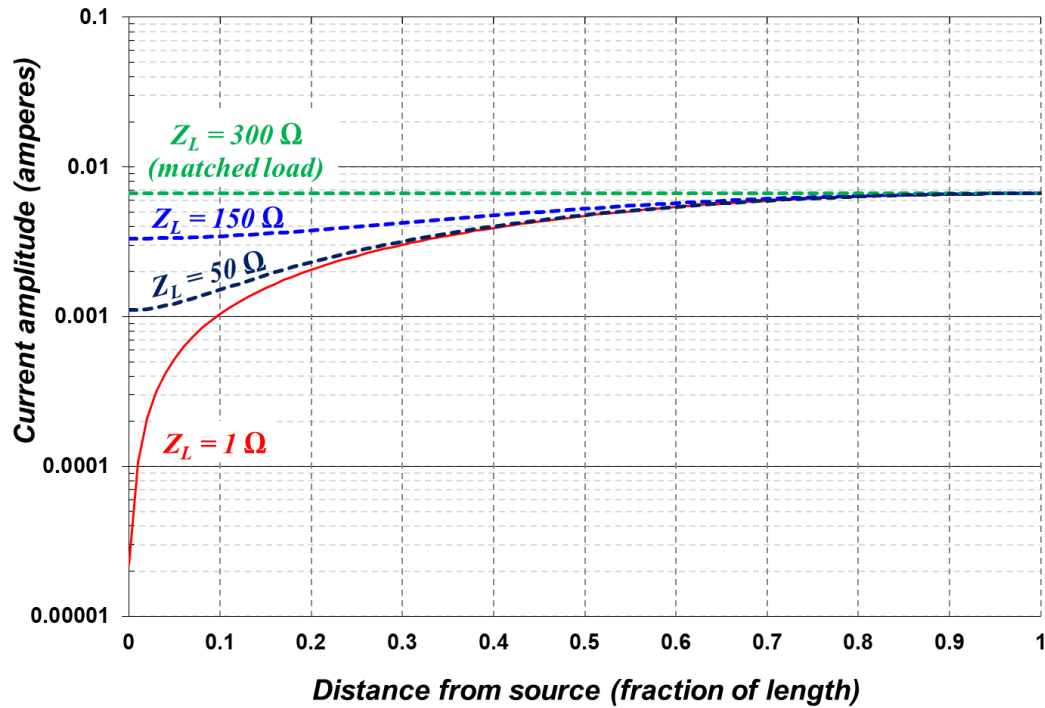

Figure 2.5-50. Effect of Damping Impedance on Null at  $l = \lambda/4$

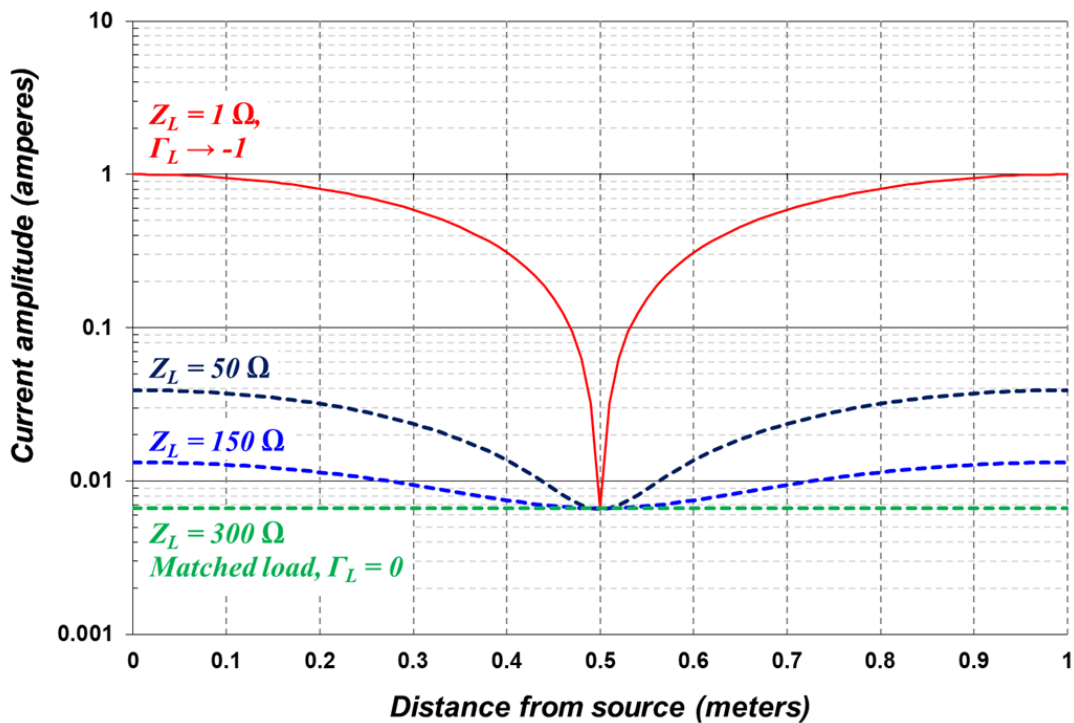

Figure 2.5-51. Effect of Damping Impedance on Peak at  $l = \lambda/2$

Check the GSFC Technical Standards Program website at <http://standards.gsfc.nasa.gov> or contact the Executive Secretary for the GSFC Technical Standards Program to verify that this is the correct version prior to use.

In order to more fully address the effect of damping on the resonant peaks for which  $l = n\lambda/2$ , it is instructive to return to the full time-domain representation of the current distribution along the wire, which is as follows using the expressions previously derived for magnitude and phase.

$$I(z, t) = |I(z)|e^{j\theta(z)} \cdot e^{j(\omega t - \beta z)}$$

Taking the real part:

$$I(z, t) = |I(z)| \cdot \cos[\omega t - \beta z + \theta(z)]$$

The primary reason for performing CMCE measurements is to evaluate the risk of radiated emissions and crosstalk. As discussed in sections 2.5.3.3.2.2 and 2.5.3.3.2.3, the dominant factor for both of these concerns is the net integrated average current along the wire:

$$I_{AV} = \frac{1}{l} \int_0^l I(z) dz$$

When the wire is driven at the frequency for which  $l = \lambda/2$ , the current distribution  $I(z)$  will be exactly half a sinusoid with a phase shift that changes as a function of time. Figure 2.5-52 shows the “snapshot in time” for which  $I(z)$  is precisely symmetric about 0, giving an average current of exactly 0. To first order, the resulting magnetic flux density  $B(z, t)$  at this “snapshot in time” is also symmetric about 0, giving a net coupled magnetic flux of exactly 0.

Figure 2.5-53 shows the “snapshot in time” for which  $I(z)$  is entirely “positive” (on the same side of the 0 line). This results in the maximum net coupled flux through the victim loop as shown.

As shown in Figure 2.5-54, increased damping reduces the peak amplitude of  $I(z)$  at the “snapshot” in time when the average current and net coupled magnetic flux are 0. As shown in Figure 2.5-55, the current distribution at the “snapshot in time” corresponding to maximum coupling is independent of the damping impedance.

Moreover, the average current at frequencies for which  $l = n\lambda/2$  is independent of the damping impedance (see derivation at the end of this subsection):

$$Re[I_{AV}(t)] = \frac{V_S}{Z_0} \cdot \frac{2}{n\pi} \cdot \sin n\omega_0 t$$

where  $n$  is an integral multiple of  $\lambda/2$  and  $\omega_0$  is the temporal frequency for which  $l = \lambda/2$ .

Thus, at resonant peaks for which  $l = n\lambda/2$ , damping provides the benefit of making the current more uniform along its length of the wire without changing the average current, which is the primary parameter of interest.

**“Snapshot in time”:**

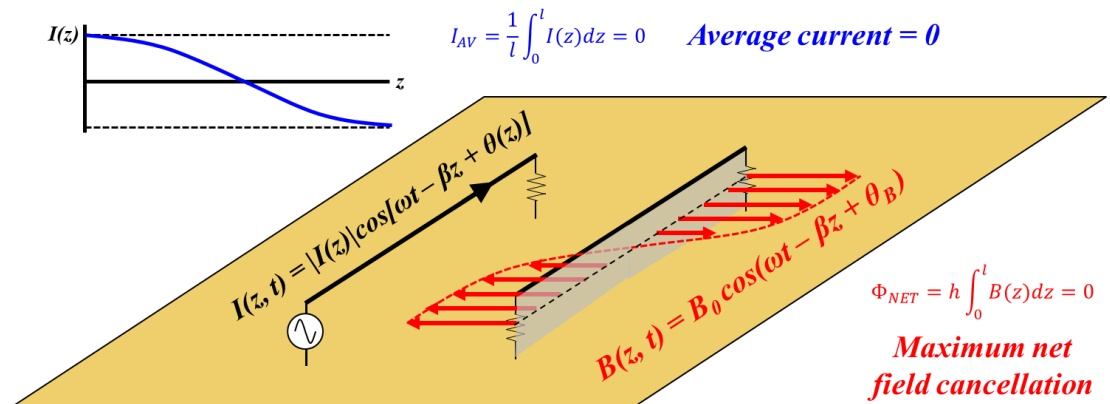

Figure 2.5-52. “Snapshot in Time” for Maximum Field Cancellation

**“Snapshot in time”:**

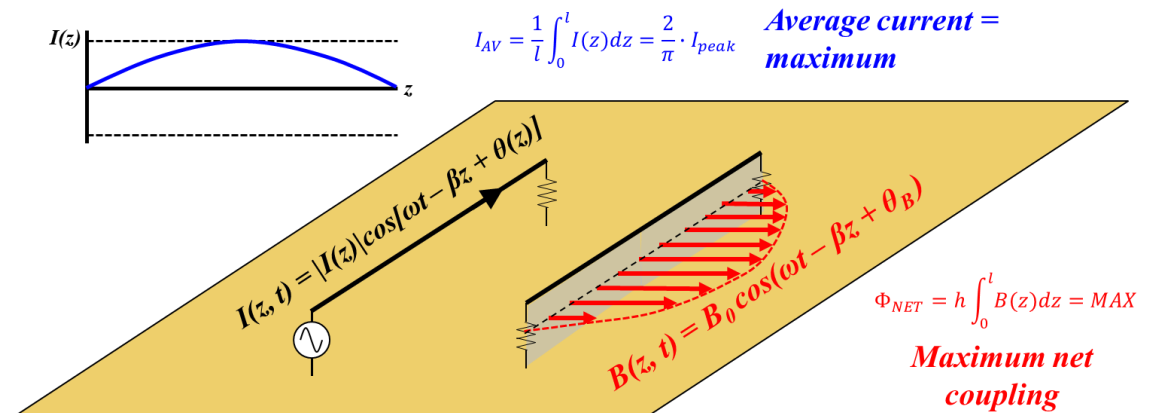

Figure 2.5-53. “Snapshot in Time” for Maximum Coupling

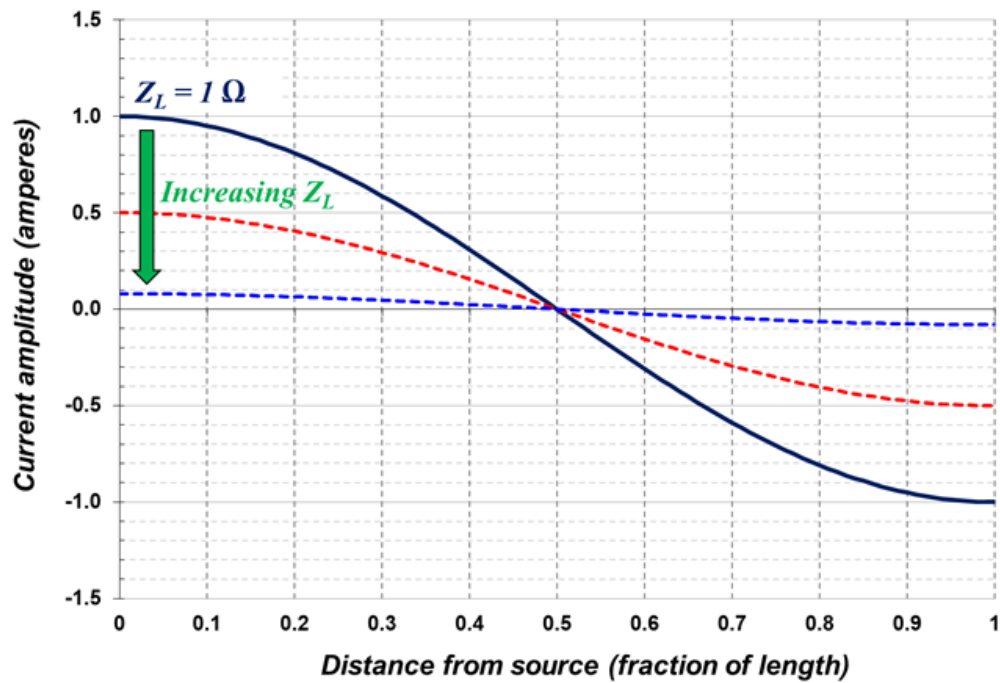

Figure 2.5-54. Damping at “Snapshot in Time” for Maximum Field Cancellation

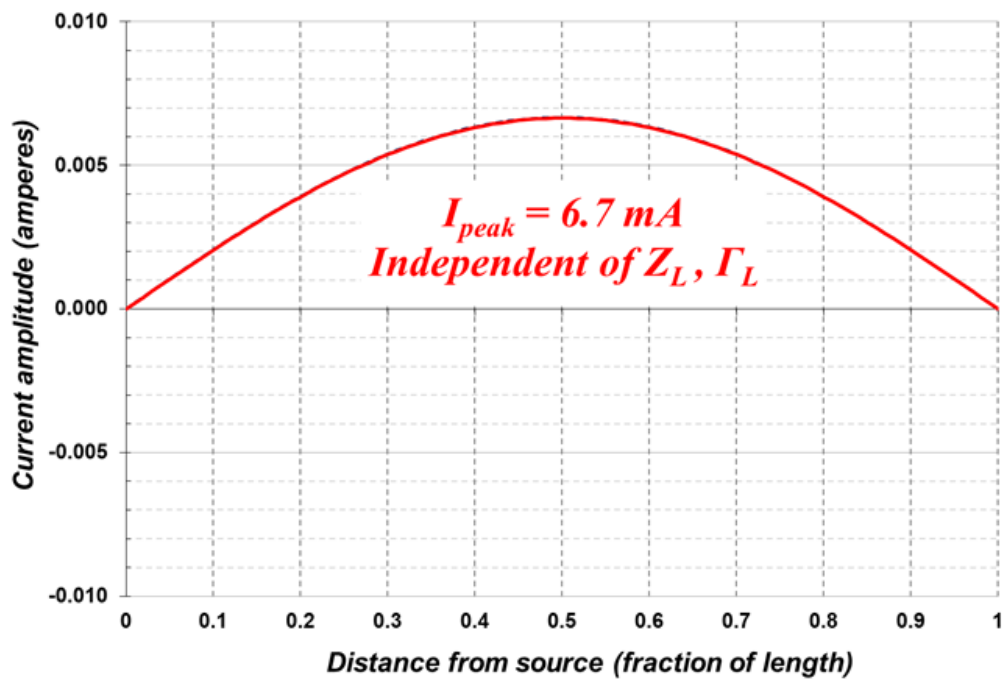

Figure 2.5-55. Damping at “Snapshot in Time” for Maximum Coupling

Check the GSFC Technical Standards Program website at <http://standards.gsfc.nasa.gov> or contact the Executive Secretary for the GSFC Technical Standards Program to verify that this is the correct version prior to use.

Thus, inserting a damping resistance in the cable would effectively “detune” the resonant peaks without changing the average current, and it would come closer to providing the ideal normalized measurement of EUT emissions that is desired. The ideal would be to provide a matched termination equal to the transmission line’s characteristic impedance. However, a matched termination at all frequencies would significantly reduce the current emissions at frequencies for which the cable is electrically short, which is not desirable. Moreover, such a connection would require breaking the shield termination and inserting a 300  $\Omega$  resistor, which is neither desirable nor practical.

What is desired is a means of inserting a damping resistance in the line at frequencies for which the cable is electrically long that will dampen the peaks and nulls shown in Figure 2.5-48. This function is provided by the absorbing clamp which inserts the desired damping impedance, Thus, minimizing the standing waves on an electrically long mismatched transmission line and facilitating the normalized measurement of EUT emissions at higher frequencies.

The resulting coupling onto victim cables is addressed in section 2.5.3.3.6.1 for Common Mode Conducted Susceptibility (CS114 test method).

Derivation of average current for  $l = n\lambda/2$ :

$$I(z, t) = \frac{V_S}{Z_0 + Z_S} \cdot \frac{1 - \Gamma_L e^{j2\beta z}}{1 - \Gamma_S \Gamma_L} e^{j(\omega t - \beta z)} = \frac{V_S}{Z_0 + Z_S} \cdot \frac{e^{j\omega t}}{1 - \Gamma_S \Gamma_L} (e^{-j\beta z} - \Gamma_L e^{j\beta z})$$

For  $Z_S \rightarrow 0$ ,  $\Gamma_S \rightarrow -1$ :

$$I(z, t) = \frac{V_S}{Z_0} \cdot \frac{e^{j\omega t}}{1 + \Gamma_L} (e^{-j\beta z} - \Gamma_L e^{j\beta z})$$

$$\begin{aligned} I_{AV}(t) &= \frac{V_S}{Z_0 + Z_S} \cdot \frac{e^{j\omega t}}{1 + \Gamma_L} \cdot \frac{1}{l} \int_0^l (e^{-j\beta z} - \Gamma_L e^{j\beta z}) dz = \frac{V_S}{Z_0 + Z_S} \cdot \frac{e^{j\omega t}}{1 + \Gamma_L} \cdot \frac{1}{j\beta l} \cdot [-e^{-j\beta z} - \Gamma_L e^{j\beta z}]_0^l \\ &= \frac{V_S}{Z_0} \cdot \frac{e^{j\omega t}}{1 + \Gamma_L} \cdot \frac{1}{j\beta l} \cdot [-e^{-j\beta l} - \Gamma_L e^{j\beta l} + 1 + \Gamma_L] \end{aligned}$$

For  $\beta = 2\pi/\lambda$  and  $l = n\lambda/2$ ,  $\beta l = n\pi$ , and  $\omega = n\omega_0$ , where  $\omega_0$  is the frequency for which  $l = \lambda/2$ .

For even  $n$ ,  $e^{jn\pi} = 1$  and  $I_{AV}(t) = 0$ .

For odd  $n$ ,  $e^{jn\pi} = -1$ , and:

$$\begin{aligned} I_{AV}(t) &= \frac{V_S}{Z_0} \cdot \frac{e^{jn\omega_0 t}}{1 + \Gamma_L} \cdot \frac{1}{jn\pi} \cdot [1 + \Gamma_L + 1 + \Gamma_L] \\ &= \frac{V_S}{Z_0} \cdot \frac{e^{jn\omega_0 t}}{1 + \Gamma_L} \cdot \frac{2}{jn\pi} \cdot [1 + \Gamma_L] \\ &= \frac{V_S}{Z_0} \cdot \frac{2}{n\pi} \cdot \frac{1 + \Gamma_L}{1 + \Gamma_L} \cdot [-je^{jn\omega_0 t}] \end{aligned}$$

Dependence on  $\Gamma_L$  cancels, leaving the following expression for average current at  $l = n\lambda/2$  that is independent of  $Z_L$  and  $\Gamma_L$  and is always equal to the average current into a properly matched transmission line as determined by its characteristic impedance  $Z_0$ :

$$\text{Re}[I_{AV}(t)] = \frac{V_S}{Z_0} \cdot \frac{2}{n\pi} \cdot \sin n\omega_0 t$$

### 2.5.3.3.2.5 Example Current Measurements

Some example current measurements were performed using the wire-above-ground fixture depicted in Figure 2.5-56. The wire length was 4 meters to represent the length of a typical signal cable running from the EUT to the feedthrough panel. The load end was terminated in a short circuit, and the source end was driven by a 50  $\Omega$  signal source set to an output level of 0 dBm (224 mVrms) and swept from 30 MHz to 200 MHz.

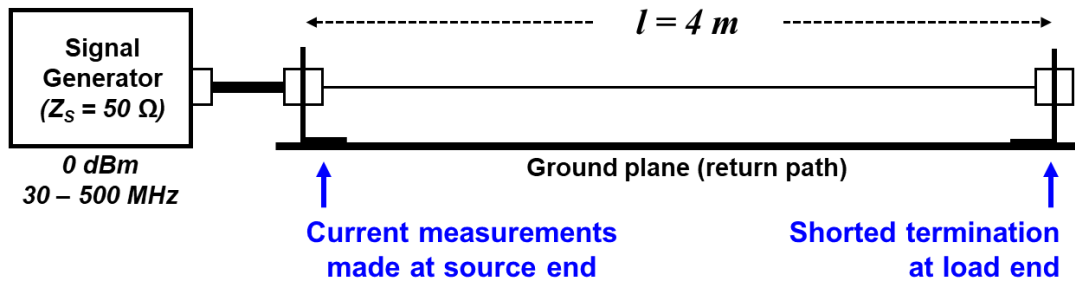

Figure 2.5-56. Current Measurement Fixture

Figure 2.5-57 shows the resulting current on the 4-meter wire measured from 150 kHz to 500 MHz with a standard current probe (Fischer F-65) at the source end, at the midpoint, and at the load end. These measured values show excellent agreement with the theoretical predictions shown in Figure 2.5-49. At the source end, nulls occur at odd multiples of 17 MHz (approximately  $\lambda/4$ ) and peaks occur at multiples of 34 MHz (approximately  $\lambda/2$ ). For the CMCE measurements using a standard current probe up to 30 MHz, placing the current probe near the load end (near the access panel in the actual setup) will effectively address the first null in most cases.

As discussed in section 2.5.3.2.1, all outer shields of all EGSE cables should be terminated at the chamber wall in order to prevent common mode currents from EGSE from entering the test chamber and increasing the ambient electromagnetic level. If the nature of specific EGSE cables renders this approach undesirable or, the cables should be run through a stuffing tube with the outer jacket removed and the tube filled with conductive wool as shown in Figure 2.5-33.

Figure 2.5-58 shows the current measured from 30 MHz to 200 MHz with two different absorbing clamps, the Fischer F-201-23mm and the Rohde & Schwarz MDS-21, compared with the current measured with the F-65 current probe. The results are plotted on a linear frequency scale in order to show the repeating pattern of peaks and nulls more clearly than on a logarithmic frequency scale.

Both absorbing clamps give very similar results. The peaks and nulls are smoothed out and it more closely resembles the ideal current into a matched load, by design. Thus, the absorbing clamp provides something much closer to the desired normalized measurement of emissions from the EUT that is independent of cable configuration in the frequency range that will contain resonant peaks and nulls.

The absorbing clamp is most effective for longer cables. In particular, it should be used for the 2-meter primary power cables and the signal cables connecting to the access panel. If CMCE measurements are desired on shorter cables connecting between different portions of the EUT (e.g. a setup that includes multiple electronics boxes with cables connecting between them), the absorbing clamp is less effective and a standard current probe should be used. Indeed, in many cases, the layout of such cables may not allow sufficient room for the absorbing clamp. As discussed above, the current probe should be placed at the load end (opposite to the signal source) in order to capture the peak current at all frequencies. If signal sources are connected at both ends of the cable, measurements should be taken at both ends.

If the total length of any cable is significantly longer than 4 meters, especially any cable that does not have its shield terminated at the access panel, it may be desirable to extend the lower frequency limit of the absorbing clamp measurements down to 10 MHz.

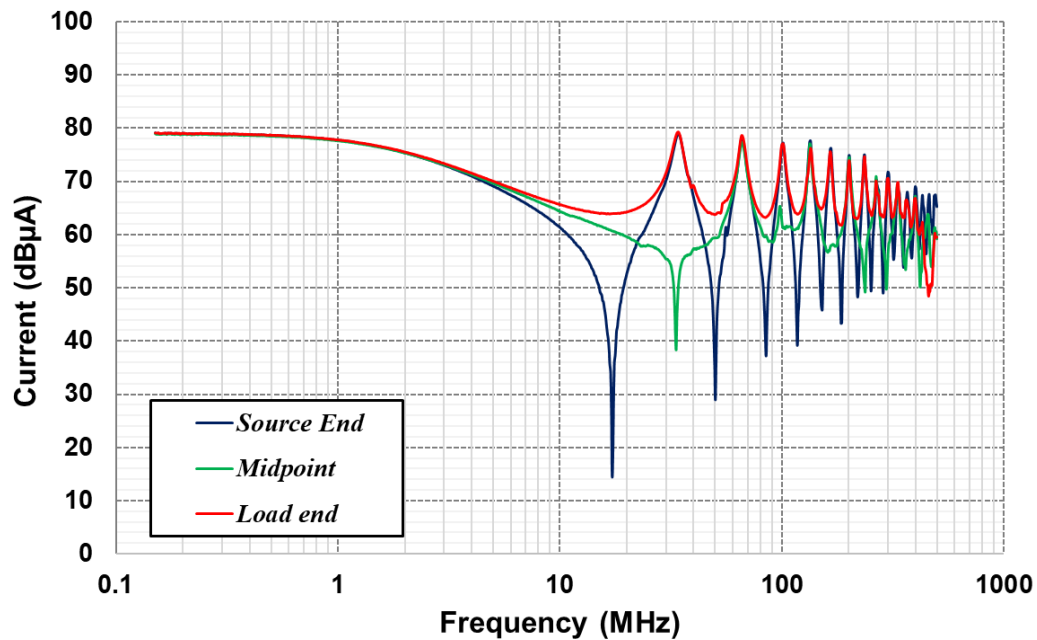

Figure 2.5-57. Measured Current with Standard Current Probe

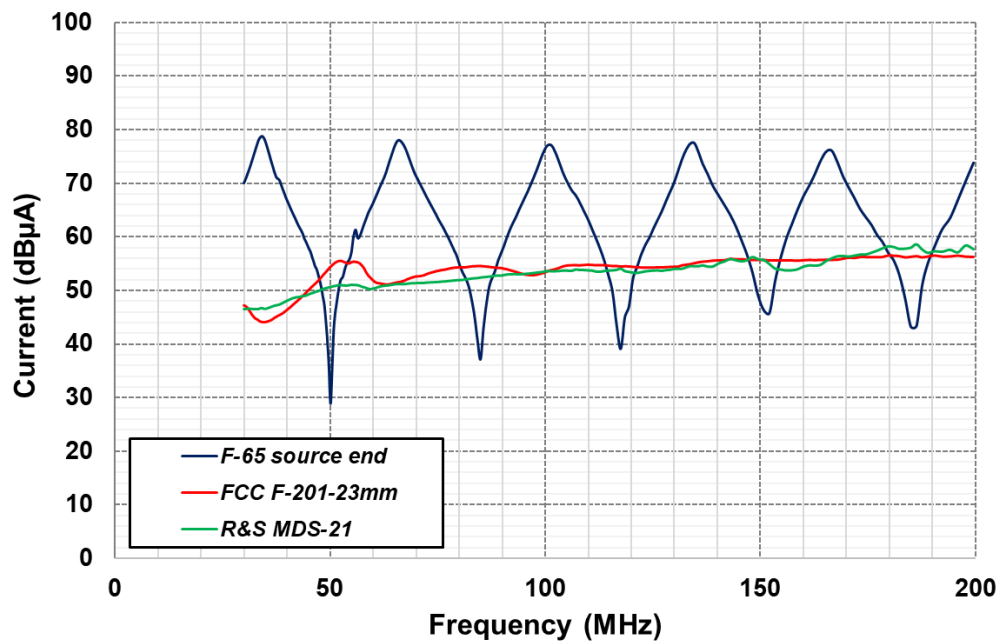

Figure 2.5-58. Example Measured Currents With and Without Absorbing Clamp

Check the GSFC Technical Standards Program website at <http://standards.gsfc.nasa.gov> or contact the Executive Secretary for the GSFC Technical Standards Program to verify that this is the correct version prior to use.

### 2.5.3.3.3 Conducted Emissions, Time Domain, Transients

As stated in Section 2.5.2.1.3, one of the primary purposes of this requirement is to ensure that equipment inrush current due to turn-on and operational transients will not overstress its circuit protection device (e.g. fuse).

The spacecraft provider will allocate a size/value for each circuit protection device based on the peak power allocation of its corresponding unit. The intent of this requirement is to ensure that the unit's inrush transient is within the allowable envelope for the given circuit protection device. Thus, minimizing the likelihood of tripping the device during integration or during flight operations.

The envelope shown in Section 2.5.2.1.3 is a specific example based on the FM12 style fuse used on many platforms. This envelope must be compared against the characteristics of the specific circuit protection device(s) used on the platform and tailored as necessary.

Although Figure 2.5-9 shows the current probe located between the capacitor network and the switch, probe placement is not critical. The 2 m power cables are not a significant fraction of a wavelength at the frequencies of interest in this measurement (see Section 2.5.3.2.3 for the relationship between frequency and wavelength). At the upper frequency of 1 MHz indicated above,  $\lambda = 300$  meters. Even if a probe is used with flat response up to 10 MHz (giving a resolution of approximately 0.1 microsecond),  $\lambda = 30$  meters at this frequency. In either case, 2 m power cables are less than  $\lambda/10$  for all frequencies of interest, and the measurement will not be significantly affected by probe placement.

The test equipment required is as follows:

- 1) Storage/holdup capacitors: 10,000  $\mu$ F or ten times the hold-up cap in the test sample, whichever is larger
- 2) Oscilloscope (floated ground if small value series resistor is used)
- 3) Solid-state switch that closely simulates the characteristics of the switching device used on the platform (example design shown in Figure 2.5-59)
- 4) One of the following current measurement devices:
  - a. Current probe with flat transfer impedance from 20 Hz to 1 MHz and minimum sensitivity of -40 dB $\Omega$
  - b. 10 m $\Omega$  resistor sized to handle steady-state test sample current

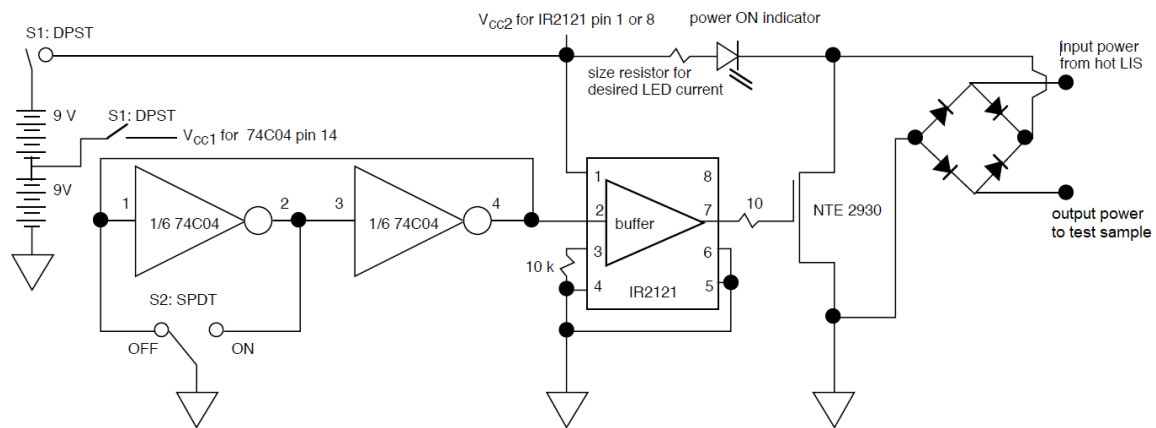

Note 1: CAUTION: Vcc potentials referenced to switched power potential, absolute Vcc potential is either 9 Volts or 18 Volts added to switched bus potential  
 Note 2: All resistor values in Ohms, all nominal

**Figure 2.5-59. Solid State Switch Example Design**

Measurement System Check procedure:

- 1) Configure the test setup for the measurement system check as shown in Figure 2.5-60 if using the current probe method or Figure 2.5-61 if using the series resistor method. Ensure that the power switch is turned off (open). If using a current probe, it must be oriented for a positive reading for the inrush current event. If using a resistor, the oscilloscope leads must be connected so that the potential drop across the resistor during the inrush event gives a positive reading.
- 2) Set up the oscilloscope as follows:
  - a. DC coupling
  - b. 5 mV/division sensitivity for resistor method; for current probe method, set sensitivity as appropriate for probe's transfer impedance
  - c. 50  $\mu$ s per division time base
  - d. Single sweep after trigger, with hold
  - e. Display delay such that leading edge of waveform is one division right of the left side of display grid
  - f. Trigger:
    - level set to 10 mV for resistor method; for current probe method, set level as appropriate for probe's transfer impedance
    - positive (rising) edge
- 3) Turn on the measurement equipment and allow a sufficient time for stabilization.
- 4) Energize switch and record waveform. Compare trace to the current profile shown in Figure 2.5-62. If the current probe method is used, the displayed voltage must be converted to current using the current probe transfer impedance. If the series resistor test method is used, the measured voltage must be converted to current using the value of the series resistor (nominally 10 m $\Omega$ ).
- 5) If waveform departs from the Figure 2.5-62 waveform by more than 20%, check set up for problems and rectify before proceeding.

Check the GSFC Technical Standards Program website at <http://standards.gsfc.nasa.gov> or contact the Executive Secretary for the GSFC Technical Standards Program to verify that this is the correct version prior to use.

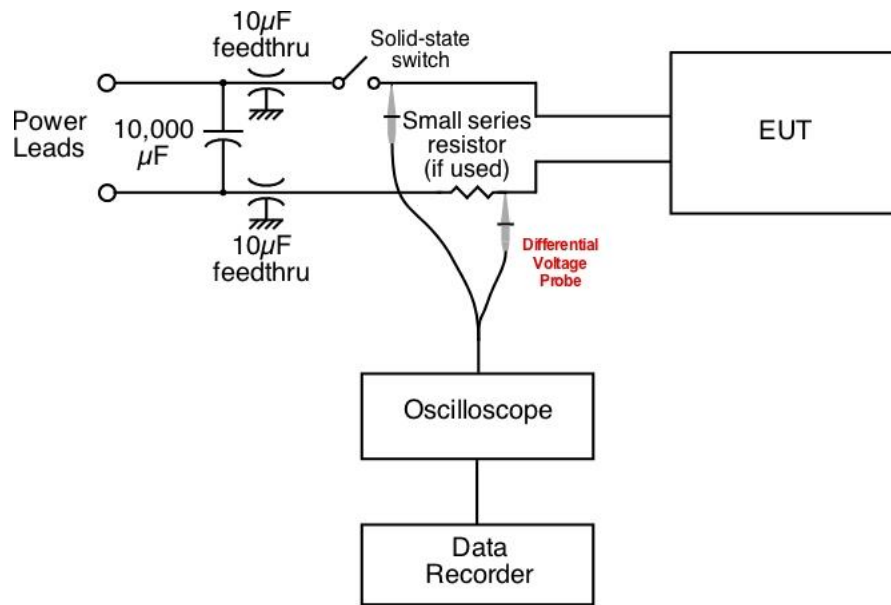

Figure 2.5-60. Measurement System Check (Current Probe)

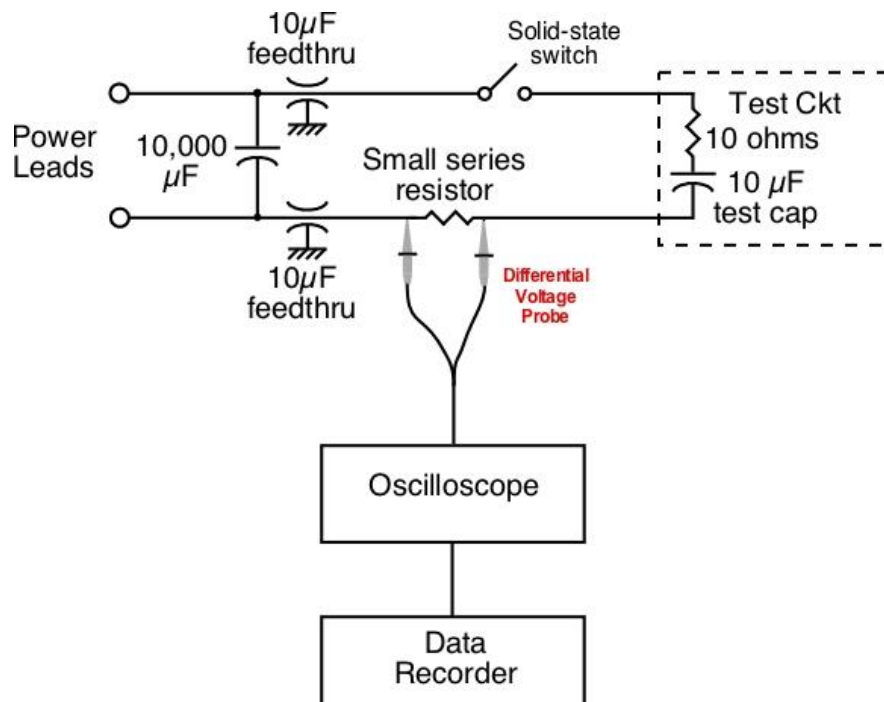

Figure 2.5-61. Measurement System Check (Series Resistor)

Check the GSFC Technical Standards Program website at <http://standards.gsfc.nasa.gov> or contact the Executive Secretary for the GSFC Technical Standards Program to verify that this is the correct version prior to use.

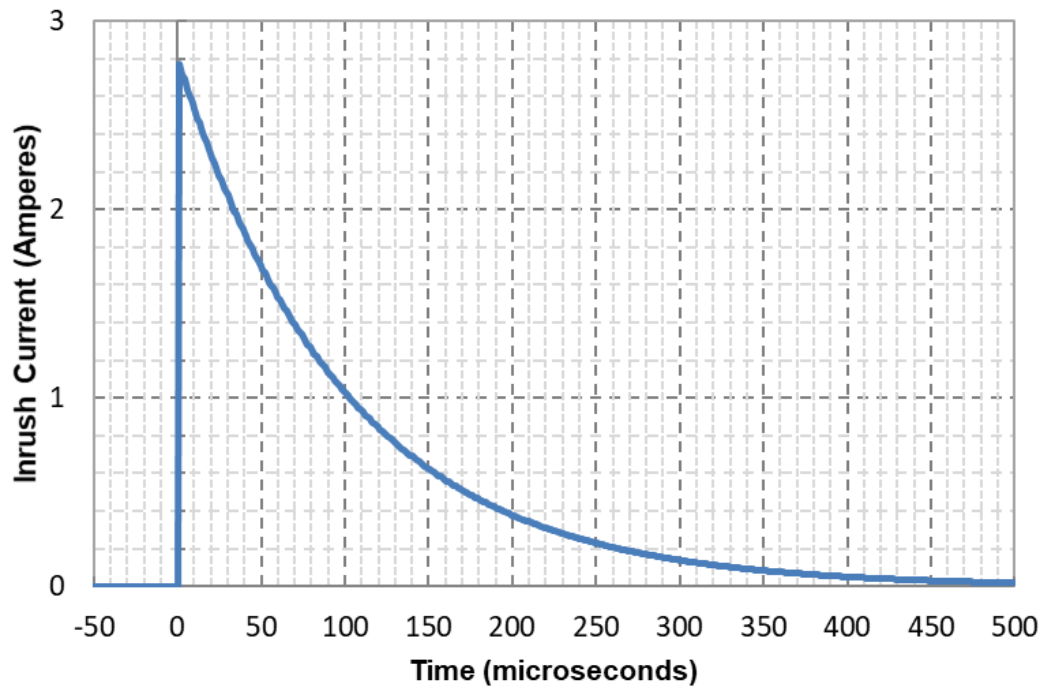

Figure 2.5-62. Inrush Current Calibration Waveform (20% Tolerance)

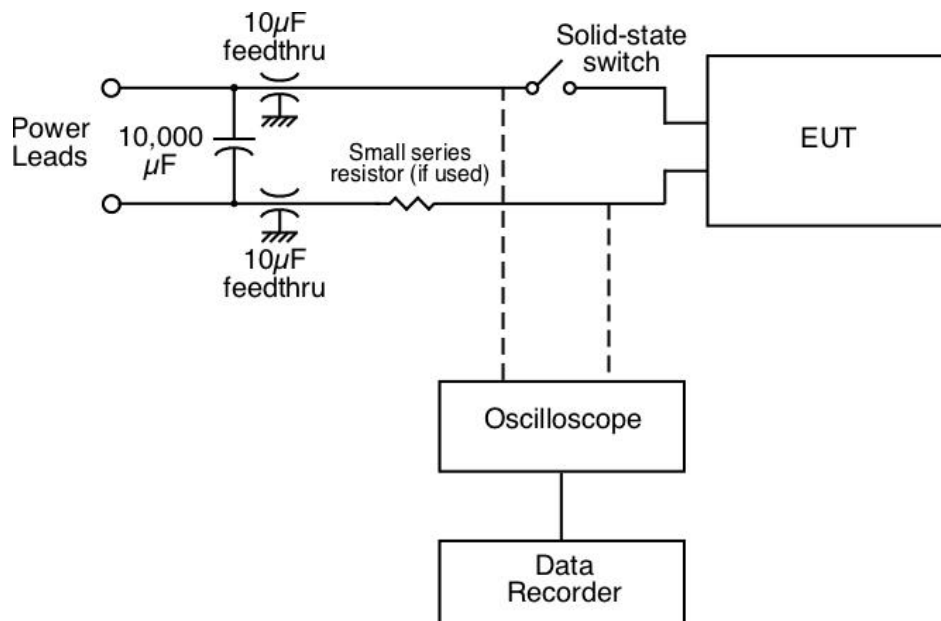

Figure 2.5-63. Input Power Voltage Sag Measurement Setup

Check the GSFC Technical Standards Program website at <http://standards.gsfc.nasa.gov> or contact the Executive Secretary for the GSFC Technical Standards Program to verify that this is the correct version prior to use.

#### Input Power Voltage Sag Measurement Procedure:

- 1) Configure the test setup for the power bus sag measurement as shown in Figure 2.5-6335. Ensure that the power switch is in the open position.
- 2) Set up the oscilloscope as follows:
  - a. 5 V/division sensitivity with 0 Volts at bottom of display grid for nominal 28 Vdc bus.
  - b. 50  $\mu$ s per division time base
  - c. Single sweep after trigger, with hold
  - d. Display such that leading edge of waveform is one division left of the left side of display grid
  - e. Trigger:
    - level set to 1 – 2 Volts below nominal bus potential
    - looking for negative going waveform (negative trigger slope)
- 3) Energize switch and look for waveform that sags more than 2.8 Volts (or 10% of nominal). If sag is greater than 10%, then provide additional line-to-line capacitance and/or decrease the impedance of the current monitoring device (especially if using the series resistor) as necessary. Measure again and repeat process until bus sag is within tolerance. When making multiple inrush measurements, ensure that test sample power supply filters have time to adequately discharge between measurements.

#### 2.5.3.3.4 Conducted Susceptibility, Primary Power Leads

A discussion of the CS101 requirement, test method, and tailoring guidelines are provided in the following subsections.

##### 2.5.3.3.4.1 Minimize Power Source Impedance (GEVS Capacitor Network)

In order for the CS101 test method to work as intended, most of the injected ripple must be dropped across the EUT power inputs, with minimal ripple appearing across the power source. This is accomplished by minimizing the power source impedance. For DC power sources, MIL-STD-462 suggests a 100  $\mu\text{F}$  capacitor across the power leads. For DC and single-phase AC power sources, MIL-STD-461G suggests placing a 10  $\mu\text{F}$  capacitor between the high (+) and return (-) power leads.

Note that the CS101 setup shown in MIL-STD-461G is also intended for platforms using AC power sources operating at 400 Hz. The value of 10  $\mu\text{F}$  is an upper limit on the line-to-line capacitance that may be placed across such an AC bus without significantly filtering the intentional 400 Hz signal. GSFC platforms do not use AC power buses; they use battery dominated DC power buses operating at or near +28 VDC. On DC power buses, the line-to-line capacitance need not be limited to 10  $\mu\text{F}$ .

The reactance of 10  $\mu\text{F}$  is approximately 530  $\Omega$  at 30 Hz, which means that it will be ineffective at lowering the power source impedance at the lower end of the CS101 frequency range. For this reason, the capacitor network specified in Figure 2.5-1 is recommended. This capacitor network consists of the pair of 10  $\mu\text{F}$  feedthrough capacitors specified by MIL-STD-462 along with a 10,000  $\mu\text{F}$  line-to-line capacitor. The reactance of the 10,000  $\mu\text{F}$  capacitor is approximately 0.5  $\Omega$  at 30 Hz. This value in shunt with the 10  $\mu\text{F}$  feedthrough capacitors will provide a low power source impedance over the entire CS101 frequency range, forcing most of the injected ripple to drop across the EUT power inputs as desired.

##### 2.5.3.3.4.2 Injection of Test Signal on High (+) Power Lead Only

MIL-STD-461G Section 5.7 states that CS101 is applicable to “DC input power leads, not including returns.” Section A.5.7 in the Application Guide of MIL-STD-461G further states:

“The required signal is applicable only to the high sides on the basis that the concern is developing a differential voltage across the power input leads to the EUT. The series injection technique in the test procedure results in the voltage dropping across the impedance of the EUT power input circuitry. The impedance of the power return wiring is normally insignificant with respect to the power input over most of the required frequency range. Common mode voltages evaluations are addressed by other susceptibility tests such as CS114 and RS103. Injection on a power return will result in the same differential voltage across the power input; however, the unrealistic condition will result in a large voltage at the return connection to the EUT with respect to the ground plane.”

When the power distribution point is close to the platform ground reference, the impedance between these two points is very small. Thus, only a small potential difference can develop between the (-) lead at the EUT and the ground reference. This is the case on most GSFC platforms, and in such cases, injecting on the (+) lead only is sufficient. Injection on the return (-) lead is unnecessary.

Check the GSFC Technical Standards Program website at <http://standards.gsfc.nasa.gov> or contact the Executive Secretary for the GSFC Technical Standards Program to verify that this is the correct version prior to use.

When the distance between the ground reference and the distribution point is quite long, the impedance can be relatively large. In such cases, a large potential difference can develop between the (-) lead of the EUT and the platform ground reference. This is the case on the International Space Station (ISS), on which this distance can be greater than 100 feet. For this reason, ISS requires CS01 to be performed on both the (+) and (-) leads.

ISS payloads must comply with the ISS specific documentation listed in section 2.5.1.1.

#### 2.5.3.3.4.3 Powering on Drive Amplifier Before Powering on EUT

The transformer injection method of CS101 has been shown to pose a potential damage risk to the EUT and the drive amplifier if proper precautions are not followed. The secondary winding of the transformer typically has an inductance of approximately 1 mH. When the drive amplifier is powered off, the transformer's primary windings are effectively open-circuited. As a result, the entire 1 mH of the secondary winding will be placed in series with the power lead to the EUT. Such a large inductance in series with the power source has been shown to cause instability and even damage to a switched mode power supply lacking adequate decoupling from the power source.

For these reasons, the power amplifier driving the coupling transformer **MUST** be powered up and allowed to stabilize prior to applying power to the EUT. Once the amplifier is powered on, its output impedance (typically a few ohms or less) will be connected across the transformer's primary windings reduced by the square of the turns ratio as it is reflected across the transformer secondary (more about this in the "Power/Current Limits" section.)

#### 2.5.3.3.4.4 Directly Monitor and Control Potential at EUT

The standard injection transformer used at GSFC is the Solar Electronics 6220-1A, which provides an additional secondary winding that may be used to monitor the voltage across the secondary. The Solar website provides a figure and an application note that gives a potentially misleading impression that it may be sufficient to monitor and control this potential in the control loop for the test. This is not correct. Per Kirchhoff's Voltage Law, the injected potential at the transformer secondary will be dropped around the entire circuit loop formed by the EUT input and the power source impedance. For this reason, the potential across the EUT input must be monitored and controlled directly, as shown in the figures in the main body of this document.

#### 2.5.3.3.4.5 Use of High Impedance Differential Voltage Probe

The basic CS101 setup in MIL-STD-461G calls for the oscilloscope's power cable to be connected to an isolation transformer. The isolation transformer is used to electrically float the oscilloscope's reference in order to avoid creating a ground loop with the return (-) power lead if the potential is measured with a standard single-ended voltage probe. This setup creates a potential shock hazard and is not recommended.

This problem is easily solved by monitoring the EUT input potential using a high impedance differential voltage probe. The probe itself will isolate the return (-) power lead from the oscilloscope reference. An alternative option is to use two single-ended probes and to display the difference between the channels (the reference leads for the two probes must be connected together). In either case, the oscilloscope may be properly grounded and the isolation transformer eliminated, resulting in a safer and simpler setup.

Check the GSFC Technical Standards Program website at <http://standards.gsfc.nasa.gov> or contact the Executive Secretary for the GSFC Technical Standards Program to verify that this is the correct version prior to use.

#### 2.5.3.3.4.6 Voltage Limits

The default CS101 limit in MIL-STD-461G specifies two curves. Curve #1 is for power buses of above +28 V, and Curve #2 is for power buses of +28 V or below. Curve #1 specifies a level of 6.3 Vrms (136 dB $\mu$ V) from 30 Hz to 5 kHz; Curve #2 specifies a level of 2 Vrms (126 dB $\mu$ V) in that frequency range. Both limits slope downward above 5 kHz at a rate of -20 dB/decade.

*NOTE: GSFC platforms have historically implemented a standard primary bus potential of +28 V<sub>DC</sub>. Some recent platforms implement a higher bus potential, e.g. +30 V<sub>DC</sub>. It is generally understood that Curve #2 applies to platforms that implement DC sources operating at bus potentials at or near +28 V<sub>DC</sub>.*

These default CS101 limits are defined in order to provide margin with respect to the power generation characteristics defined in MIL-STD-704 for aircraft. The ripple levels in MIL-STD-704 are based on electromechanical power sources, i.e. rotating machinery that turns a shaft that provides motive power to an electrical generator. Such power sources have significant ripple generated by the source itself.

GSFC platforms do not use electromechanical power sources. GSFC spacecraft use solar panel arrays that charge a battery and provide direct current to loads. This type of power system controls bus potential using a Pulse Width Modulation (PWM) system operating at a frequency determined by the platform, which can range from a few hundred Hz to a few hundred kHz. Such power sources will have source-generated ripple at the PWM frequency, but this ripple is significantly less than that generated by the electromechanical sources specified in MIL-STD-704. Any ripple at frequencies other than the PWM frequency and its harmonics is dominated by load-induced effects, which are controlled by conducted emissions requirements.

On GSFC platforms, the voltage ripple for power distribution systems is generally specified in the time domain as having a maximum aggregate amplitude of 1 V peak-to-peak. Because the spectral distribution of this ripple is not specified, a conservative approach is to specify a CS101 frequency-domain limit that envelopes this time-domain specification at all frequencies. Given the above, a tailored CS101 voltage limit for GSFC platforms of 1 Vrms (2.8 V peak-to-peak) from 30 Hz to 150 kHz is expected to be more than sufficient for most GSFC platforms. If the ripple from the spacecraft power subsystem is expected to be higher than 1 V peak-to-peak, the CS101 limit should be further tailored accordingly.

#### 2.5.3.3.4.7 Power/Current Limits

Prior to applying the test signal to the EUT, it is necessary to limit the amount of power that may be applied to the EUT. This is done by pre-calibrating the test signal using the setup shown in Figure 2.5-64. The purpose of the pre-calibration step is to create a “look-up table” that defines the signal generator level at each frequency required to dissipate a specified power level into a 0.5  $\Omega$  load.

This “look-up table” defines the maximum signal generator setting at each frequency when applying the test signal to the EUT. At each frequency, the signal level is increased until either the voltage limit or the maximum signal generator setting is reached. This is inherent in the definition of the CS101 limit in MIL-STD-461G, Section 5.7.2:

“The EUT shall not exhibit any malfunction, degradation of performance, or deviation from specified indications, beyond the tolerances indicated in the individual equipment or subsystem specification, when subjected to a test signal with voltage levels as specified in Figure CS101-1. The requirement is also met when the power source is adjusted to dissipate the power level shown in Figure CS101-2 in a 0.5  $\Omega$  load and the EUT is not susceptible.”

MIL-STD-461C defines a power limit for CS01 of 50 W from 30 Hz to 50 kHz. This equates to 5 Vrms across the 0.5  $\Omega$  load, which corresponds to the default voltage limit from 30 Hz to 1.5 kHz as previously discussed. This also corresponds to a current of 10 Arms through the load.

MIL-STD-461G defines a power limit of 80 W from 30 Hz to 5 kHz. This equates to 6.3 Vrms across the 0.5  $\Omega$  load, which corresponds to the voltage limit defined by Curve #1 as discussed previously. This also corresponds to a current of 12.5 Arms through the load.

The tailored 1 Vrms voltage limit defined in Figure 2.5-14 corresponds to 2 W dissipated in the 0.5  $\Omega$  load and 2 Arms through the load. Clearly, the default power limits of 50 W or 80 W are quite excessive in combination with a voltage limit of 1 Vrms.

The actual purpose of the power limit is to set a short-circuit current limit. This is best illustrated through an examination of equivalent circuits. One equivalent circuit including the transformer is shown in Figure 2.5-65, and a second equivalent circuit showing the amplifier’s output impedance  $R_O$  referred to the transformer secondary,  $R_{EFF}$ , is shown in Figure 2.5-66. Because the Solar 6220-1A has a turns ratio of 2:1,  $R_{EFF} = R_O/4$ .

The pre-calibration step effectively defines  $V_{OC}$  at each frequency, the maximum effective source potential “upstream” of the effective output impedance  $R_{EFF}$  as shown in Figure 2.5-66. This is the open-circuit potential that would appear at the transformer secondary with no load. When the EUT’s input impedance is greater than 0.5  $\Omega$  at any given frequency, the injection circuit will have no trouble establishing the desired potential at the EUT. When the EUT’s input impedance  $R_{EUT}$  drops below 0.5  $\Omega$  at any given frequency, the closed-circuit potential across the load  $V_{CC}$ , as a function of frequency, will be limited to:

$$V_{CC}(f) = V_{OC}(f) \cdot \frac{R_{EUT}(f)}{R_{EUT}(f) + R_{EFF}(f)}$$

The current applied to the EUT,  $I_{EUT}$ , as a function of frequency will be:

$$I_{EUT}(f) = \frac{V_{OC}(f)}{R_{EUT}(f) + R_{EFF}(f)}$$

The maximum current will occur when the EUT’s input impedance drops to near 0  $\Omega$  (short-circuit) at any given frequency. Thus, the ultimate goal of the pre-calibration step is to define the short-circuit current  $I_{SC}$  that may be applied to the EUT at each frequency:

$$I_{SC}(f) = \frac{V_{OC}(f)}{R_{EFF}(f)}$$

Thus,  $I_{SC}$  clearly depends directly on the output impedance of the drive amplifier. MIL-STD-462 specifies that that  $R_{EFF}$  shall be 0.5  $\Omega$  or less; MIL-STD-461F does not specify a value for  $R_{EFF}$ .

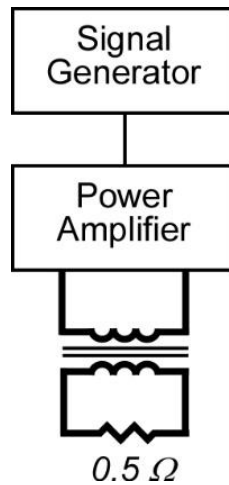

**Figure 2.5-64. CS01/CS101 Pre-Calibration Setup**

CS01/CS101 testing at GSFC is typically performed using either the model 2352-1 or the model 6552-1A audio amplifier, both manufactured by Solar Electronics. The 2352-1 has a specified output impedance of  $2\ \Omega$ , which maps to  $R_{EFF} = 0.5\ \Omega$  referred to the transformer secondary. The 6552-1A has a specified output impedance of  $2.4\ \Omega$ , which maps to  $R_{EFF} = 0.6\ \Omega$  referred to the transformer secondary.

Both of these amplifiers were designed specifically for CS01/CS101. As such, they work over the specified frequency range of 30 Hz to 150 kHz, but they block any DC component. If a different audio amplifier is used, care must be taken to ensure that it cannot pass a significant DC component onto the transformer primary. It has been shown that applying an uncontrolled DC offset to the transformer primary can cause instability and potential damage to the EUT.

If unknown,  $R_{EFF}$  may be easily measured using the following procedure (reproduced from MIL-STD-462, CS01 Test Method, paragraph 4.1):

- 1) Apply a potential to the primary of the transformer and measure the open-circuit potential at the secondary ( $V_{OC}$ ).
- 2) Connect a known load,  $R_L$  ( $0.5\ \Omega$  recommended), across the transformer secondary and measure the closed-circuit potential at the secondary ( $V_{CC}$ ).
- 3) Calculate  $R_{EFF}$  as follows:

$$R_{EFF} = R_L \frac{(V_{OC} - V_{CC})}{V_{CC}}$$

- 4) Repeat steps 1-3 at one frequency per octave from 30 Hz to 150 kHz.

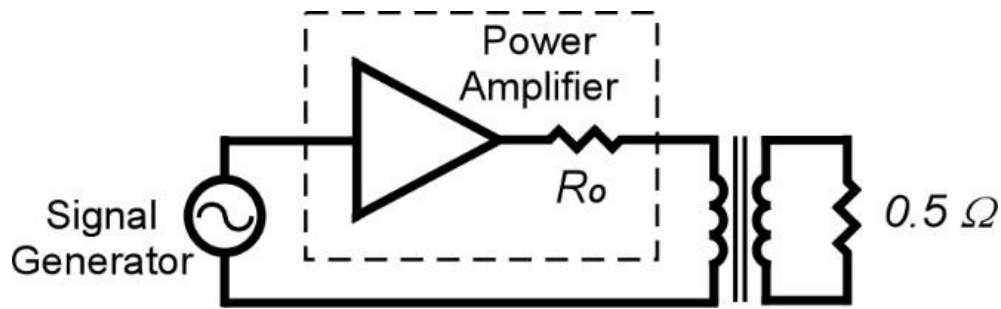

Figure 2.5-65. CS101 Pre-Calibration Equivalent Circuit, Transformer Included

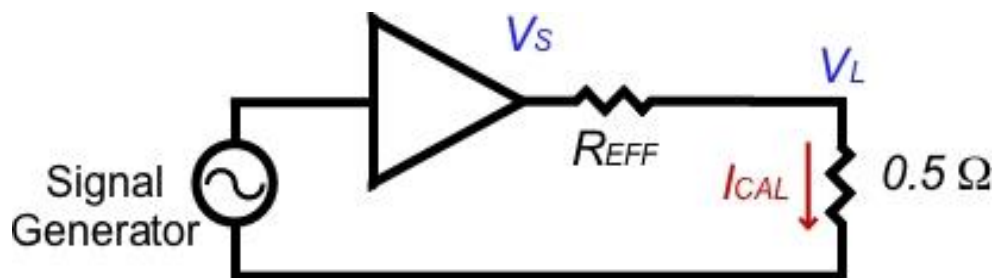

Figure 2.5-66. CS101 Pre-Calibration Equivalent Circuit, Referred to Transformer Secondary

The impact of  $R_{EFF}$  on  $I_{SC}$  is best illustrated through a few examples:

- As stated above, the 50 W power limit corresponds to 5 Vrms across the 0.5 Ω load. If using the 2352-1, then  $R_{EFF} = 0.5 \Omega$ ,  $V_{OC} = 10$  Vrms, and  $I_{SC} = 20$  Arms. If using the 6552-1A, then  $R_{EFF} = 0.6 \Omega$ ,  $V_{OC} = 11$  Vrms, and  $I_{SC} = 18.3$  Arms.
- Likewise, a 2 W power limit corresponds to 1 Vrms across the 0.5 Ω load. If using the 2352-1, then  $R_{EFF} = 0.5 \Omega$ ,  $V_{OC} = 2$  Vrms, and  $I_{SC} = 4$  Arms. If using the 6552-1A, then  $R_{EFF} = 0.6 \Omega$ ,  $V_{OC} = 2.2$  Vrms, and  $I_{SC} = 3.7$  Arms.

But recall that the output impedance of the drive amplifier is neither specified nor controlled. What happens to  $I_{SC}$  when  $R_{EFF}$  is much lower than 0.5 Ω, e.g. 0.1 Ω?

- The 50 W power limit still corresponds to 5 Vrms across the 0.5 Ω load. If  $R_{EFF} = 0.1 \Omega$ , then  $V_{OC} = 6$  Vrms and  $I_{SC} = 60$  Arms.
- The 2 W power limit still corresponds to 1 Vrms across the 0.5 Ω load. If  $R_{EFF} = 0.1 \Omega$ , then  $V_{OC} = 1.2$  Vrms and  $I_{SC} = 12$  Arms.

Therefore...

**THE SHORT-CIRCUIT CURRENT APPLIED TO THE EUT MAY BE SIGNIFICANTLY HIGHER THAN INTENDED IF RELYING ONLY ON THE PRE-CALIBRATION STEP USING AN AMPLIFIER WITH AN OUTPUT IMPEDANCE OF LESS THAN 2 Ω ( $R_{EFF} < 0.5 \Omega$ ). IF THE PRE-CALIBRATION STEP IS USED, THE AMPLIFIER'S OUTPUT IMPEDANCE MUST BE CHARACTERIZED AND ITS IMPACTS ON SHORT-CIRCUIT CURRENT WELL UNDERSTOOD.**

Check the GSFC Technical Standards Program website at <http://standards.gsfc.nasa.gov> or contact the Executive Secretary for the GSFC Technical Standards Program to verify that this is the correct version prior to use.

An alternative to the pre-calibration step is to monitor and control the current of the injected signal directly as shown in Figure 2.5-17. This current monitor may be incorporated into the control loop with a defined “not-to-exceed” value for short-circuit current. For the tailored 1 Vrms and 2 W limit, the equivalent short-circuit current limit is 4 A.

The current monitor/control method is the default method for audio frequency conducted susceptibility specified by AIAA S-121, “Electromagnetic Compatibility Requirements for Space Equipment and Systems.”

An additional benefit to this approach is the EUT’s input impedance as a function of frequency may be calculated directly as the ratio of the applied potential to the applied current at each frequency. The measured input impedance may be provided to the spacecraft power subsystem provider as part of a power bus stability analysis.

#### 2.5.3.3.4.8 Alternate Test Method and Limits

As mentioned in Section 2.5.3.3.4.3, the MIL-STD-461G CS101 test method, along with its CS01 predecessor from MIL-STD-462, has been shown to pose a potential damage risk to the EUT if proper precautions are not followed.

In order to mitigate these concerns, an alternative injection technique similar to modern bulk current injection technology is available. It was developed for the Apollo program Lunar Excursion Module (LEM) in the mid-1960s. This technique uses an injection clamp instead of a coupling transformer as shown in Figure 2.5-45. The recommended injection clamp is the Solar Electronics 6541-1 or equivalent. This device inserts approximately 0.01  $\Omega$  in series with each wire passing through it, which significantly reduces the risks associated with the 1 millihenry series inductance in the CS101 test method.

The Solar Model 6541-1 has a multiple pin connector instead of the more typical coaxial connector. The pins that connect to the power amplifier output are “C” and “D”. The other pins are not connected for this test.

The balance of the test is identical to the MIL-STD-461G CS101 test method with the 6541-1 injection clamp taking the place of the coupling transformer. A 100-Watt audio amplifier is required to drive the injection clamp. Note from Figure 2.5-45 that the signal is injected as a Differential Mode signal.

If this test method is used, the recommended voltage and power limits are shown in Figures 2.5-45 and 2.5-46, respectively. If the actual ripple characteristics of the spacecraft power subsystem exceed the levels below 500 Hz shown in Figure 2.5-19, then the standard CS101 injection transformer must be used.

The default CS01 limit in MIL-STD-461C is specified from 30 Hz to 1.5 kHz as “10% of supply voltage or 5 Volts (rms), whichever is less”. The limit then slopes linearly downward to a level of 1 Vrms at 50 kHz.

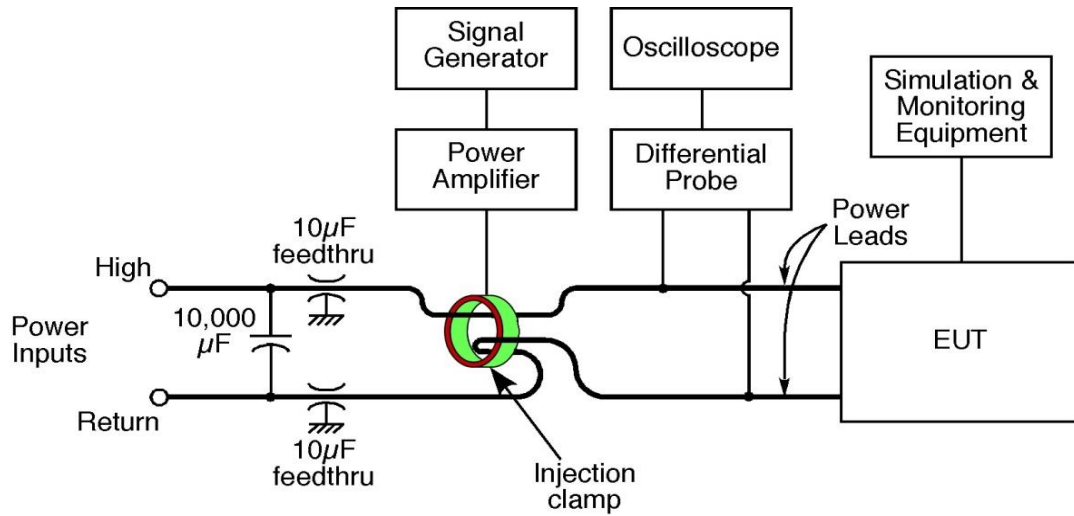

**Figure 2.5-67. Conducted Susceptibility Alternate Test Setup (Differential Mode, 30 Hz to 150 kHz)**

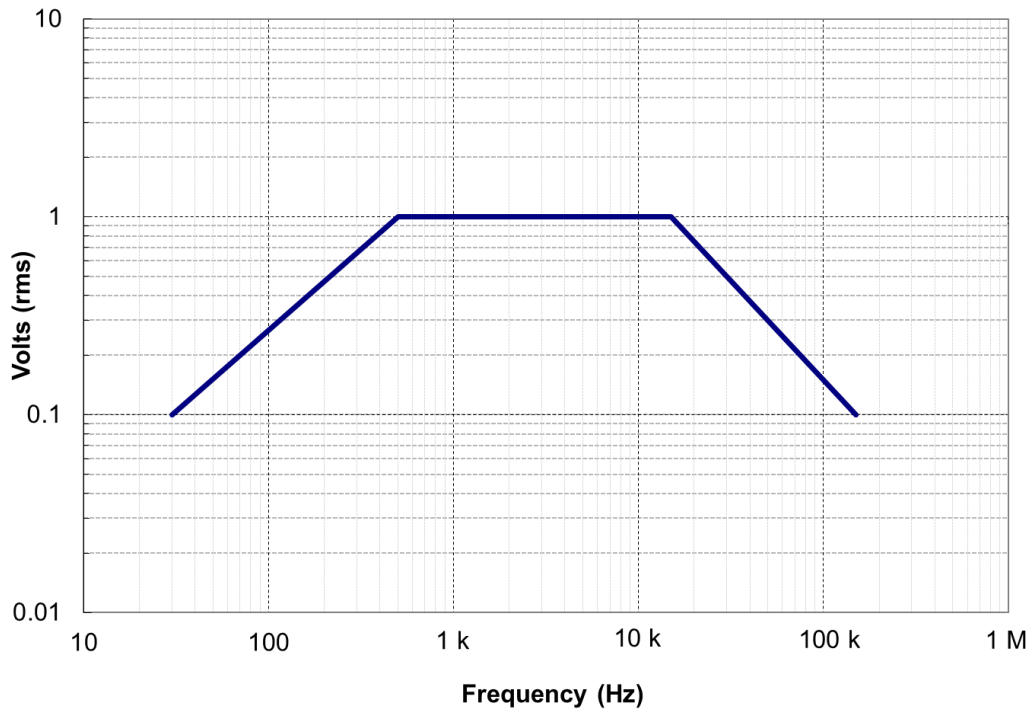

Figure 2.5-68. CS101 Alternate Voltage Limit

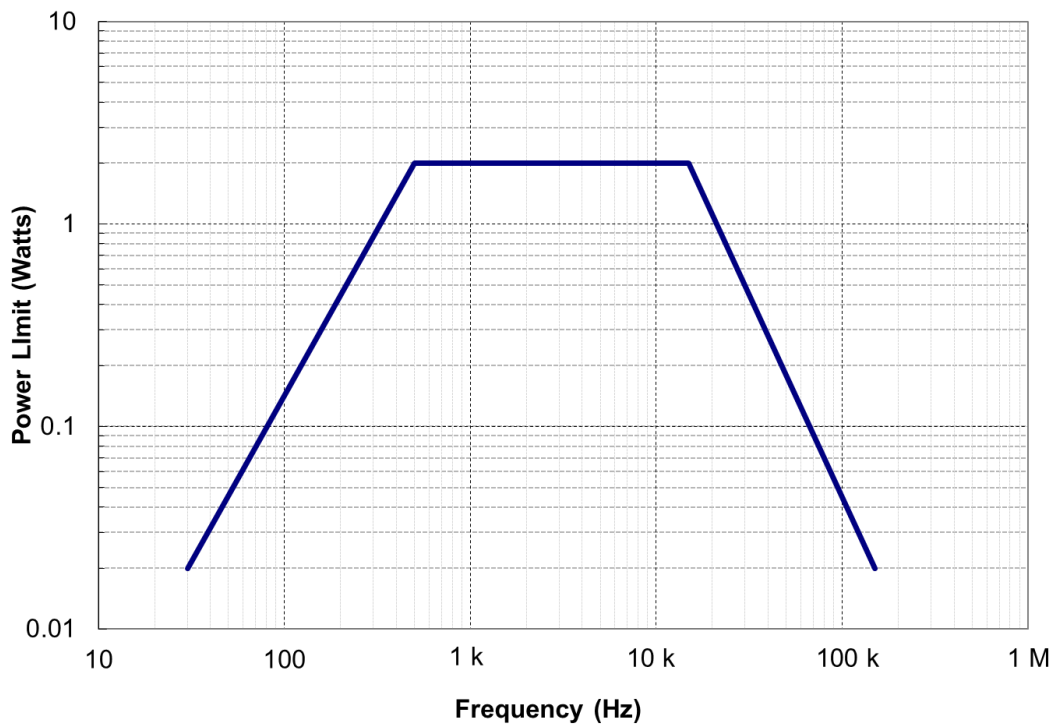

Figure 2.5-69. CS101 Alternate Power Limit

Check the GSFC Technical Standards Program website at <http://standards.gsfc.nasa.gov> or contact the Executive Secretary for the GSFC Technical Standards Program to verify that this is the correct version prior to use.

#### 2.5.3.3.5 Conducted Susceptibility, Transients, Power Leads

The MIL-STD-461G CS106 requirement was developed specifically for Navy applications, submarine and surface ship equipment in particular. The 5 microsecond pulse represents the typical transient observed on these platforms (shown in MIL-STD-461G Figure CS106-1).

With the release of MIL-STD-461G in 2015, the CS106 requirement fell out of favor and was no longer included.

The 10 microsecond pulse specified by the CS06 requirement of MIL-STD-461C is preferred over the 5 microsecond pulse of CS106 because:

- it is more stringent limit than the CS106 pulse, and
- the CS06 transient generator is a standard piece of EMI test equipment in any EMI test lab

For all platforms, the negative transient will be applied. For platforms that include rapidly changing inductive loads that are expected to generate significant back emf onto the bus, the positive transient will be applied as well.

Although this limit is expected to be sufficient for most platforms, it must be compared against the worst-case expected transients generated by equipment on the platform. If significantly longer transients are expected, the limit must be tailored accordingly, and a different transient generator must be used.

An extensive discussion of the mechanisms that produce such transients, as well as the history of the CS06 and CS106 test methods, is provided in the application note entitled, "CS06 – Conducted Transients on Primary Power Lines," available on the GEVS Application Notes page of the GSFC EMC Working Group SPACES site:

<https://spaces.gsfc.nasa.gov/display/EMCWG/GEVS+Application+Notes>

#### 2.5.3.3.6 Conducted Susceptibility, Bulk Cable Injection, 10 kHz to 200 MHz

##### 2.5.3.3.6.1 Conducted Susceptibility, Power and Signal Cables, Common Mode

The MIL-STD-461G CS114 limits are specifically defined in order to simulate currents that will be developed on platform cabling from electromagnetic fields generated by antenna transmissions both on and off the platform. In MIL-STD-461G Section A.5.13, the ratio of common mode current to electric field intensity is given as 1.5 mA per V/m. Using this relationship, the CS114 limit curves in MIL-STD-461G correspond to radiated susceptibility (RS103) limits ranging from 5 V/m up to 200 V/m as follows:

MIL-STD-461G Curve #1:	5 V/m
MIL-STD-461G Curve #2:	10 V/m
MIL-STD-461G Curve #3:	20 V/m
MIL-STD-461G Curve #4:	50 V/m
MIL-STD-461G Curve #5:	200 V/m

While these types of levels may be expected at the launch site, they are significantly higher than typical on-orbit levels, and they are almost certainly unnecessarily stringent for controlling cable-to-cable crosstalk.

A more typical on-orbit level is 2 V/m as discussed in Section 2.5.2.4.2. This forms the basis for the high frequency portion of the GEVS limit shown in Figure 2.5-21. In addition to protecting against crosstalk, testing to these levels will demonstrate the ability of the victim cables to withstand typical on-orbit electric fields.

Shielding options may be limited on some potential victim cables, such as those connecting to equipment operating at cryogenic temperatures. Such cables may be susceptible to levels lower than those shown in Figure 2.5-21. These cables must be identified and characterized as early as possible for susceptibility to common mode currents. The thresholds of susceptibility will be documented in the project EMCCP, and the Common Mode Conducted Emissions limit for neighboring culprit cables must be defined accordingly in order to protect the victim cables from crosstalk.

Shielding options may also be limited on potential culprit cables. If so, the crosstalk concern must be addressed by properly separating victim and culprit cables.

As stated above, the default CS114 limit curves defined in MIL-STD-461G are derived directly from corresponding RS103 limits. In order to understand this relationship, it is important to understand the fundamentals of field-to-wire coupling and how they relate to the bulk cable injection method of CS114. These topics are discussed in the following subsections.

The mechanism of crosstalk is discussed in general terms in section 2.5.3.3.2.3. As shown in Figure 2.5-42, a common mode current on a culprit cable generates a magnetic flux that couples into the loop formed by a victim cable over a ground plane.

As discussed in the next section, the more general case of an incident plane electromagnetic wave also couples magnetic flux into the victim loop. Irrespective of the nature of the culprit, when a magnetic flux is coupled into a victim cable loop, analysis of resultant potentials and currents proceeds identically. As such, the analysis in the following sections is easily applied to magnetic coupling resulting from crosstalk, as discussed in further detail in the GEVS application note entitled, "Inductive Crosstalk at the System Level," available on the "GEVS Application Notes" page of the GSFC EMC Working Group SPACES site:

<https://spaces.gsfc.nasa.gov/display/EMCWG/GEVS+Application+Notes>

### 2.5.3.3.6.1.1 Field-to-Wire Coupling

As discussed in section 2.5.3.3.2 for CMCE measurements, a bulk cable must be considered a wire-above-ground transmission line, the parameters of which are discussed in section 2.5.3.3.9. Field-to-wire coupling is discussed in detail in “On Field-to-Wire Coupling Versus Conducted Injection Techniques”, Javor, Ken, 1997 IEEE EMC Symposium record. This paper is available on the “Educational Documents” page of the GSFC EMC Working Group SPACES site:

<https://spaces.gsfc.nasa.gov/display/EMCWG/Educational+Documents>

While it is understood that field-to-wire coupling and crosstalk are distributed effects, i.e. that the coupled potential is distributed along the length of the wire, the following analysis treats the coupled potential as a lumped parameter. This approach significantly simplifies the analysis and is considered sufficient for the purposes of defining an equivalent limit for the CS114 test method, which applies the injected level as a bulk signal at one end of the cable under test.

Figure 2.5-70 shows a notional diagram of the fields from a plane electromagnetic wave impinging upon a wire of length  $l$  at a height  $h$  above a ground plane. The direction of the incident wave as shown, with the magnetic field vector  $H$  penetrating the loop at normal incidence, will generate the maximum coupling through the loop. Faraday’s law of electromagnetic induction states that the magnitude of the coupled potential into a loop is the time rate of change of the magnetic flux  $\Phi$  through the loop:

$$|V| = \left| \frac{d\Phi}{dt} \right|$$

For an incident plane electromagnetic wave, the magnetic flux density  $B$  is:

$$B = B_0 e^{j(\omega t - \beta z)} = \mu H_0 e^{j(\omega t - \beta z)}$$

The magnetic field intensity  $H$  is related to the electric field intensity  $E$  as follows:

$$H_0 = \frac{E_0}{\eta} = \frac{E_0}{\sqrt{\mu/\epsilon}}$$

Thus:

$$B = \frac{\mu E_0}{\sqrt{\mu/\epsilon}} e^{j(\omega t - \beta z)} = \sqrt{\mu\epsilon} \cdot E_0 e^{j(\omega t - \beta z)} = \frac{E_0}{c} e^{j(\omega t - \beta z)}$$

The total magnetic flux through the loop is the integral of  $B$  over the loop area. For a plane wave, the field is constant over the height. Thus, the integral need only be taken over the length:

$$\Phi = \frac{h E_0}{c} \int_0^l e^{j(\omega t - \beta z)} dz = -\frac{h E_0}{\beta c} [e^{j(\omega t - \beta l)} - e^{j\omega t}]$$

The time rate of change of  $\Phi$  is:

$$V = \frac{d\Phi}{dt} = -\frac{j\omega h E_0}{\beta c} [e^{j(\omega t - \beta l)} - e^{j\omega t}]$$

Check the GSFC Technical Standards Program website at <http://standards.gsfc.nasa.gov> or contact the Executive Secretary for the GSFC Technical Standards Program to verify that this is the correct version prior to use.

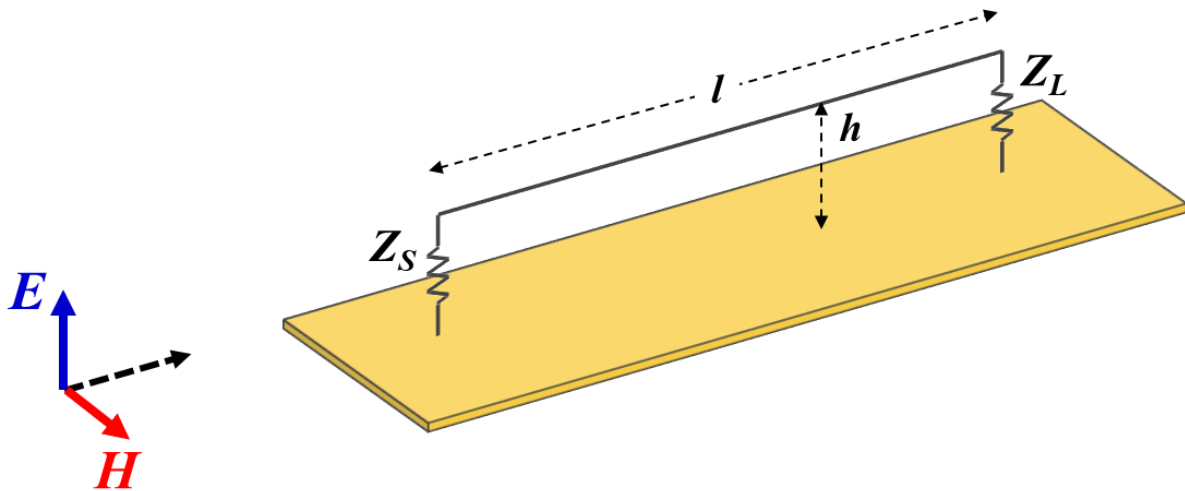

**Figure 2.5-70. Plane Electromagnetic Wave Impinging On Wire-Above-Ground**

Because  $\beta = \omega/c$ , the expression simplifies to:

$$V = -jhE_0[e^{j(\omega t - \beta l)} - e^{j\omega t}]$$

Taking the real part gives:

$$V = hE_0[-\sin(\omega t - \beta l) + \sin(\omega t)]$$

Further simplification is facilitated by the following trigonometric identity:

$$\sin A - \sin B = 2 \sin\left(\frac{A - B}{2}\right) \cos\left(\frac{A + B}{2}\right)$$

Thus:

$$V = 2hE_0 \sin\left(\frac{\beta l}{2}\right) \cos(2\omega t - \beta l)$$

The maximum value will occur when the time dependent cosine term equals unity, resulting in the following transfer function in terms of  $l/\lambda$ :

$$\frac{V}{E_0} = 2h \sin\left(\frac{\beta l}{2}\right) = 2h \sin\left(\frac{\pi l}{\lambda}\right)$$

MIL-STD-461G specifies that for all tests, all interconnecting cables will be placed at a height  $h = 5 \text{ cm}$  above the ground plane. Thus,  $h = 5 \text{ cm}$  will be used throughout all of the following analysis.

The  $V/E$  transfer function as a function of  $l/\lambda$  for  $h = 5 \text{ cm}$  is shown in Figure 2.5-71. The transfer function has nulls at frequencies for which  $l$  is an integer multiple of  $\lambda$ , and it has peaks at frequencies for which  $l$  is an odd multiple of  $\lambda/2$ .

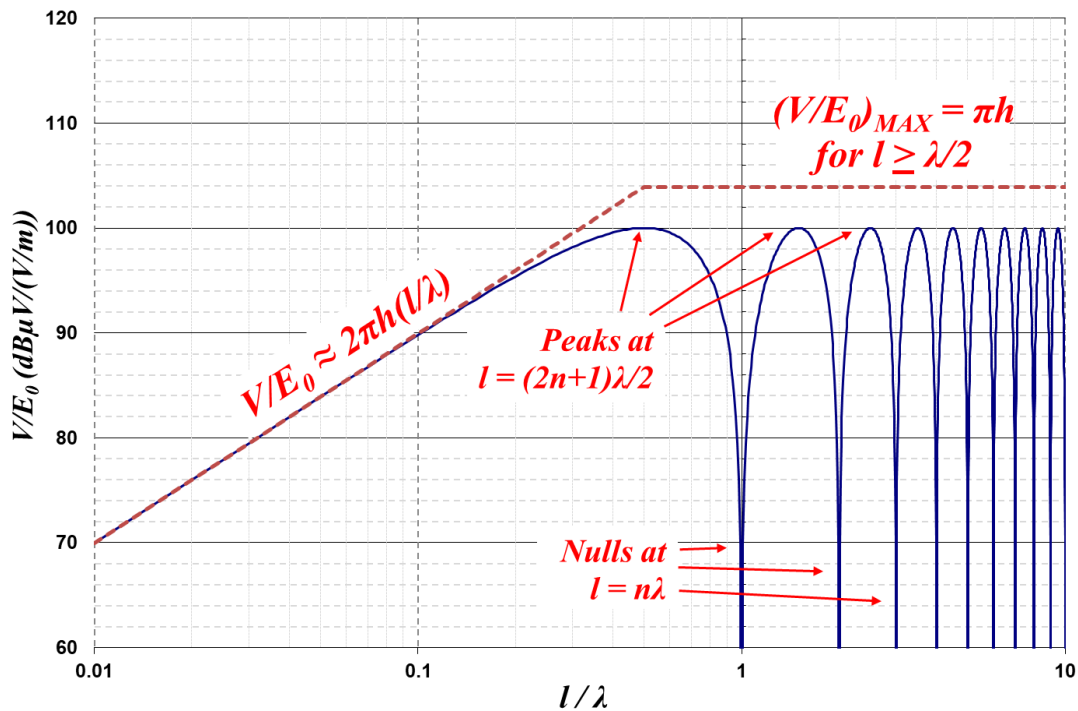

**Figure 2.5-71.  $V/E$  for Wire Above Ground,  $h = 5\text{ cm}$**

Using the simplification that  $\sin(x) \approx x$  for  $x \ll 1$ , at frequencies for which the wire is electrically short ( $l < \lambda/10$ ), the relationship simplifies to:

$$\left(\frac{V}{E_0}\right)_{\text{short}} \approx 2\pi h \left(\frac{l}{\lambda}\right)$$

Thus, at frequencies for which the wire is electrically short, the induced potential increases linearly with  $l/\lambda$ , which means it increases linearly with frequency.

The envelope shown by the dashed line is given by this linear relationship extended up to its maximum value at  $l = \lambda/2$ , given by:

$$\left(\frac{V}{E_0}\right)_{\text{MAX}} = \pi h$$

This value is extended as an asymptote for  $l > \lambda/2$ . For  $h = 5\text{ cm}$ ,  $(V/E_0)_{\text{MAX}} \approx 104\text{ dB}\mu\text{V}/(\text{V}/\text{m}) \approx 150\text{ mV}/(\text{V}/\text{m})$ .

The physical significance of Figure 2.5-71 for  $l > \lambda/2$  is that the coupled magnetic flux through the loop includes both positive and negative contributions, resulting in some cancellation of the net coupled flux. This further results in the decrease in the net coupled potential for  $l > \lambda/2$  as shown. When the length is a multiple of a wavelength, the positive and negative magnetic flux contributions completely cancel, and the net coupled potential is zero as shown.

For the purposes of defining a CS114 injected current limit, the envelope of  $V/E_0$  shown by the dashed line in Figure 2.5-71 is sufficient and greatly simplifies the remaining analysis. Therefore, this envelope will be used for the remaining discussion.

The resulting current on the wire is determined by the impedance of the wire-above-ground transmission line. As discussed in section 2.5.3.3.9, the characteristic impedance  $Z_0$  can span a range of values up to a few hundred ohms (300  $\Omega$  typical). For the purposes of performing bulk current injection (BCI) using the CS114 test method, it is desirable to precalibrate the injected level into a known and controlled impedance. The precalibrated levels are then applied to the cable under test (CUT) with a maximum “target” current as discussed below.

The CS114 test method specifies precalibration into a standard 50  $\Omega$  fixture with 50  $\Omega$  terminations at each end, giving a total loop impedance of 100  $\Omega$  (40 dB $\Omega$ ). Thus, 50  $\Omega$  will be used as the standardized value of  $Z_0$  in the remaining discussion.

Figure 2.5-72 shows the general calibration curve  $I_C/E_0$  when the envelope of  $V/E_0$  is applied to the 100  $\Omega$  (40 dB $\Omega$ ) calibration fixture. The level in the high frequency plateau is 64 dB $\mu$ A per V/m, or 1.5 mA per V/m, which provides the basis for that relationship stated in MIL-STD-461.

While it is useful to pre-calibrate into a known and controlled impedance, it is important to understand that in most cases, the wire represents a shielded cable with the shield terminated directly to chassis at both ends. Thus, the implications for injecting the precalibrated levels into a wire shorted at both ends must be considered.

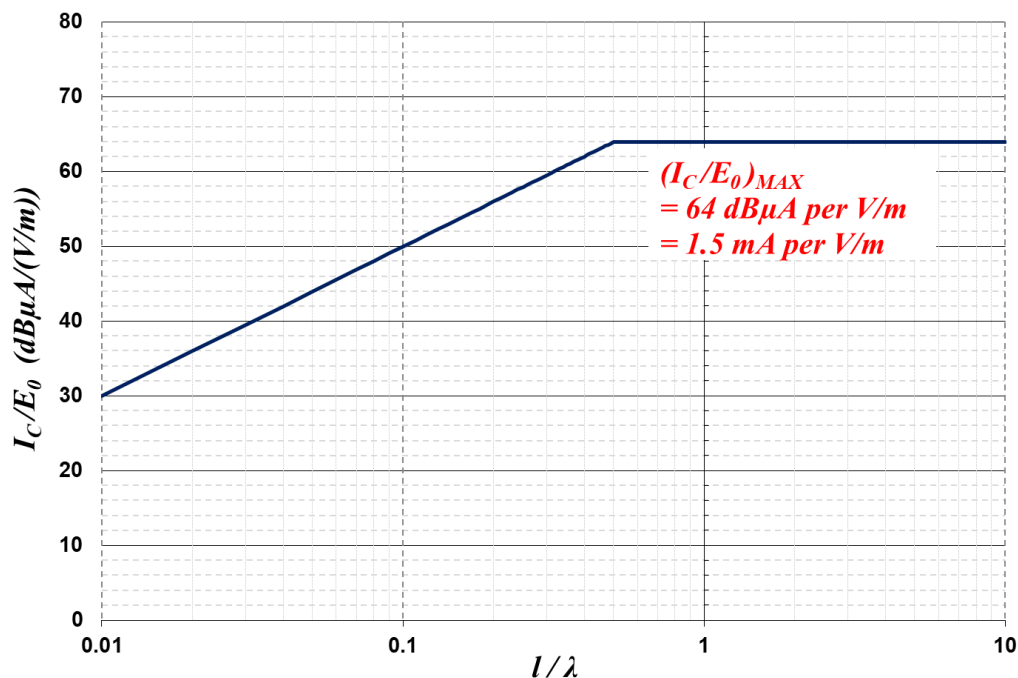

**Figure 2.5-72.  $I_C/E_0$  into 100  $\Omega$  CS114 Calibration Fixture**

When the wire is electrically short, the impedance is dominated by the inductance:

$$Z_{short} = 2\pi f L l$$

where  $L$  is the inductance per unit length.

Multiplying by  $c/c$  gives:

$$Z_{short} = \frac{2\pi f}{c} c L l = \frac{2\pi}{\lambda} \frac{1}{\sqrt{LC}} L l = 2\pi \sqrt{\frac{L}{C}} \cdot \left(\frac{l}{\lambda}\right) = 2\pi Z_0 \left(\frac{l}{\lambda}\right)$$

where  $C$  is the capacitance per unit length.

Thus, when the wire is electrically short,  $V/E_0$  and  $Z$  both increase linearly with  $l/\lambda$ . When dividing  $V/E_0$  by  $Z$ , the  $l/\lambda$  dependence cancels and  $V/E_0$  again has a constant value that is inversely proportional to  $Z_0$ :

$$\left(\frac{V}{E_0}\right)_{short} \approx \frac{h}{Z_0}$$

When  $l = \lambda/2\pi$ , the impedance reaches its high frequency asymptote value of  $Z_0$ , and  $V/E_0$  again has a constant value that is inversely proportional to  $Z_0$ :

$$\left(\frac{V}{E_0}\right)_{long} \approx \frac{\pi h}{Z_0}$$

This is the same value in this frequency range as the case for the matched line.

These levels are shown by the green curve in Figure 2.5-73. The levels for  $l > \lambda/2\pi$  are 6 dB above the corresponding levels for  $V/E_0$ , which provides the basis for injecting up to 6 dB above the precalibrated current as specified by the CS114 test method.

Historically, there have been two different approaches for defining the maximum current to be applied to the cable under test (CUT). MIL-STD-461E/F specified that the maximum applied current to the CUT was 6 dB higher than the pre-calibrated level all across the frequency range as shown by the red dashed curve in Figure 2.5-74. When compared against the dashed green curve in Figure 2.5-73, this approach clearly presents an undertest at low frequencies for which  $l < \lambda/8$ .

MIL-STD-461G reverted to the original approach specified by MIL-STD-461D/462D, which was that the maximum current applied to the CUT was to be 2x (6 dB) higher than the level in the flat part of the curve used for pre-calibration as shown by the solid red line in Figure 2.5-74. Although this level presents an overtest for  $l < \lambda/2$  as a representation of field-to-wire coupling, it is preferable to the MIL-STD-461E/F approach because it provides a worst-case. In addition, it provides a good basis for addressing the risk of crosstalk at these frequencies. These concerns will be discussed further in the following subsections.

The CS114 curves specified in MIL-STD-461G show the  $l = \lambda/2$  corner frequency at 1 MHz, which corresponds to a cable length of 150 meters. While cables of this length may be found on large military platforms, this is approximately an order of magnitude longer than typical cables on GSFC platforms. This will be discussed further in the following subsections.

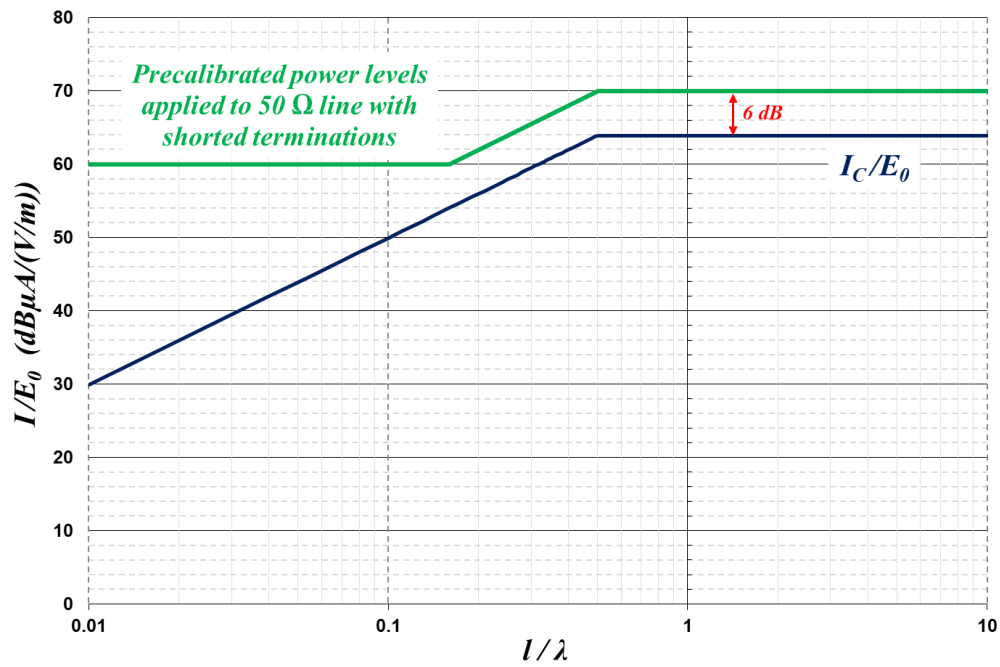

Figure 2.5-73.  $I/E_0$  with Precalibrated Levels Applied to Shorted 50  $\Omega$  Line

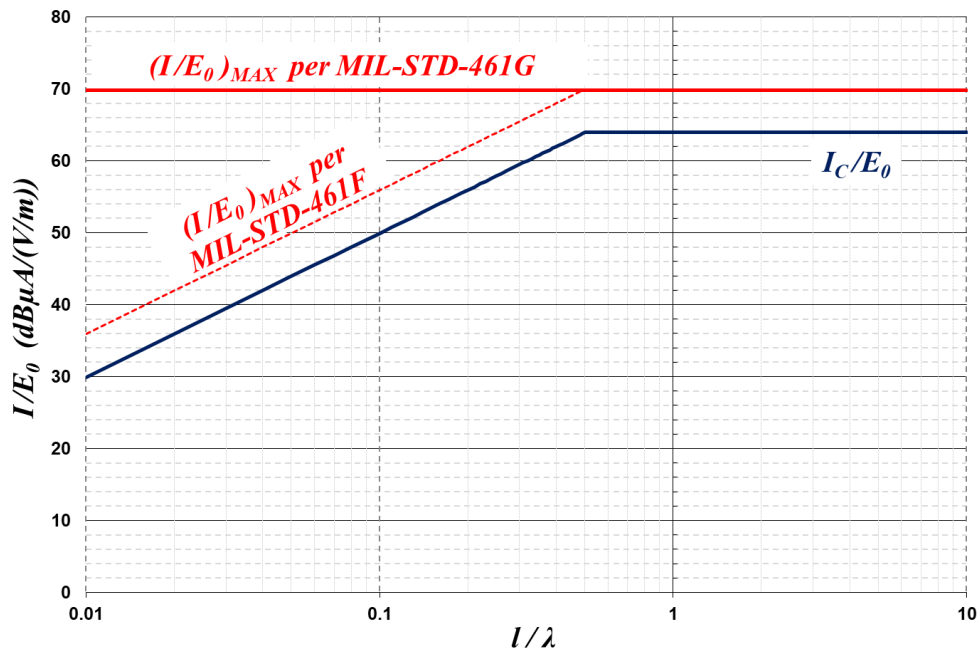

Figure 2.5-74.  $(I/E_0)_{MAX}$  per MIL-STD-461F and MIL-STD-461G

Check the GSFC Technical Standards Program website at <http://standards.gsfc.nasa.gov> or contact the Executive Secretary for the GSFC Technical Standards Program to verify that this is the correct version prior to use.

### 2.5.3.3.6.1.2 Pre-calibration

The purpose of the pre-calibration step is to create a lookup table that records the forward drive level at each frequency required to establish the calibration current in a standard calibration fixture as specified in MIL-STD-461G. These levels are not to be exceeded during injection into a cable under test (CUT).

The general concept is similar to the pre-calibration step for CS101 as discussed in section 2.5.3.3.4.7. Because CS101 is defined as voltage injection, the purpose of the pre-calibration step is to establish a short-circuit current limit. Because CS114 is defined as current injection, the purpose of the pre-calibration step is to establish an open-circuit voltage limit.

In the pre-calibration setup specified by MIL-STD-461, one end the fixture is terminated in a 50  $\Omega$  coaxial load, and the other end is connected to the 50  $\Omega$  input of the measurement device. From a loop circuit standpoint, the two 50  $\Omega$  loads are in series, providing a total loop impedance of 100  $\Omega$ . Measurement of induced current in the fixture is performed by measuring the voltage across the 50  $\Omega$  input of the measurement device. Therefore, the total drive voltage injected into the fixture is actually 2x (6 dB higher) than that being measured. More information about the pre-calibration step is provided in the MIL-STD-461G Application Guide.

In many cases, the setup can be substantially simplified from that specified in MIL-STD-461G. Figure 2.5-75 shows a simplified setup that may be used in a development laboratory for early diagnostic testing, and which is for many situations equally effective. In this simplified setup, the drive level is simply the signal generator setting at each frequency that is needed to establish the required current as read by the spectrum analyzer. Just as with the full setup, these signal generator settings are maximum values to be applied at each frequency.

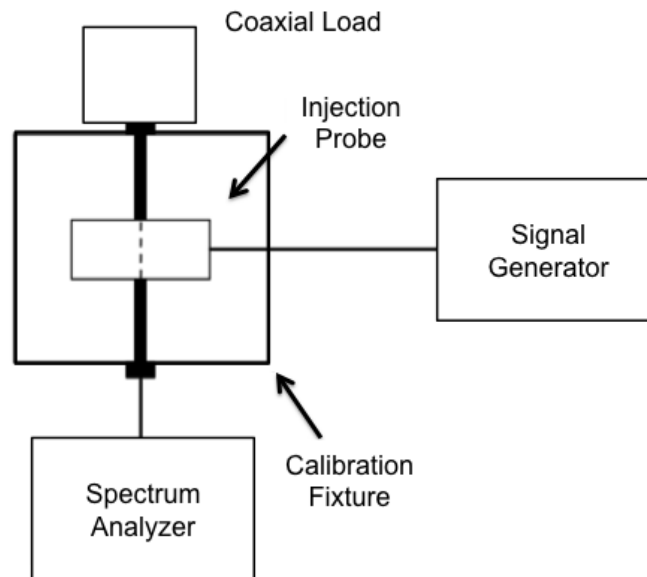

**Figure 2.5-75. Simplified CS114 Calibration Diagram**

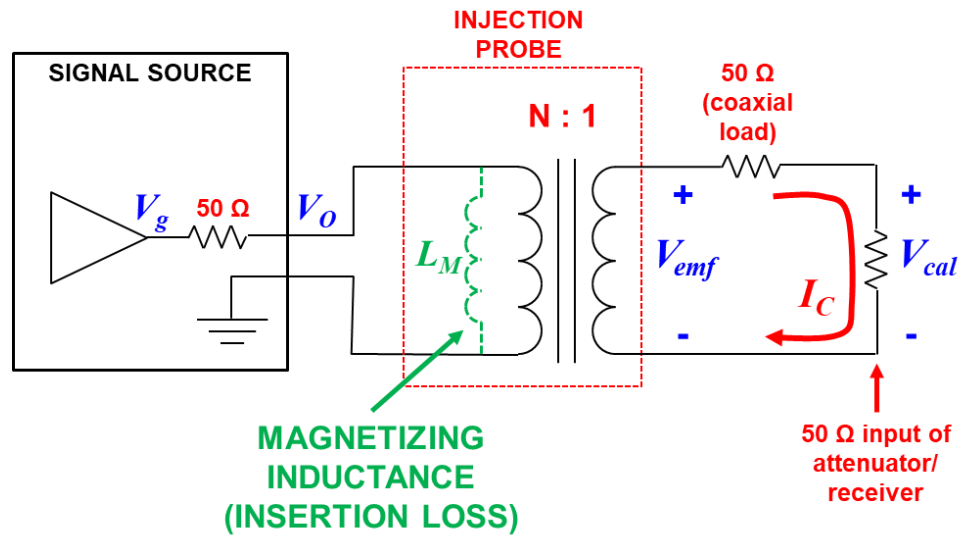

Figure 2.5-76. CS114 Pre-Calibration Equivalent Circuit

An equivalent circuit for the CS114 pre-calibration setup is shown in Figure 2.5-76.

The injection probe acts as a coupling transformer as shown in the figure. The secondary consists of the cable under test through the probe aperture; thus, the secondary consists of only one winding. The injection probe input may have one or more windings, depending on the manufacturer and model. The number of windings  $N$  will determine the effective source impedance of the injection circuit, the implications of which are discussed in the next section.

MIL-STD-461G specifies a maximum and recommended minimum insertion loss associated with the CS114 injection probe. This insertion loss in practice manifests itself primarily as a shunt magnetizing inductance  $L_M$ , as shown in the figure. The value of  $L_M$  can be estimated from the insertion loss curve. The typical insertion loss curves shown in MIL-STD-461G show a “knee” at approximately 1 MHz. This knee occurs when the inductive reactance,  $2\pi fL_M$ , is equal to  $50\ \Omega$ . Thus, a typical value for  $L_M$  is approximately  $8\ \mu\text{H}$ .

As shown in Figure 2.5-76, the calibration current  $I_C$  induces a calibration potential  $V_{cal}$  across the  $50\ \Omega$  input impedance of the measurement device:

$$V_{cal} = I_C \cdot 50\ \Omega$$

From a loop circuit standpoint, the  $50\ \Omega$  input of the measurement device is in series with the  $50\ \Omega$  coaxial (dummy) load on the other side of the calibration fixture, providing a total loop impedance of  $100\ \Omega$ . For this reason, the measured potential  $V_{cal}$  is half of the total potential  $V_{emf}$  induced in the calibration fixture:

$$V_{emf} = 2 \cdot V_{cal} = 2 \cdot I_C \cdot 50\ \Omega$$

$$I_C = \frac{V_{emf}}{100\ \Omega}$$

As shown in Figure 2.5-72, the corner frequency for the high frequency asymptote occurs when  $l = \lambda/2$ . The CS114 curves specified in MIL-STD-461G show the corner frequency at 1 MHz, which corresponds to a cable length of 150 meters. While cables of this length may be found on large military platforms, this is approximately an order of magnitude longer than typical cables on GSFC platforms. However, the shape of the precalibrated current curve is also determined by the characteristics of the injection probe. This will be discussed in the next section.

The shape of the curve in Figure 2.5-71, and the shape of the CS114 curves specified in MIL-STD-461G, only apply to the current injected into the calibration fixture with a constant loop impedance of 100  $\Omega$ . As with true field to wire coupling discussed in the next section, the induced current in a real cable under test (CUT) will be determined by a combination of the impedance of the loop formed by the cable and the ground plane and the source impedance of the injection circuit.

#### 2.5.3.3.6.1.3 Injection Onto Cable Under Test (CUT)

First, it is important to understand that for any signal source (signal generator, amplifier, etc.) intended to operate in a 50  $\Omega$  system, the displayed value for the output potential (labelled  $V_O$  in Figure 2.5-76) assumes that the output is connected to a 50  $\Omega$  load. Because a real CUT will not necessarily present a 50  $\Omega$  load, this displayed value for  $V_O$  is not meaningful for the purposes of circuit analysis. The more meaningful parameter is  $V_g$ , the potential on the “upstream” side of the 50  $\Omega$  source impedance of the signal source, as shown in Figure 2.5-76. This is the potential that will be applied to an open circuit, and it is always 2x (6 dB) higher than the displayed output potential  $V_O$ :

$$V_g = 2V_O$$

$$(V_g)_{dB} = (V_O)_{dB} + 6 \text{ dB}$$

In the following analysis,  $V_g$  is the parameter that will be used.

The Thévenin equivalent circuit for CS114 injection onto a real CUT is shown in Figure 2.5-77. The source impedance  $Z_S$  mapped to the secondary is  $1/N^2$  multiplied by the parallel combination of  $L_M$  and the 50  $\Omega$  output impedance of the signal source:

$$Z_S = \frac{1}{N^2} \cdot \frac{(50 \Omega)(j\omega L_M)}{50 \Omega + j\omega L_M}$$

where  $N$  is the number of turns on the injection probe input. For most typical probes,  $N$  has a value of either 1 or 2. Representative curves for  $N = 1$  and  $N = 2$  are shown in Figure 2.5-78. In both cases, magnetizing inductance dominates below the knee frequency and the 50  $\Omega$  source impedance dominates above the knee. Note that for  $N = 2$ , the entire curve shifts down by a factor of 4 ( $1/N^2$ ), and the high frequency asymptote is 12.5  $\Omega$ .

Ignoring any additional loss in the injection probe beyond  $L_M$ , the open-circuit potential at the output of the probe,  $(V_{emf})_{OC}$ , is the potential required to establish the calibration current  $I_C$  through the 100  $\Omega$  impedance in the calibration fixture in series with  $Z_S$ :

$$(V_{emf})_{OC} = I_C \cdot \sqrt{(100 \Omega)^2 + (Re[Z_S])^2 + (Im[Z_S])^2}$$

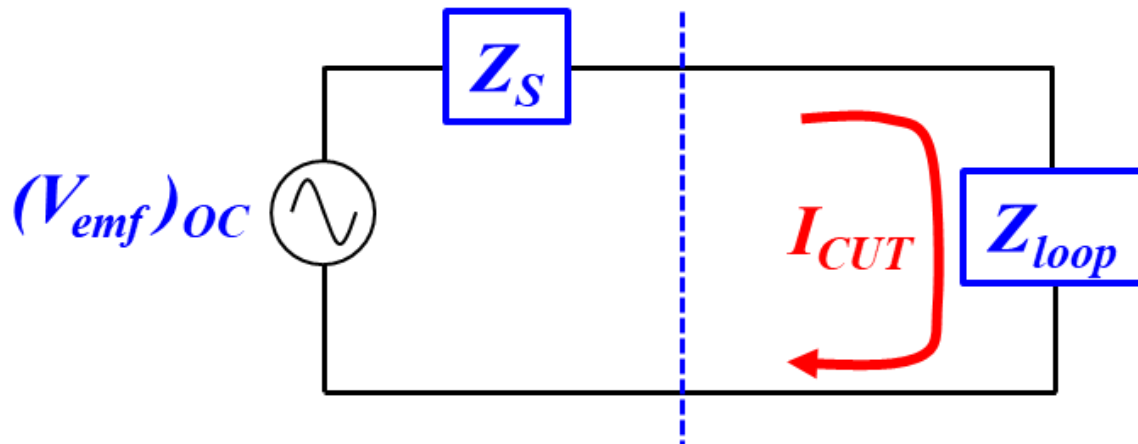

Figure 2.5-77. Thévenin Equivalent Circuit for CUT Injection

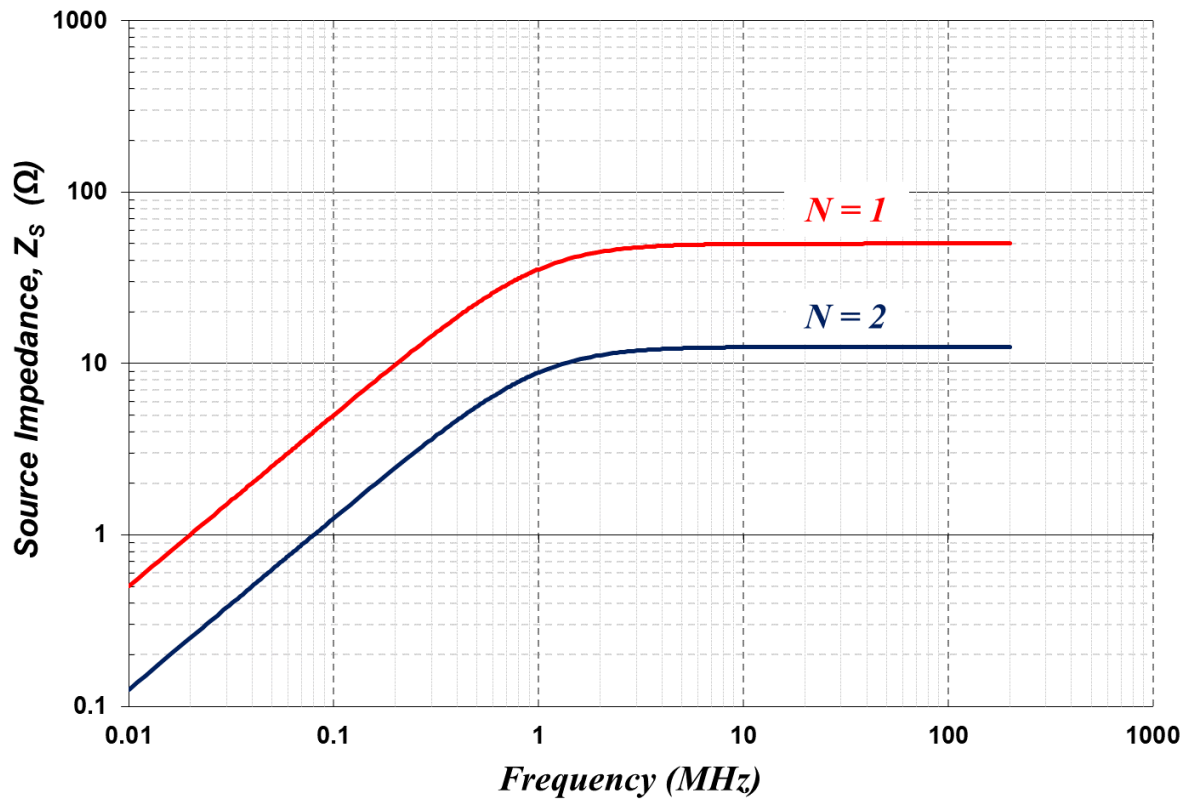

Figure 2.5-78. Representative  $Z_S$  for  $N = 1$  and  $N = 2$

Check the GSFC Technical Standards Program website at <http://standards.gsfc.nasa.gov> or contact the Executive Secretary for the GSFC Technical Standards Program to verify that this is the correct version prior to use.

Figure 2.5-78 shows representative curves for  $(V_{emf})_{OC}$  corresponding to the specified limit for  $I_C$  shown in Figure 2.5-21 for  $N = 1$  and  $N = 2$ . Because of the low source impedance below the knee frequency, the open-circuit potential is essentially independent of  $N$ . Even above the knee, the open-circuit potential does not vary significantly.

This is the maximum potential that can be injected into the CUT when its loop impedance goes to infinity (or in practical terms, when it is much greater than  $100 \Omega$ ). Thus, one of the primary purposes of the CS114 calibration step is to limit the open-circuit potential that may be injected into the loop at any given frequency to the precalibrated level determined for  $(V_{emf})_{OC}$ .

The short-circuit current that the injection circuit is capable of providing is given by:

$$(I_{CUT})_{SC} = \frac{(V_{emf})_{OC}}{Z_S}$$

Figure 2.5-79 shows representative curves for  $I_{SC}$  for  $N = 1$  and  $N = 2$  that correspond to the default limit for  $I_C$  along with the maximum injected current specified by MIL-STD-461G are also shown for reference.

Above the knee frequency in the  $I_C$  curve, the injection circuit is capable of providing the maximum current with sufficient headroom with either  $N = 1$  or  $N = 2$ . Below the knee frequency, the injection circuit can provide the maximum current with approximately 10 dB of headroom for  $N = 2$ ; it can just provide the maximum current with no headroom for  $N = 1$ .

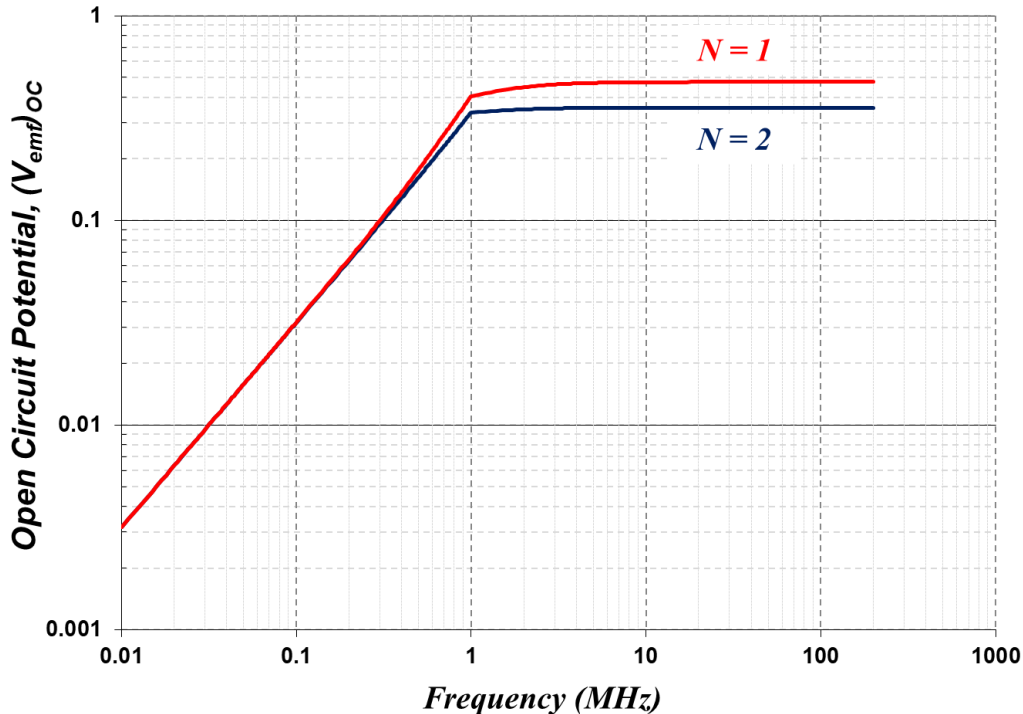
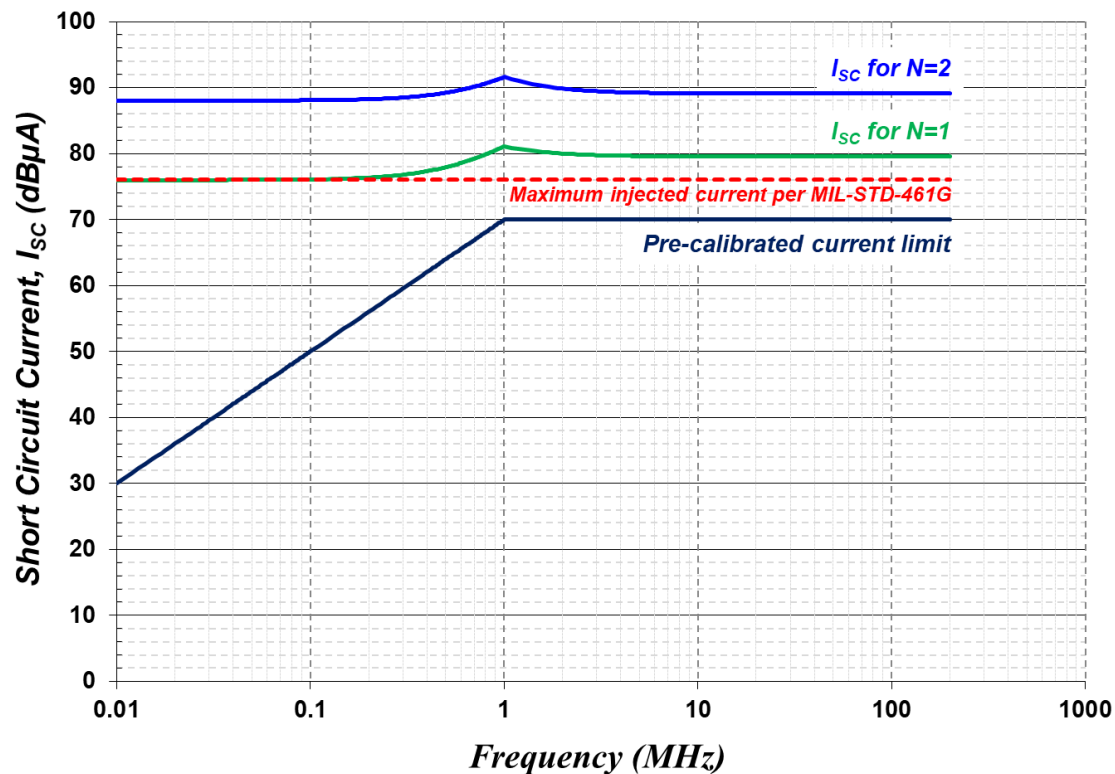

Figure 2.5-79. Representative  $(V_{emf})_{OC}$  for  $N = 1$  and  $N = 2$



**Figure 2.5-80. Representative  $I_{sc}$  for  $N = 1$  and  $N = 2$**

On GSFC platforms, a typical on-orbit RS103 level is 2 V/m as discussed in Section 2.5.2.4.2. This corresponds to a CS114 calibration limit of 3 mA, or 70 dBµA, on the plateau portion of the curve. This forms the basis for the GEVS limit shown in Figure 2.5-21 in the main body of the document. In addition to protecting against crosstalk, testing to these levels will demonstrate the ability of the victim cables to withstand typical on-orbit electric fields.

As previously stated, the knee frequency of 1 MHz corresponds to a default cable length of 150 meters, which is significantly longer than cables used on GSFC platforms. If CS114 is strictly considered as a low frequency substitute for RS103, it would appear that these curves are not an ideal fit and should be tailored.

If implemented, such tailoring would include the following items:

- 1) The knee frequency should be increased to be consistent with typical cable lengths used on GSFC platforms, e.g. 15 meters, which is  $\lambda/2$  at 10 MHz.
- 2) The injected frequency at low frequencies (when cable is electrically short) would be adjusted to be consistent with the low frequency plateau shown in Figure 2.5-73.

However, the greater concern on GSFC platforms at lower frequencies is cable-to-cable crosstalk. For this reason, GEVS applies the MIL-STD-461G approach in order to apply a constant injected current limit of 70 dBµA across the frequency range as a more effective means of establishing immunity to crosstalk against the limit for Common Mode Conducted Emissions (CMCE) discussion in section 2.5.2.1.2.

Check the GSFC Technical Standards Program website at <http://standards.gsfc.nasa.gov> or contact the Executive Secretary for the GSFC Technical Standards Program to verify that this is the correct version prior to use.

### 2.5.3.3.6.2 Conducted Susceptibility, Power Leads, 150 kHz to 50 MHz

The basic engineering concern of this test is the need to evaluate the conducted susceptibility of equipment to ripple on its primary power inputs. For this purpose, MIL-STD-461C and MIL-STD-462 defined CS01 for low frequencies (< 50 kHz) and CS02 for high frequencies (> 50 kHz).

With the release of MIL-STD-461D in 1993 and continuing through -461E (1999) and -461F (2007), CS01 was replaced with CS101. CS101 is nearly identical to CS01 except that it goes up to 150 kHz and that it requires a higher power amplifier than CS01. CS02 was discontinued in MIL-STD-461D and all subsequent versions.

MIL-STD-461D and later versions specify the CS114 test method for evaluating conducted susceptibility on power lines at frequencies above 150 kHz. CS114 is primarily intended to evaluate susceptibility of bulk cables (power and signal) to common mode currents, but it is also intended for injection of current onto power leads as stated in MIL-STD-461G Section 5.13.3.4.c:

“Also perform the procedures on power cables with the power returns and chassis grounds (green wires) excluded from the cable bundle. For connectors which include both interconnecting leads and power, perform the procedures on the entire bundle, on the power leads (including returns and grounds) grouped separately, and on the power leads grouped with the returns and grounds removed.”

The default CS02 limit was defined as a swept sinusoid with an amplitude of 1 V<sub>rms</sub>, delivered from a 50 Ω source from 50 kHz to 400 MHz. The voltage injection method is functionally equivalent to the CS02 method with the capacitive coupler replaced with the inductive injection probe. If using the voltage injection method, it is necessary to define a short-circuit current limit in order to limit the current that may be injected into the EUT. If using the direct current monitoring method of CS114, it is necessary to convert the CS02 voltage limit into a current limit as discussed below.

A thorough comparison of the CS114 and CS02 test methods is provided in the GEVS application note entitled, “CS114 vs. CS02 – Conducted Susceptibility,” available on the “GEVS Application Notes” page of the GSFC EMC Working Group SPACES site:

<https://spaces.gsfc.nasa.gov/display/EMCWG/GEVS+Application+Notes>

As stated in the “Precalibration” section, the precalibration determines the open-circuit potential that may be injected into the CUT, which in this case is the primary power lead to the EUT.

If using the voltage monitor method, the injected potential will be limited to 1 V<sub>rms</sub> across the entire frequency range.

For the current monitor method, Figure 2.5-81 shows representative curves for  $(V_{emf})_{OC}$  corresponding to the specified limit for  $I_C$  on power lines shown in Figure 2.5-23 for  $N = 1$  and  $N = 2$ . Because of the low source impedance below the knee frequency, the open-circuit potential is essentially independent of  $N$ . Above the knee, the open-circuit potential is approximately 1.12 V for  $N = 1$  and 1.5 V for  $N = 2$ , corresponding to the respective values of  $Z_S$  of 12.5 Ω and 50 Ω combined with the 100 Ω impedance in the calibration fixture.

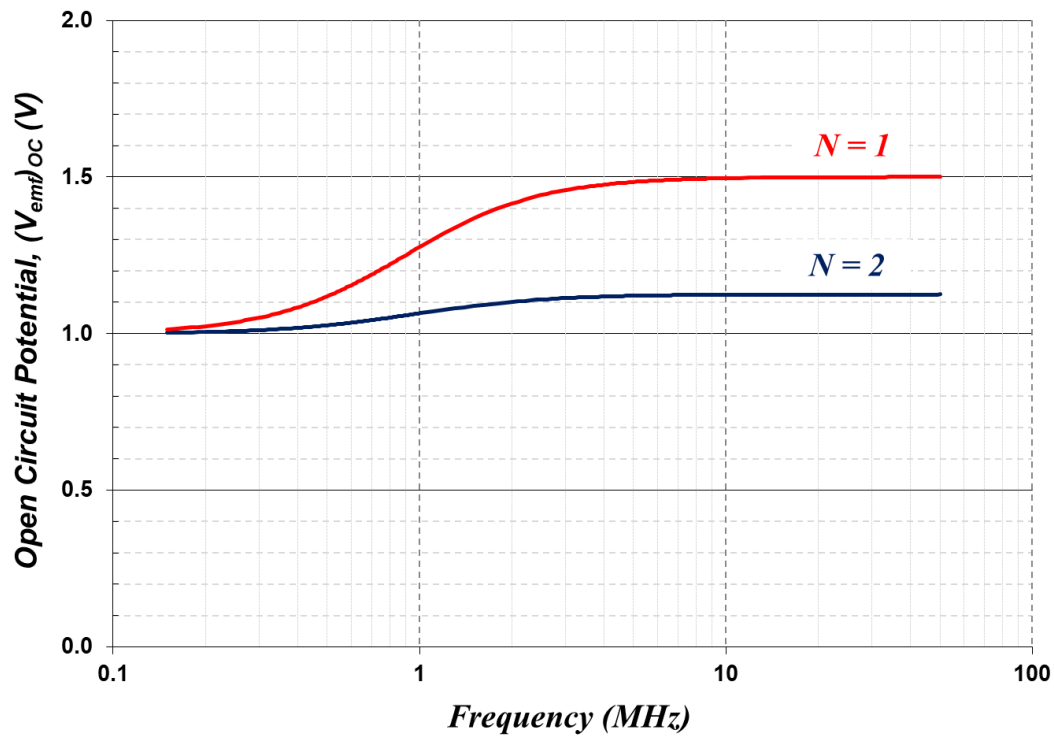

Figure 2.5-81. Representative  $(V_{emf})_{OC}$  for  $N = 1$  and  $N = 2$

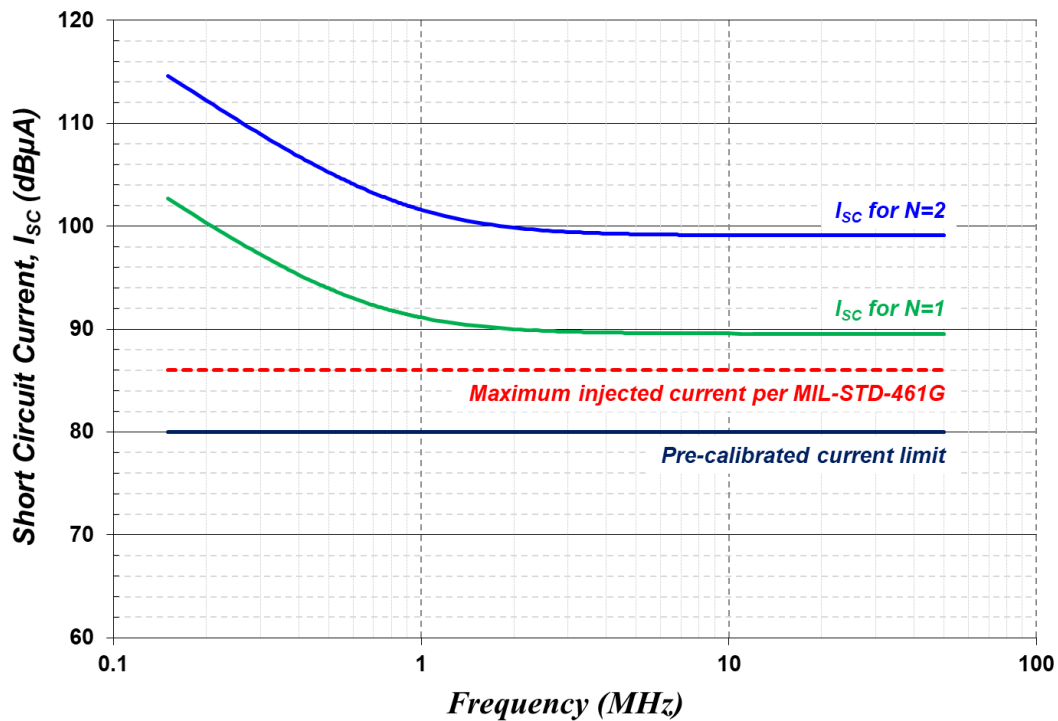

Figure 2.5-82. Representative  $I_{sc}$  for  $N = 1$  and  $N = 2$

Check the GSFC Technical Standards Program website at <http://standards.gsfc.nasa.gov> or contact the Executive Secretary for the GSFC Technical Standards Program to verify that this is the correct version prior to use.

Figure 2.5-82 shows representative curves for  $I_{SC}$  for  $N = 1$  and  $N = 2$ . If the restriction is removed to limit the current to 6 dB higher than the pre-calibrated current, these curves show the amount of current that is available to inject into a low impedance.

As long as the injected levels are limited to the precalibrated forward power levels,  $I_{SC}$  will be limited to levels shown in Figure 2.5-78. In the event that software controls do not properly limit the drive level, it is still good practice to monitor the injected current in real time and limit it to the appropriate level for  $I_{SC}$  as an additional safeguard.

If using the direct current monitor method, the common mode injection on the power leads MUST be performed first. Due to the nature of injecting on individual power leads as described above, the injection is a combination of common mode and differential mode. If susceptibilities are observed at the same frequencies and with similar signatures to those observed during common mode injection, then they are likely common mode susceptibilities. If different susceptibilities are observed, they are likely differential mode susceptibilities and may be addressed accordingly.

Direct differential mode injection was considered in order to be consistent with the direct differential mode measurements of conducted emissions. Because the injection probe acts as a transformer, the differential mode configuration, with both high and return leads running through the probe, configures it as a 1:2 transformer. This alters the relationship of the source impedance of the injection circuit to the load impedance of the EUT. This impedance relationship is essential for defining the short-circuit current and open-circuit potential of the injection circuit, which is the entire purpose of the pre-calibration step. While differential mode injection is a good idea in principle, it was determined that it introduced unnecessary complications to the test setup. Single line injection on each power lead is recommended as a suitable compromise. In this respect, it is similar to the CS02 test method, which was line-to-ground injection and was performed on each individual power lead as well.

The upper frequency limit is set to 50 MHz in order to be consistent with the upper frequency limit for the conducted emissions tests. This allows the injection probe to be placed up to 60 cm ( $\lambda/10$  at 50 MHz) from the EUT instead of the default 10 cm specified by MIL-STD-461G.

### 2.5.3.3.7 Radiated Emissions, Electric Field

#### 2.5.3.3.7.1 Frequency Range

The basic limit and test method of MIL-STD-461G RE102 apply while incorporating the following tailoring guidelines in section A.5.17 of the MIL-STD-461G Application Guide:

- “The limits could be adjusted based on the types of antenna-connected equipment on the platform and the degree of shielding present between the equipment, associated cabling, and the antennas. For example, substantial relaxations of the limit may be possible for equipment and associated cabling located totally within a shielded volume with known shielding characteristics.”
- “It may be desirable to tailor the frequency coverage of the limit to include only frequency bands where antenna-connected receivers are present.”

The RE102 limit specifies the full range of frequencies used by antenna-connected receivers on military platforms; not all of these frequencies are used on NASA platforms. Most GSFC spacecraft do not use the electromagnetic spectrum below 2 GHz for the purpose of receiving RF signals. A default low frequency limit of 200 MHz has been selected for radiated emission control on GSFC platforms for the following reasons:

- Control of conducted emissions at ultra-high frequencies (UHF) is problematical. While shield room radiated measurements are notoriously inaccurate, UHF conducted emissions measurements are not going to be much better unless the absorbing clamp is used. Because it cannot be guaranteed that the absorbing clamp will be used in all cases, a radiated technique is preferred. In addition, above 400 MHz, equipment case leakage may be as significant as radiation from the interconnecting cables.
- Many satellites use the Global Positioning System (GPS). While this doesn't drive RE control down to 200 MHz, it does require control down to 1 GHz.
- All launch platforms require strict control of the command destruct signal band around 400 MHz. While many portions of a GSFC satellite may be powered off during the ascent portion of a mission, any that need to be powered will have to meet the stringent command destruct band RE limit. Therefore, RE control at 400 MHz is required.
- 200 MHz is a convenient breakpoint in the RE102 test method between different antenna types.

For all of the reasons given above, the RE102 test method will apply between 200 MHz to 18 GHz with the limit shown in Figure 2.5-27. The figure includes a representative notch for the S-band receiver (1.7-2.3 GHz), which should apply to most GSFC platforms. For equipment that is powered on at launch, notches may also be applied to protect receivers on the launch vehicle and at the launch site. Figure 2.5-27 also includes a representative notch for the Launch Vehicle Command Destruct receiver (420-480 MHz). These notches, and any other applicable notches for other receivers, must be tailored for the specific receiver frequency ranges and sensitivity levels on the platform. In each notch, the measurement bandwidth that simulates the protected receiver must be used instead of the MIL-STD-461G prescribed bandwidth that would normally be used in that band.

Further guidance relevant to Launch Vehicle & Launch Site Electromagnetic Environments can be found in the following documents:

- ELVL-2010-0042300 Electromagnetic Environments – A guideline for Spacecraft launching from Eastern, Western and Pacific Ranges

Emissions below 200 MHz are addressed by the Common Mode Conducted Emissions (CMCE) test on power and signal cables defined in Section 2.5.2.1.2. The purpose of that test is to control cable-to-cable crosstalk while at the same time eliminating the paperwork associated with waivers against an inapplicable and unnecessarily stringent RE102 limit below 200 MHz. The CMCE test is adapted from the alternate RE102 test methods defined in SL-E-0002, Space Shuttle Specification, Electromagnetic Interference Characteristics, Requirements for Equipment.

An extensive discussion of the relationship between conducted and radiated emissions is provided in the GEVS application note entitled, “Radiated Emissions as a Function of Common Mode Current,” available on the “GEVS Application Notes” page of the GSFC EMC Working Group SPACES site:

<https://spaces.gsfc.nasa.gov/display/EMCWG/GEVS+Application+Notes>

The guidance above should apply to most GSFC platforms. However, if any equipment on the platform uses the electromagnetic spectrum below 200 MHz, then a radiated emission limit must be imposed at those frequencies, and the corresponding RE102 test methods of MIL-STD-46G should be applied. In addition, the antenna used for the measurement should simulate that used on the platform.

#### 2.5.3.3.7.2 Antennas

The MIL-STD-461G RE102 test procedure specifies the use of double ridge horn antennas between 200 MHz and 18 GHz. Additional options include the log-spiral or log periodic antenna. Although conical log spiral antennas are discouraged in MIL-STD-461G, they are permitted on GSFC platforms because they offer some advantages in certain applications as discussed below.

The double ridge horn has a constant aperture. This means the gain increases with frequency, which translates to a decreased field-of-view as frequency increases. The log-spiral and log periodic antennas have a lower and constant gain as a function of frequency, which translates into a wider and more constant field of view. For these reasons, the log-spiral and log periodic antennas are better suited to capture all of the radiated emissions from a given test setup using fewer antenna positions, Thus, reducing total test time. This can be a particularly significant advantage when performing a radiated emissions test on a larger test article such as an integrated instrument, payload, or spacecraft, when costs for test time are significantly higher due to “marching army” costs.

The log-spiral antennas offer similar advantages for radiated susceptibility testing, as discussed in section 2.5.3.3.8.

A few notes regarding log-spiral antennas:

- Log-spiral antennas are circularly polarized, which means their response to a linearly polarized field is 3 dB down from what it is for the proper circular polarization. This must be addressed in one of two ways: 1) applying a -3 dB correction factor to the test configuration, or 2) subtracting 3 dB from the nominal limit.
- The wide field-of-view (low gain) and circular polarization enable most measurements to be completed using only one position and one polarization.
- The log-spiral antenna only works up to 10 GHz; the double ridge horn must be used for measurements above 10 GHz.
- The low gain of the log-spiral antenna may not have the required sensitivity in the notches, depending on the level of the notch. If so, it is recommended that a basic sweep be performed using the log-spiral, then go back and scan the notch frequencies with the double ridge horn.

#### 2.5.3.3.7.3 Antenna Positions and “Spot Sizes”

MIL-STD-461G specifies the following for RE102 antenna positions:

- For testing from 200 MHz up to 1 GHz, place the antenna in a sufficient number of positions such that the entire area of each EUT enclosure and the first 35 cm of cables and leads interfacing with the EUT enclosure are within the 3 dB beamwidth of the antenna.
- For testing at 1 GHz and above, place the antenna in a sufficient number of positions such that the entire area of each EUT enclosure and the first 7 cm of cables and leads interfacing with the EUT enclosure are within the 3 dB beamwidth of the antenna.

From the above, it is clear that emissions from the interconnect cables are being measured along with emissions from the EUT enclosure itself. ALL CABLES CONNECTING TO THE EUT ARE CONSIDERED PART OF THE TEST ARTICLE.

In order to optimize the number of antenna positions for a given test configuration, it is necessary to determine the area of the EUT that is “seen” by the antenna at a given location. This “seen” area is commonly called the “spot size.”

The spot size is determined by the 3 dB (half power) beamwidth,  $\theta_{3dB}$ , of the test antenna. It is generally a function of frequency and may be specified in the manufacturer’s datasheet as a curve or family of curves. When such curves are provided, the minimum value over the frequency range of interest may be taken directly from the datasheet.

The value of  $\theta_{3dB}$  is always defined as the end-to-end span of the beam as shown in Figure 2.5-83. In order to calculate the diameter of the spot size, what is needed is the angle from boresight to the edge of the beam, which is given by  $\theta_{3dB}/2$ . Thus, for a test antenna placed at a distance  $r$  from the EUT, the diameter  $D$  of the spot seen by the antenna is given by:

$$D = 2r \tan\left(\frac{\theta_{3dB}}{2}\right)$$

For standard RE102 measurements,  $r = 1$  meter.

An antenna with a minimum  $\theta_{3dB}$  of 30 degrees in a given frequency range of interest will have a spot size with a minimum diameter of 52 cm.

An antenna with a minimum  $\theta_{3dB}$  of 60 degrees in a given frequency range of interest will have a spot size with a minimum diameter of 1.15 m.

Knowledge of spot sizes for each test antenna will allow the test engineer to select an optimal number of antenna positions in order to provide sufficient coverage of the EUT and interconnect cables while making most efficient use of test time.

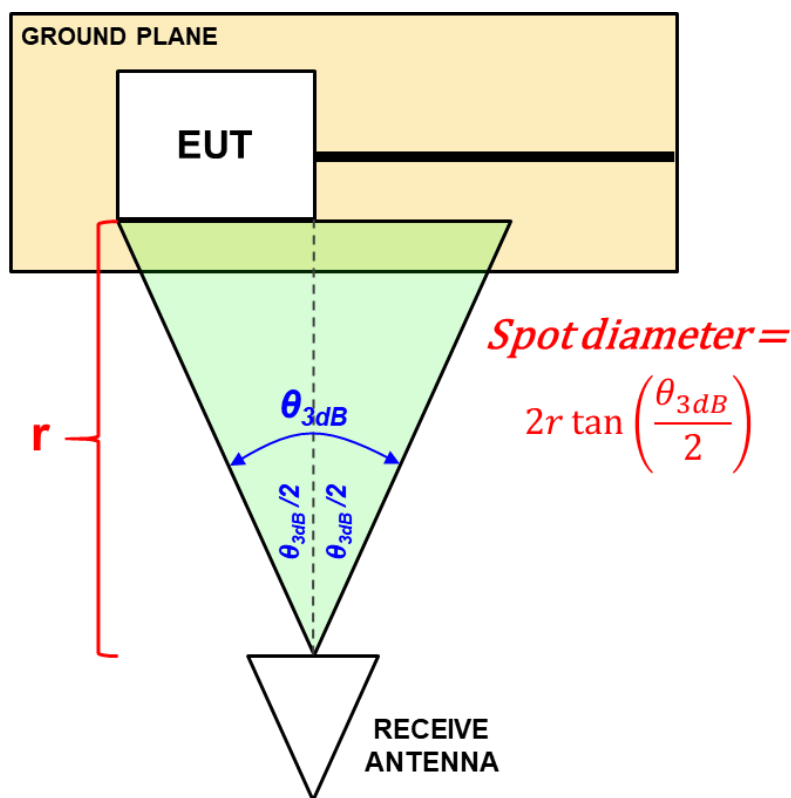

Figure 2.5-83. RE "Spot Size" Calculation

#### 2.5.3.3.7.4 Notches

As stated in MIL-STD-461, the purpose of the RE102 requirement is to protect sensitive receivers from interference coupled through the antennas associated with the receiver. Some platforms specify notches to protect specific receivers that are sensitive to levels that are lower than the default RE102 limit. The purposes of this section are to 1) provide guidance for defining meaningful limits that may be measured within the constraints of available technology, and 2) to indicate strategies for measuring to such low limits.

##### 2.5.3.3.7.4.1 Designing a Notch

The theoretical noise power in Watts delivered by a thermal source into an impedance matched load is:

$$P_N = k_B T B$$

where:

$k_B$  = Boltzmann's constant =  $1.38 \times 10^{-23}$  J/K  
 $T$  = temperature, K  
 $B$  = bandwidth, Hz

When defining the noise floor of a piece of measurement equipment, a standard reference temperature of  $T = 290$  K is used. In this case,  $k_B T = 4 \times 10^{-21}$  W/Hz =  $-174$  dBm/Hz.

Thus,

$$(P_N)_{dB} = -174 \text{ dBm/Hz} + 10 \log_{10} B$$

In a  $50 \Omega$  system (typical for RF receiver inputs), the potential in dB $\mu$ V across the  $50 \Omega$  resistor is 107 dB higher than the power in dBm. Therefore, the equivalent broadband thermal voltage noise  $V_N$  in a  $50 \Omega$  system is:

$$(V_N)_{dB} = -67 \text{ dB}\mu\text{V}/\sqrt{\text{Hz}} + 10 \log_{10} B$$

The equations above represent the theoretical minimum broadband noise floor of the measurement system for a given measurement bandwidth. Even when all other sources of noise are eliminated, the noise floor cannot be reduced any lower than this.

The noise floor may be further converted to an equivalent minimum measurable electric field level in dB $\mu$ V/m using the antenna factor (AF):

$$E(\text{dB}\mu\text{V}/\text{m}) = V_{NF} + AF(\text{dB}/\text{m})$$

The antenna factor is the reciprocal of the antenna's effective height  $h_e$ , which is, by definition, equal to the ratio of the received potential  $V$  to the incident electric field  $E$ :

$$h_e = \frac{V}{E}$$

The effective height may be derived from the effective aperture  $A_e$ , which is given by:

$$A_e = \frac{G \lambda^2}{4\pi} = \frac{G c^2}{4\pi f^2}$$

However,  $A_e$  is, by definition, the ratio of the received power  $P$  to the incident power density  $P_D$ .

For a  $50\ \Omega$  receiver input:

$$P = \frac{V^2}{50\ \Omega}$$

For an incident plane wave in free space with electric field  $E$ :

$$P_D = \frac{E^2}{120\pi}$$

Thus,

$$A_e = \frac{Gc^2}{4\pi f^2} = \frac{P}{P_D} = \frac{(V^2/50\ \Omega)}{E^2/120\pi}$$

$$\frac{V^2}{E^2} = \frac{50Gc^2}{480\pi^2 f^2}$$

$$h_e = \frac{V}{E} = \frac{c\sqrt{G}}{9.73f}$$

$$AF = \frac{1}{h_e} = \frac{9.73f}{c\sqrt{G}}$$

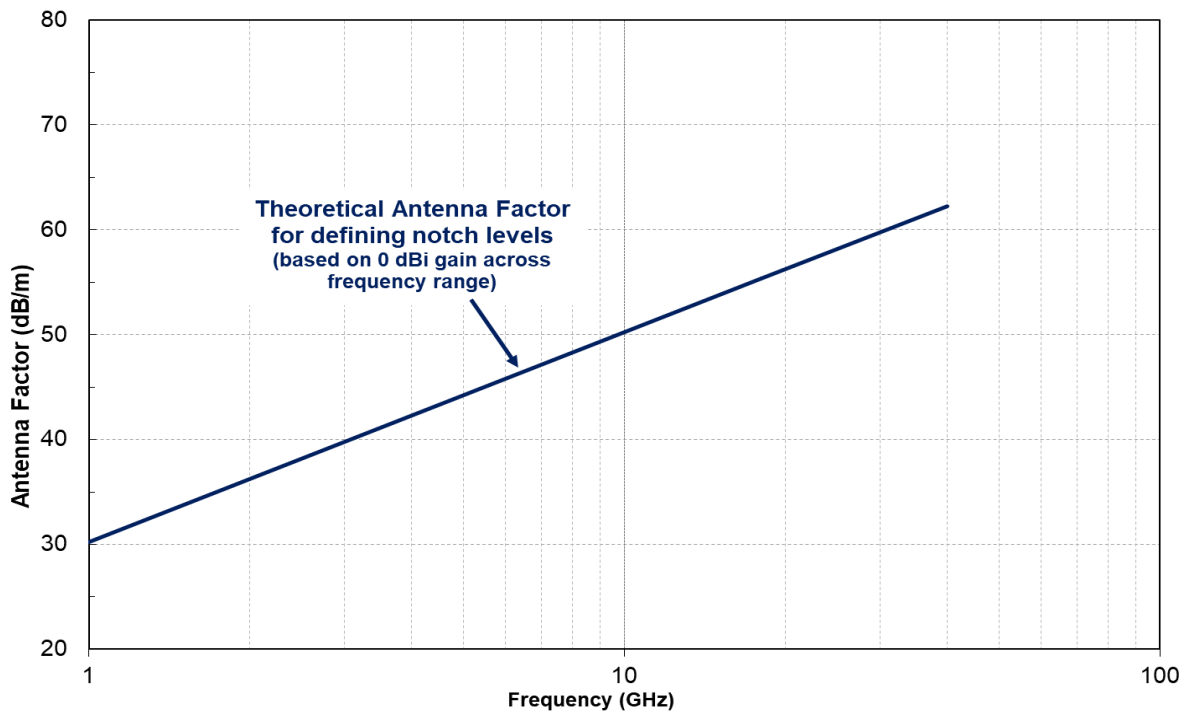

**Figure 2.5-84. Side and Back Lobe Antenna Factor**

Check the GSFC Technical Standards Program website at <http://standards.gsfc.nasa.gov> or contact the Executive Secretary for the GSFC Technical Standards Program to verify that this is the correct version prior to use.

Using  $c = 0.3 \times 10^9$  m/s, expressing  $f$  in GHz, and converting to dB gives:

$$AF(dB/m) = 30.22 + 20 \cdot \log_{10} f_{GHz} - G(dBi)$$

When defining an RE102 notch limit to apply to neighboring equipment to protect the receiver, the gain in the antenna's main lobe should not be used in the above equation. Unintentional radiated emission sources are always located in side or back lobes. A conservative worst-case value for gain in side or back lobes is 0 dBi (unity); this is the value of  $G(dBi)$  that should be used in the equation above. When the antenna pattern is omnidirectional, or nearly so, and there is no pronounced main beam vs. back lobes, then it is not possible to place electronics completely out of the "main" beam of the receiving antenna. In this case, the appropriate omni or near omni gain should be used for  $G(dBi)$ . The theoretical antenna factor from 1 – 18 GHz, assuming  $G = 0$  dBi across the frequency range, is shown as the solid blue curve in Figure 2.5-84.

The side/back lobe antenna factor in Figure 2.5-84 combined with the theoretical average thermal noise floor leads to the family of curves in Figure 2.5-85 for noise equivalent electric field as a function of measurement bandwidth. The figure also shows the default RE102 limit with notional notches for comparison. All of these curves are normalized to a noise figure of 0 dB (discussed in the next section) and apply the theoretical antenna factor that assumes an antenna gain of 0 dBi across the frequency. In addition, negligible cable loss is assumed.

The main purpose of Figure 2.5-85 is to provide guidance in defining meaningful notch limits that correspond to the operating bandwidth of the victim radio that is being protected. Consider the default S-band notch at 2025 – 2120 MHz. The figure shows that the displayed 20 dBuV/m limit is commensurate with a receiver whose bandwidth is below 100 kHz. However, if the measurement receiver operates with a bandwidth of 100 kHz or more, this limit would not be realistic and the error in the limit definition must be investigated and corrected.

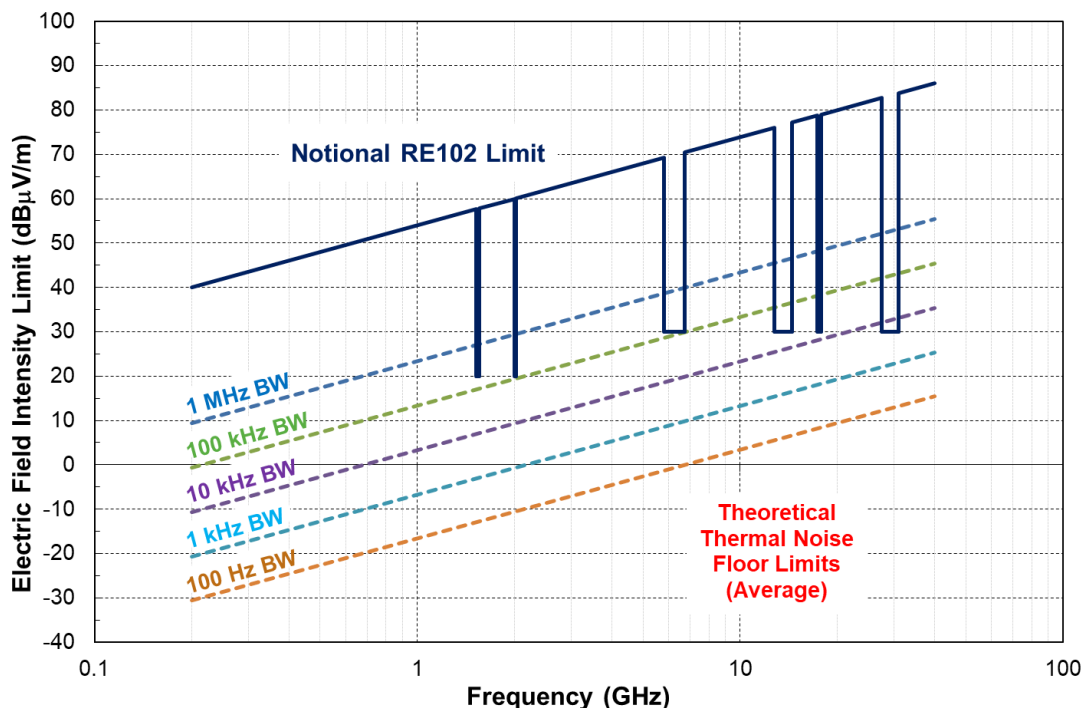

**Figure 2.5-85. Theoretical Noise Floor Limits Considering Average Thermal Power**

Check the GSFC Technical Standards Program website at <http://standards.gsfc.nasa.gov> or contact the Executive Secretary for the GSFC Technical Standards Program to verify that this is the correct version prior to use.

#### 2.5.3.3.7.4.2 Instrumentation for Measuring a Low-level Notch Limit

The performance of a measurement system is governed by its noise factor  $F$ , which is defined as the linear (non-dB) ratio of the device's actual output noise floor to the theoretical thermal noise floor limit, with both quantities expressed in terms of power:

$$F = \frac{\text{Noise floor power}}{k_B T B}$$

$F$  is a departure from the ideal noise floor and is always greater than 1.

The noise figure (NF) is simply the noise factor expressed in dB. The device's noise floor is obtained by adding the specified NF to the theoretical thermal noise floor limit:

$$P_{NF} = -174 \text{ dBm/Hz} + 10 \log_{10} B + NF$$

$$V_{NF} = -67 \text{ dB}\mu\text{V}/\sqrt{\text{Hz}} + 10 \log_{10} B + NF$$

If the measurement receiver noise floor is too high to make the desired measurement, a low noise amplifier (LNA) between the antenna and receiver can lower the measurement system noise factor according to the equation:

$$F_{SYSTEM} = F_{LNA} + \frac{F_{RCVR}}{G_{LNA} - 1}$$

where  $F_{LNA}$  is the LNA noise factor,  $F_{RCVR}$  is the receiver noise factor, and  $G_{LNA}$  is the LNA gain. Note that all values are linear, i.e. not dB.

In order to minimize the contribution of the receiver's noise floor to the overall measurement system noise floor,  $G_{LNA}$  should be at least a factor of 10 (10 dB) higher than  $F_{RCVR}$ . However, care must be taken to avoid selecting a gain that is high enough to overload the front end of the measurement receiver.

The noise floor of EMI receivers and spectrum analyzers are typically expressed in terms of displayed average noise level (DANL). DANL is specified in dBm or dB $\mu$ V and normalized to a particular bandwidth  $B_0$ , which is typically 1 Hz or 10 Hz. From there, the noise floor at the actual measurement bandwidth may be scaled accordingly by adding  $10 \cdot \log_{10}(B/BP_0)$  to the specified value. The noise figure is simply the difference (in dB) between the noise floor and the theoretical noise floor limit.

It must be noted that the above discussion applies to the *average* thermal noise as a function of measurement bandwidth. MIL-STD-461 requires that *peak* detection be used for all frequency-domain emissions and susceptibility measurements. Peak detection will add 11 dB, the crest factor of thermal noise (discussed in section 2.5.3.3.7.5), to the average value:

$$V_{NF,Peak} = -67 \text{ dB}\mu\text{V}/\sqrt{\text{Hz}} + 10 \log_{10} B + NF + 11 \text{ dB}$$

It must be noted that DANL is generally specified with no front-end attenuation, while most manufacturers recommend 10 dB of attenuation in front of the mixer in order to obtain the desired voltage standing wave ratio (VSWR). This will raise the noise floor by another 10 dB. However, if an LNA is placed in front of the mixer, the 10 dB attenuation is not necessary.

This is best illustrated with the following numeric example. As of this writing, commercial EMI receivers have a typical DANL value of approximately -165 dBm, specified with 0 dB attenuation and normalized to a 1 Hz bandwidth. After adding the 11 dB crest factor, the actual noise floor is -154 dBm.

For  $B = 1$  Hz, the theoretical noise floor limit is equal to  $k_B T$ , which at  $T = 298$  K is equal to  $4 \times 10^{-21}$  W = -174 dBm. Thus, the receiver noise figure in this frequency range is -154 dBm – (-174 dBm) = 20 dB. In this example,  $G_{LNA}$  should be at least 30 dB in order to minimize the contribution of the receiver to the system noise floor.

If average detection is used, the noise figure is -165 dBm – (-174 dBm) = 9 dB. In this case, a  $G_{LNA}$  of 20 dB should be sufficient.

RE102 measurements are made using standard antennas with either antenna factor or gains specified by the manufacturer. The antenna factor is added to the noise floor in order to determine the “noise equivalent electric field” capability of the measurement system. MIL-STD-461 requires the use of a double ridge guide horn above 200 MHz. From 1 – 18 GHz, the antenna factor for the DRG specified in MIL-STD-461 is closely approximated by the dashed red line in Figure 2.5-86. While MIL-STD-461 RE102 doesn’t control emissions above 18 GHz, a reasonable extrapolation of its intent above 18 GHz is another DRG of similar gain as at lower frequencies. The antenna factor for such an antenna is closely approximated by the green dashed curve in Figure 2.5-86.

The typical DRG antenna factors in Figure 2.5-86 combined with the theoretical peak thermal noise floor leads to the family of curves in Figure 2.5-87 for noise equivalent electric field for the measurement system. Again, all of these curves are normalized to a noise figure of 0 dB, negligible cable loss is assumed, and they are compared to the default RE102 limit with the same notional notches as in the previous example.

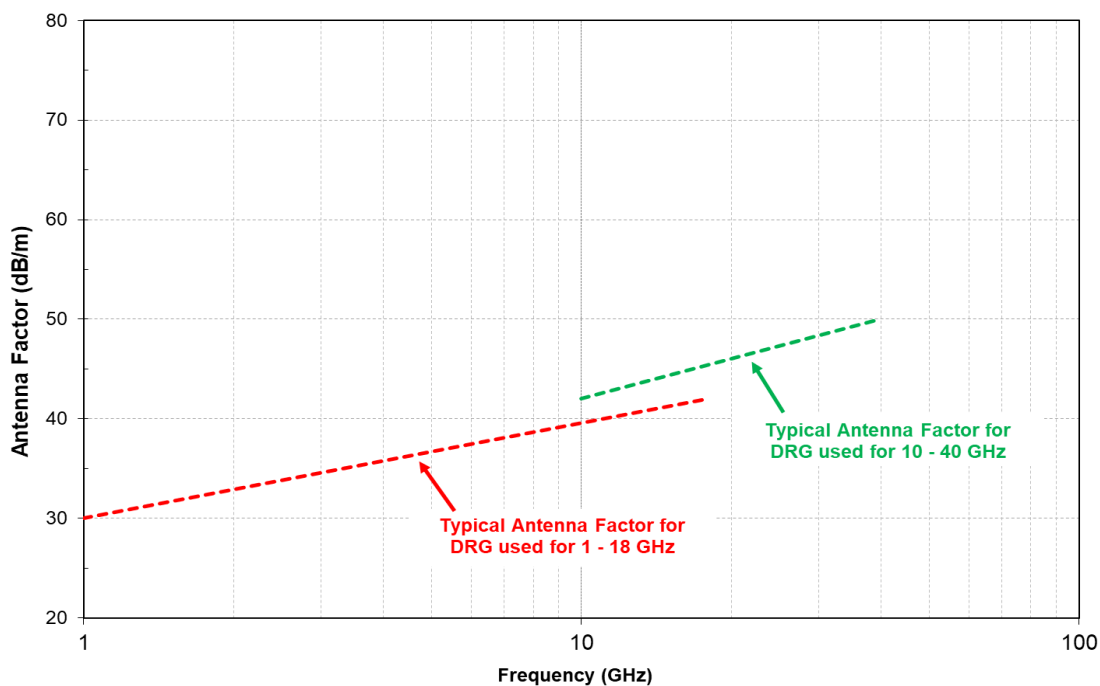

**Figure 2.5-86. Typical Antenna Factors for Measurement Antennas**

Check the GSFC Technical Standards Program website at <http://standards.gsfc.nasa.gov> or contact the Executive Secretary for the GSFC Technical Standards Program to verify that this is the correct version prior to use.

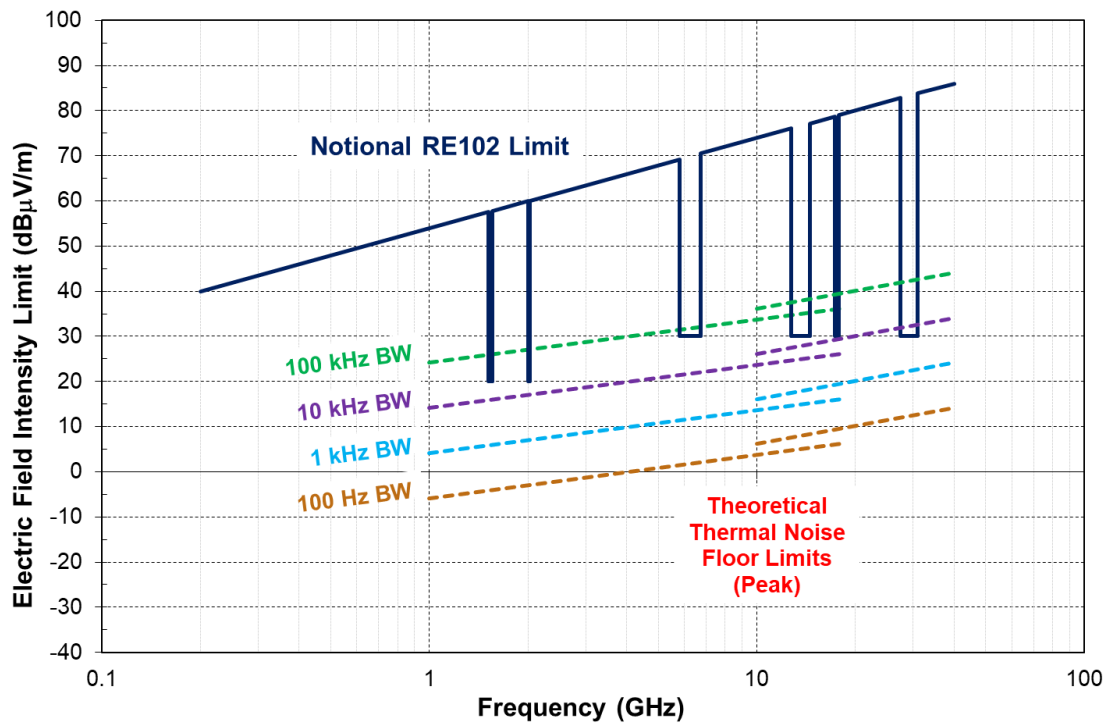

**Figure 2.5-87. Theoretical Floor Limits for Measurement System Using Peak Thermal Power**

As an example, in the S-band notch at 2000 – 2020 MHz, the minimum noise floor using the prescribed 10 kHz bandwidth is not quite low enough to meet the 6 dB below ambient requirement. The available options for reducing the noise floor are 1) use of a higher gain measurement antenna, and/or 2) use average detection instead of peak detection (recall that the noise floor for average detection is 11 dB lower than that for peak detection). This latter option is only available if continuous wave (CW) spurs are the only signals of interest.

If a higher gain antenna is employed, it must meet at least one of the following criteria:

- 1) the measured gain is calibrated at one meter per SAE ARP-958, and/or
- 2) the maximum aperture of the antenna “D” obeys the requirement that  $2D^2/\lambda$  is less than or equal to one meter

The latter stipulation is necessary because it is quite common in this type of situation to use standard gain horns or horn-fed dishes with quite high gains that are only specified in the far field, and stipulation (2) guarantees that the far field manufacturer-cited gain can be used to compute a one-meter antenna factor. If the antenna’s far field is greater than one meter, then it must either be calibrated at one meter per SAE ARP-958, or it may not be used.

It is not appropriate to arbitrarily reduce the bandwidth in order to reduce the noise floor. If the radio that is being protected implements a 10 kHz bandwidth, the measurement should be performed with a 10 kHz bandwidth. Reducing the measurement bandwidth below that of the platform receiver protected by the notch in order to reduce the noise floor will not provide an accurate measurement of the receiver’s response to signals with wider than the measurement bandwidth, and it will defeat the purpose of the test.

For the Ka-band notch at 27500 – 31000 MHz, the 1 kHz measurement bandwidth places the noise floor well below that required to make the measurement. However, the implications for sweep time must be considered. This notch has a width of 3500 MHz. The 1 kHz measurement bandwidth corresponds to 250 Hz between frequency steps in the sweep, or a total of 14,000,000 frequency steps. In the traditional frequency swept method, MIL-STD-461G specifies a dwell time of 0.015 second per frequency step, giving a total sweep time of 210,000 seconds = 58 hours. It must be noted that it applies to each polarization at each antenna position. With multiple antenna positions, and two polarizations at each position, this could easily add up to several weeks of testing on a single notch. Clearly this is not a very efficient approach.

If the actual frequency span of the Ka-band receiver used on the platform is known to be much narrower, the span of the notch should be narrowed accordingly in order to make most efficient use of test time. However, in many cases, radiated testing must be performed prior to final definition of the specific frequency ranges of receivers on the platform. In other cases, the test article is one unit in a large production lot that is intended to be used on a large number of platforms. In such cases, it is necessary to test over the full range of the notch.

A real-time FFT-based receiver/spectrum analyzer would significantly reduce the time for this sweep. On such units, the real-time measurement window ranges from 7 MHz for older units to 80 MHz on the latest units (as of this writing), and a dwell time of 1 second is typically used for each window. Continuing with the Ka-band notch example above, a machine with a 7 MHz real time window can cover the notch in  $3500 \text{ MHz} / (7 \text{ MHz/second}) = 500$  seconds, or just over 8 minutes. A machine with an 80 MHz window would cover the Ka-band notch in  $3500 \text{ MHz} / (80 \text{ MHz/second}) = 44$  seconds. This example clearly illustrates that real-time FFT-based receivers/spectrum analyzers can reduce the time required for these types of measurements from several weeks down to a few hours, Thus, making significantly more efficient use of test time. In addition, the FFT-based units are better suited to detect transient type signals than traditional receivers.

Additional attention must be paid to the characteristics of the sources of potential emissions. Figure 2.5-88 shows an example of a clock signal with a typical jitter specification of 50 parts per million (ppm) on its fundamental frequency. This 50 ppm specification will apply at all harmonics, which at 2 GHz equates to +/- 100 kHz. If the platform receiver uses a bandwidth of less than 100 kHz (e.g. 10 kHz), it may not capture all of the energy from this harmonic. However, if a measurement bandwidth is used that simulates that of the platform receiver, the measured response will be comparable to that of the platform receiver. If the measurement bandwidth is arbitrarily reduced even lower in order to reduce the noise floor, the measurement receiver will not capture all of the energy that may be captured by the platform receiver, and it may miss it altogether. The worst-case result is that it may give a false indication that the requirement has been met while masking a potential problem.

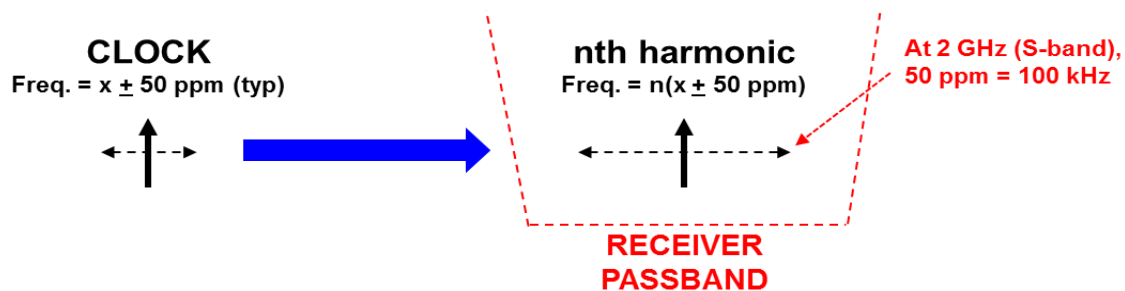

**Figure 2.5-88. Measurement Bandwidth and Clock Jitter**

Check the GSFC Technical Standards Program website at <http://standards.gsfc.nasa.gov> or contact the Executive Secretary for the GSFC Technical Standards Program to verify that this is the correct version prior to use.

### 2.5.3.3.7.5 Crest Factor for Thermal Noise

As discussed in the previous sections, the noise floor of a measurement device is generally expressed as a root mean square (rms) quantity in terms of its Displayed Average Noise Level (DANL).

However, MIL-STD-461G states in section 4.3.10.1, "A peak detector shall be used for all frequency-domain emissions and susceptibility measurements."

For any waveform, the ratio of the peak value to the rms value is defined as the Crest Factor (CF):

$$CF = \frac{V_{peak}}{V_{rms}}$$

For a simple sinusoid,  $CF = \sqrt{2} \approx 1.414$ .

Thermal voltage noise follows a Gaussian (normal) probability distribution, where the probability density  $f(x)$  for any given value of  $x$  is given by:

$$f(x) = \frac{1}{\sigma\sqrt{2\pi}} e^{-\frac{(x-\mu)^2}{2\sigma^2}}$$

where:

$\mu = \text{mean}$

$\sigma = \text{standard deviation unit}$

$x = \text{instantaneous noise voltage } V_N, \text{ normalized to } (V_N)_{rms} (V_N / (V_N)_{rms})$

This function is plotted in Figure 2.5-89. As shown in the figure, the probability density for values of  $|x| > 3.5$  is less than 0.001, which means that these values occur less than 0.1% of the time. This means that 99.9% of the time,  $|x| \leq 3.5$ . Thus, for all practical purposes, the peak value of  $x$  can be taken to be 3.5, which means that the peak value of  $|V_N|$  can be taken to be 3.5 times the rms value.

Converting the numeric value of 3.5 to dB gives:

$$20 \log_{10}(3.5) \approx 11 \text{ dB}$$

...which is the Crest Factor for thermal noise.

When using peak detection for measurements as specified by MIL-STD-461G, this value must be added to the DANL level specified for a given measurement device in order to get the true noise floor of the system.

Practical applications of the Crest Factor are discussed in the previous section.

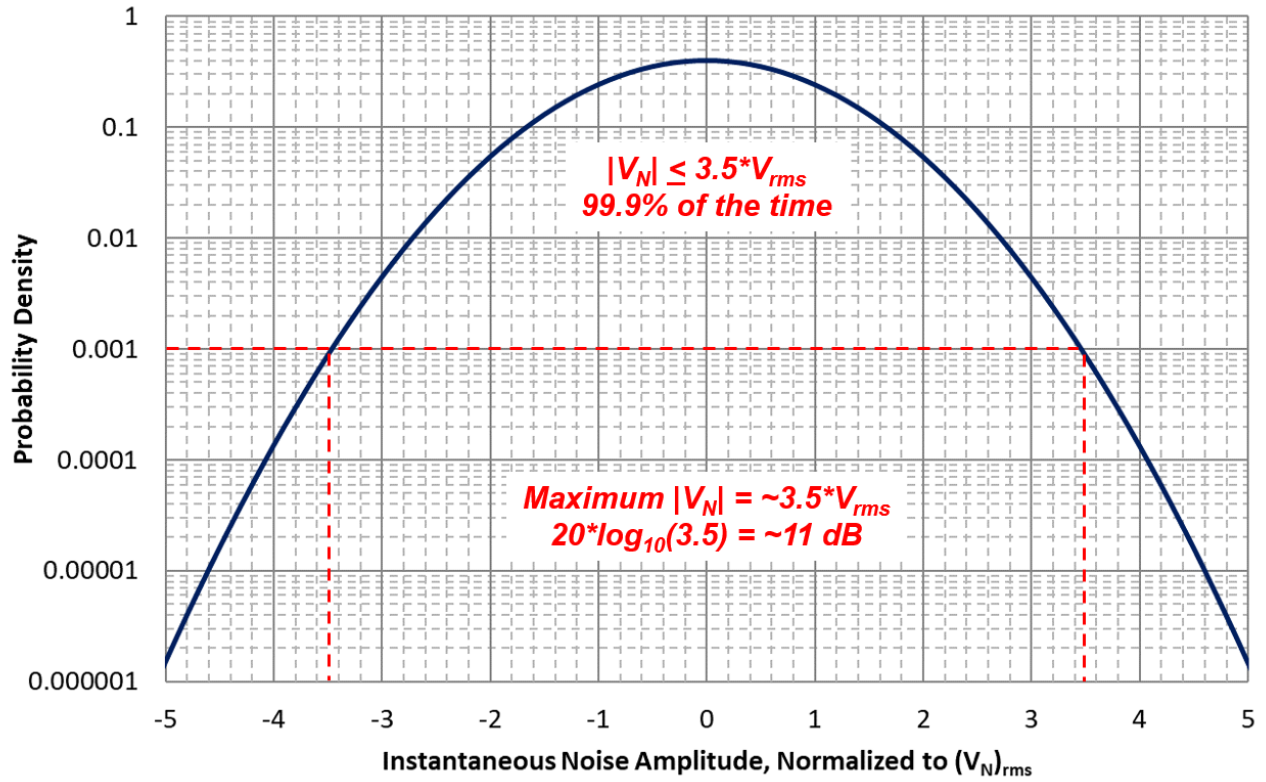

Figure 2.5-89. Probability Density of Thermal Voltage Noise

### 2.5.3.3.8 Radiated Susceptibility, Electric Field

#### 2.5.3.3.8.1 Antennas

The MIL-STD-461G RS103 test procedure does not specify any particular antennas for the standard test method. Although MIL-STD-461G discourages the use of conical log spiral antennas, they offer some advantages in certain applications as discussed below.

The double ridge horn has a constant aperture. This means the gain increases with frequency, which translates to a decreased field-of-view as frequency increases. The log-spiral and log periodic antennas have a lower and constant gain as a function of frequency, which translates into a wider and more constant field of view. For these reasons, the log-spiral and log periodic antennas are better suited to illuminate a given test setup using fewer antenna positions, Thus, reducing total test time. This can be a particularly significant advantage when performing a radiated emissions test on a larger test article such as an integrated instrument, payload, or spacecraft, when costs for test time are significantly higher due to “marching army” costs.

A few notes regarding log-spiral antennas:

- Log-spiral antennas are circularly polarized, which means that each of the horizontal and vertical (linear) components of an applied field are 3 dB below the level for the proper circular polarization. In order to produce the correct levels for the horizontal and vertical components, the applied power level at the antenna input must be 3 dB higher than that required to produce the desired level for a circularly polarized wave.
- The wide field-of-view (low gain) and circular polarization enable most susceptibility tests to be completed using only one position and one polarization.
- The log-spiral antenna only works up to 10 GHz; a different antenna must be used for radiated susceptibility testing above 10 GHz.
- The log-spiral antenna may not have sufficient power capability to achieve field levels higher than 20 V/m, particularly those simulating launch site transmitters. In such cases, an antenna with a higher power capability must be used.

#### 2.5.3.3.8.2 Antenna Positions and “Spot Sizes”

MIL-STD-461G specifies the following for RS103 antenna positions:

- For testing from 200 MHz up to 1 GHz, place the antenna in a sufficient number of positions such that the entire area of each EUT enclosure and the first 35 cm of cables and leads interfacing with the EUT enclosure are within the 3 dB beamwidth of the antenna.
- For testing at 1 GHz and above, place the antenna in a sufficient number of positions such that the entire area of each EUT enclosure and the first 7 cm of cables and leads interfacing with the EUT enclosure are within the 3 dB beamwidth of the antenna.

From the above, it is clear that susceptibilities of the interconnect cables are being evaluated along with the susceptibility of the EUT enclosure itself. ALL CABLES CONNECTING TO THE EUT ARE CONSIDERED PART OF THE TEST ARTICLE.

In order to optimize the number of antenna positions for a given test configuration, it is necessary to determine the area of the EUT that is illuminated by the antenna at a given location. This illuminated area is commonly called the “spot size.”

Spot sizes for RS103 configurations may be calculated in the same way as illustrated for RE102 in section 2.5.3.3.7.5.

While RE102 measurements are specified with the antenna at a distance of 1 meter from the EUT, RS103 poses no such restriction. The RS103 section in the Application Guide of MIL-STD-461 revisions F and later provides the following guidance:

“This version of MIL-STD-461 allows larger distances than 1 meter between the transmit antenna and the EUT boundary. This approach is actually preferable, where amplifier power is available to obtain the required field, since more of the EUT is illuminated at one antenna position.”

As discussed in section 2.5.3.3.7.5, spot size diameter scales directly with the distance  $r$  from the antenna to the EUT. Thus, moving the test antenna to  $r = 2$  meters will double the spot diameter. This also means that the power required to deliver the same electric field will quadruple. The relationship between transmitted power and electric field are discussed in section 2.5.3.3.8.4.

This approach offers a tremendous advantage in selecting an optimal number of antenna positions in order to provide sufficient coverage of the EUT and interconnect cables while making most efficient use of test time. Because RS103 tends to be the most time-consuming test in any campaign, optimizing antenna positions is a key consideration.

### 2.5.3.3.8.3 Field Probe Placement

If the real-time monitoring test method is used, guidelines for field probe placement are summarized below, using MIL-STD-461G sections 5.20.3.3.d.(1) and 5.20.3.3.e.(b) as points of departure:

- 1) General
  - a. Position at same distance from transmit antenna as EUT
  - b. Do not place directly at corners or edges of EUT components
- 2) Below 1 GHz
  - a. Vertical: Minimum of 30 cm above the ground plane
  - b. Horizontal: Within 35 cm of EUT
- 3) Above 1 GHz
  - a. Vertical: Place at height corresponding to the area of the EUT being illuminated
  - b. Horizontal: Within 3 dB beamwidth of transmit antenna
  - c. 3 dB beamwidth must be calculated from antenna characteristics and distance between antenna and EUT (1 m default per MIL-STD-461G RS103)
  - d. Place one edge of EUT as close as possible to edge of beam to maximize exposure to cables and to maximize available space for probe
  - e. Available space adjacent to EUT depends on size of EUT
  - f. If a larger beam is needed, the transmit antenna may be moved further away from the EUT. The necessary power must be calculated to generate the desired electric field at the desired distance (discussed in next section), and a suitable amplifier to provide that power must be selected for the test.

### 2.5.3.3.8.4 Transmitted Power vs. Radiated Electric Field

A useful and important relationship exists between transmitted power and radiated electric field.

Power density  $P_d$  of an electromagnetic wave is related to the electric field intensity  $E$  as follows:

$$P_d = \frac{E^2}{\eta}$$

where  $\eta$  is the wave impedance. For a plane electromagnetic wave travelling in air or vacuum,  $\eta$  is approximately equal to  $120\pi \Omega$  ( $\sim 377 \Omega$ ). This plane wave assumption is sufficient for most situations. Thus,

$$P_d = \frac{E^2}{120\pi}$$

For an isotropic source of electromagnetic energy, the power density at a distance  $r$  from the source is simply the total transmitted power  $P_t$  divided by the surface area of a sphere of radius  $r$ :

$$(P_d)_{isotropic} = \frac{P_t}{4\pi r^2}$$

For a real transmitting source, i.e. an antenna, the gain  $G$  is defined as the ratio of the power density in a given direction to the power density of an ideal isotropic source transmitting the same amount of power. The value of  $G$  (generally as a function of frequency) is provided in the datasheet for any candidate test antenna.

By definition, the power density at a distance  $r$  from a real transmitting source is:

$$P_d = \frac{P_t G}{4\pi r^2}$$

Setting the two expressions for  $P_d$  equal to each other and solving for  $P_t$  gives:

$$P_t = \frac{E^2 r^2}{30G}$$

Solving for  $E$  gives:

$$E = \frac{\sqrt{30P_t G}}{r}$$

The previous two equations are extremely useful tools for defining and evaluating a radiated susceptibility test configuration. The first calculates the amount of power required to establish a given electric field at a given distance from the transmit antenna. The second calculates the electric field that may be established at a given distance from the transmit antenna for a given amount of available power.

Although these equations do not consider factors as room reflections and cable losses, they provide a useful starting point for selecting an appropriate amplifier for a given test configuration.

For example, in order to establish a field of 20 V/m at 1 meter with an antenna with  $G = 6$ , the amount of power required is 2.2 Watts. An amplifier should be selected that can provide the necessary power with sufficient headroom, but not so much headroom that provides a risk of overtest. In this case, a 10-Watt amplifier would be a good selection.

If only a 100-Watt amplifier is available, then the maximum field level that could be applied is 134 V/m, which is clearly much higher than the 20 V/m requirement. In the event that the full level is applied (i.e. if software safeguards are insufficient to prevent it), it would be a significant overtest with an increased risk of damage. Thus, if the 100-Watt amplifier is the only one available, it is recommended to put a 10 dB attenuator (with appropriate power rating) on its output in order to limit the available power to 10 Watts. Another option is to connect the amplifier output to a directional coupler, and connect the coupled port to the antenna input.

As discussed in section 2.5.3.3.8.2, the RS103 test method does not specify that the antenna must be placed at  $r = 1$  meter from the EUT. The test antenna may be placed further from the EUT in order to produce a larger spot size as long as sufficient amplifier power is available and the test antenna has sufficient power capacity. As shown in the equations above, transmitted power scales with  $r^2$ . Thus, moving the test antenna back to a distance of 2 meters will quadruple the power required to produce a given electric field at the EUT. The equations in this section give the test engineer the necessary tools to determine if that is a worthy trade-off.

Additional discussion and examples are provided in the GEVS application note entitled, "Transmitted Power vs. Radiated Electric Field," available on the "GEVS Application Notes" page of the GSFC EMC Working Group SPACES site:

<https://spaces.gsfc.nasa.gov/display/EMCWG/GEVS+Application+Notes>

#### 2.5.3.3.8.5 RS "Survive Without Damage" Launch Site Limits

GSFC projects typically apply two sets of limits for radiated susceptibility (RS), one set for on-orbit operations and a second set for launch.

For equipment that must be powered on and operational at launch, the equipment must of course operate when exposed to these levels. As such, these limits should be verified by test.

For equipment that is not powered on at launch, the equipment is only required to survive without damage after exposure to the launch levels. "Survive-without-damage" requirements cannot be verified by test. Such tests are inherently inconclusive; they merely verify that the equipment under test (EUT) shows no obvious damage immediately after being subjected to the test environment. They provide no verification that the EUT was not stressed by the environment. Verification of "survive-without-damage" requirements must inherently be performed by analysis.

The mechanism for interference and/or damage from an incident electric field is that the incident field will induce a coupled potential and current onto some element of the EUT, e.g. cable, connector, improperly sealed seam, etc. The coupling efficiency of any slot, cable or electrical circuit increases with increasing frequency until the cable is electrically long. In general, this means that cables are the primary coupling path until very high frequencies, e.g. several hundreds of MHz. In the remainder of this application note, the cable will be treated as a bulk circuit element, and all coupling is assumed to be common mode unless otherwise stated.

When a cable's separation from the ground plane is electrically short, i.e. less than  $\lambda/10$ , the cable acts as a wire-above-ground transmission line, the parameters of which are discussed in section 2.5.3.3.9. For frequencies at which the cable-to-ground separation is electrically long, i.e. greater than  $\lambda/10$ , the cable acts as a dipole antenna. The default cable-to-ground separation specified by MIL-STD-461 is 5 cm, which equals  $\lambda/10$  at 600 MHz. Therefore, 600 MHz is the frequency break point between the two analysis methods discussed herein.

Field-to-wire coupling is discussed in further in section 2.5.3.3.6.1.1.

The two analysis methods are presented in the following sections.

### 2.5.3.3.8.5.1 Transmission Line Method ( $f < 600$ MHz)

At frequencies for which the cable's separation from the ground plane is less than  $\lambda/10$ , the transmission line model is used. Using the default 5 cm separation, this corresponds to frequencies below 600 MHz. As shown in section 2.5.3.3.6.1.1, the worst-case coupled common mode potential  $V_{CM}$  increases with increasing frequency until the cable is electrically long, at which point it reaches an asymptote value given by:

$$V_{CM} = \pi h E$$

where  $h$  is the height of the cable above the ground plane. For  $h = 5$  cm, the relationship is approximately 150 mV per V/m. If the cable is unshielded, e.g. primary power, this potential will be directly imparted to each wire in the bundle.

A typical RS launch level is 20 V/m. This would produce a worst-case coupled potential of 3 V onto each wire in an unshielded bundle. In a cable that is designed to carry primary power with potentials of +28 Vdc or higher, a worst-case coupled potential of 3 V does not pose any risk of damage. There should not be any risk of damage on such cables for coupled potentials up to 28 V peak-to-peak = 10 Vrms, which corresponds to RS launch levels of up to 66 V/m.

For signal cables connected to circuits for which such potentials would pose a risk of damage, such cables must be shielded with the shield properly terminated on both ends. For shielded cables, an accurate estimate of worst-case coupled current may be obtained by applying the guidance below from the CS114 limits of MIL-STD-461 (post 1993), as shown in Figure 2.5-90. Further discussion of these CS114 limit curves and their relationship to the default RS103 limits is provided in section 2.5.3.3.6.

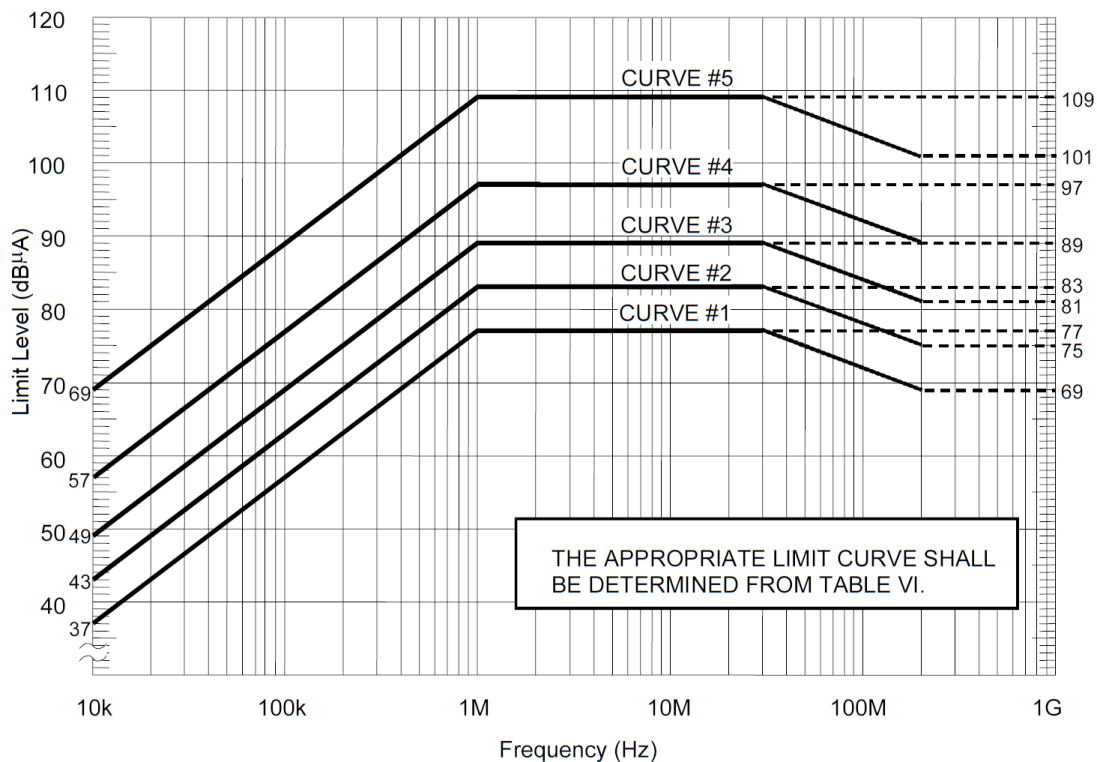

**Figure 2.5-90. MIL-STD-461G CS114 Calibration Limits**

Check the GSFC Technical Standards Program website at <http://standards.gsfc.nasa.gov> or contact the Executive Secretary for the GSFC Technical Standards Program to verify that this is the correct version prior to use.

The CS114 limit was specifically developed as a way of simulating currents on cables that would be induced by an incident radiated field, e.g. from a radiated susceptibility test. As such, each limit curve reproduced in Figure 1 corresponds to an RS103 limit.

The relationship between the CS114 and RS103 levels is provided in MIL-STD-461G section A.5.13:

“The basic relationship for the limit level in the resonance (flat) portion of the curve is 1.5 mA per V/m that is derived from worst-case measurements on aircraft. For example, 110 dB $\mu$ A corresponds to 200 V/m.”

This relationship follows naturally from the 150 mV per V/m relationship given above, because the CS114 test method pre-calibrates the injected signal into a calibration fixture with a total loop impedance of 100  $\Omega$ .

This gives the worst-case common mode current  $I_{CM}$  for a given incident electric field  $E$ :

$$I_{CM} = E \cdot (1.5 \text{ mA}/(\text{V}/\text{m}))$$

For shielded cables,  $I_{CM}$  is the current induced on the shield. The ultimate concern is the potential coupled to a signal carrying wire inside the cable. This will be determined by the total transfer impedance of the shield,  $Z_{tot}$ :

$$V_{wire} = I_{CM} \cdot Z_{tot}$$

The subject of transfer impedance is discussed in further detail in the GEVS application note entitled, “Shield Transfer Impedance – RG-58C/U Example.” This note is available on the “GEVS Application Notes” page of the GSFC EMC Working Group SPACES site:

<https://spaces.gsfc.nasa.gov/display/EMCWG/GEVS+Application+Notes>

Following the example discussed in that note for RG-58C/U, a value of 1  $\Omega$  is used for  $Z_t$  as a worst-case.

A typical RS launch level is 20 V/m. This would convert to an  $I_{CM}$  of 30 mA and a  $V_{wire}$  of 30 mV.

Using the same analysis, an RS launch level of 66 V/m would convert to an  $I_{CM}$  of 100 mA and a  $V_{wire}$  of 100 mV.

Except in cases of cables connected to extremely sensitive circuitry, these are significantly lower than any levels that should pose any risk of damage.

### 2.5.3.3.8.5.2 Dipole Method ( $f > 600$ MHz)

At frequencies for which the cable's separation from the ground plane is greater than  $\lambda/10$ , it will behave as a dipole antenna. Using the default 5 cm separation, this corresponds to frequencies above 600 MHz. In general, launch levels are applied at frequencies above 1 GHz, which means that the dipole model should suffice in most cases.

The worst-case coupling will result when it behaves as a tuned half-wave dipole antenna. For any antenna, intentional or unintentional, the parameter for converting an incident electric field intensity to a potential at the antenna's output terminals is the antenna's effective height,  $h_e$ . The open-circuit effective height of a tuned half-wave dipole is given by:

$$h_e = \frac{\lambda}{\pi} = \frac{c}{\pi f}$$

where:

- $\lambda$  = wavelength (meters)
- $c$  = speed of light =  $3 \times 10^8$  m/s
- $f$  = frequency (Hz)

The worst-case open-circuit common mode potential coupled onto a cable,  $V_{CM}$ , is given by the applied electric field  $E$  multiplied by  $h_e$ :

$$V_{CM} = E \cdot h_e$$

The output impedance of a half-wave dipole antenna is approximately  $73 \Omega$ . The worst-case common mode current  $I_{CM}$  will occur when the antenna (i.e. the victim cable in this case) is connected to a dead short, which will be the case for a shielded cable whose shield is terminated to chassis or structure at both ends.

Thus, the maximum value of  $I_{CM}$  will occur when  $V_{CM}$  is dropped completely across this output impedance:

$$I_{CM} = \frac{V_{CM}}{73 \Omega}$$

For shielded cables,  $I_{CM}$  can be taken to the current induced on the shield. Again, the ultimate concern is the worst-case potential  $V_{wire}$  coupled to a signal carrying wire inside the cable:

$$V_{wire} = I_{CM} \cdot Z_{tot}$$

Again using RG-58C/U as an example, a value of  $1 \Omega$  may be assumed for  $Z_{tot}$  as a worst-case.

The following example illustrates this analysis approach for unshielded as well as shielded cables.

A typical RS launch limit is a level of 20 V/m applied over the frequency range of 1 – 6 GHz. In general, outside this frequency range, the launch levels are lower than the on-orbit levels.

The largest  $h_e$  in this frequency range is 0.095 m, corresponding to  $f = 1$  GHz. The worst-case value of  $V_{CM}$  resulting from the measured electric field of 20 V/m is:

$$V_{CM} = E \cdot h_e = (20 \text{ V/m}) \cdot (0.095 \text{ m}) = 1.9 \text{ V}$$

The worst-case value of  $I_{CM}$  is:

$$I_{CM} = \frac{1.9 V}{73 \Omega} = 26 mA$$

In an unshielded cable, e.g. primary power, this potential and current will be directly coupled to each wire in the bundle. In a cable that is designed to carry primary power with potentials of +28 Vdc or higher and currents of several amperes, these levels do not pose any risk of damage.

Note that  $h_e$ , is inversely proportional to frequency, which in turn means that  $V_{CM}$  and  $I_{CM}$  are inversely proportional to frequency. Therefore, at 6 GHz,  $V_{CM}$  and  $I_{CM}$  will be a factor of 6 lower than the values calculated above at 1 GHz.

As stated above, there should not be any risk of damage on unshielded primary power cables for coupled potentials up to 28 V peak-to-peak = 10 Vrms. This corresponds to an RS level of approximately 100 V/m at 1 GHz and increasing linearly with frequency.

For signal cables connected to circuits for which such potentials would pose a risk of damage, such cables must be shielded with the shield properly terminated on both ends.

For an RS launch level of 20 V/m applied from 1 – 6 GHz, the worst-case coupled potential to a signal carrying wire inside the cable is given by:

$$V_{wire} = I_{CM} \cdot Z_{tot} = (26 mA)(1 \Omega) = 26 mV$$

Using the same analysis, an RS launch level of 100 V/m would produce a worst-case  $V_{wire}$  of 130 mV at 1 GHz. The RS level that would couple this same level will increase linearly with frequency. Again, except in cases of cables connected to extremely sensitive circuitry, these are significantly lower than any levels that should pose any risk of damage.

Note that because coupling efficiency decreases with increasing frequency, the maximum tolerable electric field increases with increasing frequency. In this example, the equipment can withstand a level of 100 V/m at 1 GHz and a level of 1000 V/m at 10 GHz.

When possible, the transfer impedance of representative cables should be characterized following the example outlined in section 2.5.3.8.8.1.3, and those values must be used in the calculations above. The values used herein are used to illustrate the analysis approach and are intended as a worst case, but it is possible that the actual values in a given application may present an even worse case.

### 2.5.3.3.9 Wire-Above-Ground Transmission Line Parameters

A wire or cable above a ground plane will behave as a wire-above-ground transmission line, the key parameters of which are described below.

The inductance and capacitance per unit length of a wire-above-ground transmission line in free space are as follows:

$$L = \frac{\mu_0}{2\pi} \ln \left[ \frac{h}{a} + \sqrt{\left(\frac{h}{a}\right)^2 - 1} \right]$$

$$C = \frac{2\pi\epsilon_0}{\ln \left[ \frac{h}{a} + \sqrt{\left(\frac{h}{a}\right)^2 - 1} \right]}$$

where:

$\mu_0$  = permeability of free space =  $4\pi \times 10^{-7}$  H/m

$\epsilon_0$  = permittivity of free space =  $1/(36\pi) \times 10^{-9}$  F/m

$h$  = height of wire (cable) above ground plane

$a$  = wire (cable) radius

The characteristic impedance  $Z_0$  is:

$$Z_0 = \sqrt{\frac{L}{C}} = \frac{1}{2\pi} \sqrt{\frac{\mu_0}{\epsilon_0}} \ln \left[ \frac{h}{a} + \sqrt{\left(\frac{h}{a}\right)^2 - 1} \right]$$

But  $\sqrt{(\mu_0/\epsilon_0)}$  is the characteristic impedance of free space, which equals  $120\pi \approx 377 \Omega$ . Thus:

$$Z_0 = 60 \cdot \ln \left[ \frac{h}{a} + \sqrt{\left(\frac{h}{a}\right)^2 - 1} \right]$$

These relationships are plotted in Figure 2.5-91, Figure 2.5-92, and Figure 2.5-93. For the examples used in this note,  $h/a = 100$  ( $h = 5$  cm and  $a = 0.5$  mm), which gives the following typical values:

$$L \approx 1 \mu\text{H/m}$$

$$C \approx 10 \text{ pF/m}$$

$$Z_0 \approx 300 \Omega$$

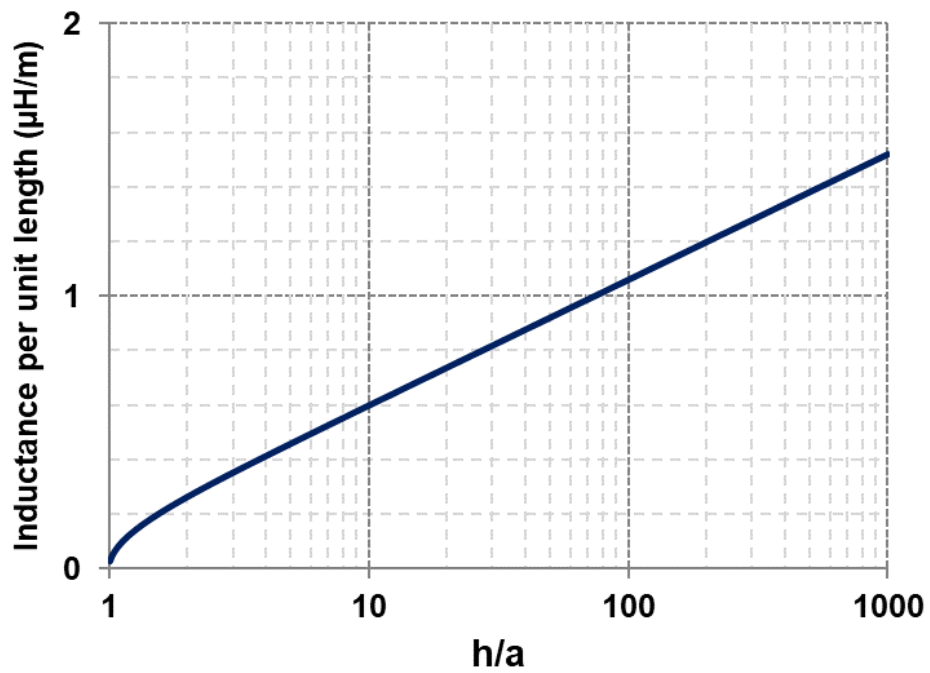

Figure 2.5-91. Inductance Per Unit Length, Wire Above Ground

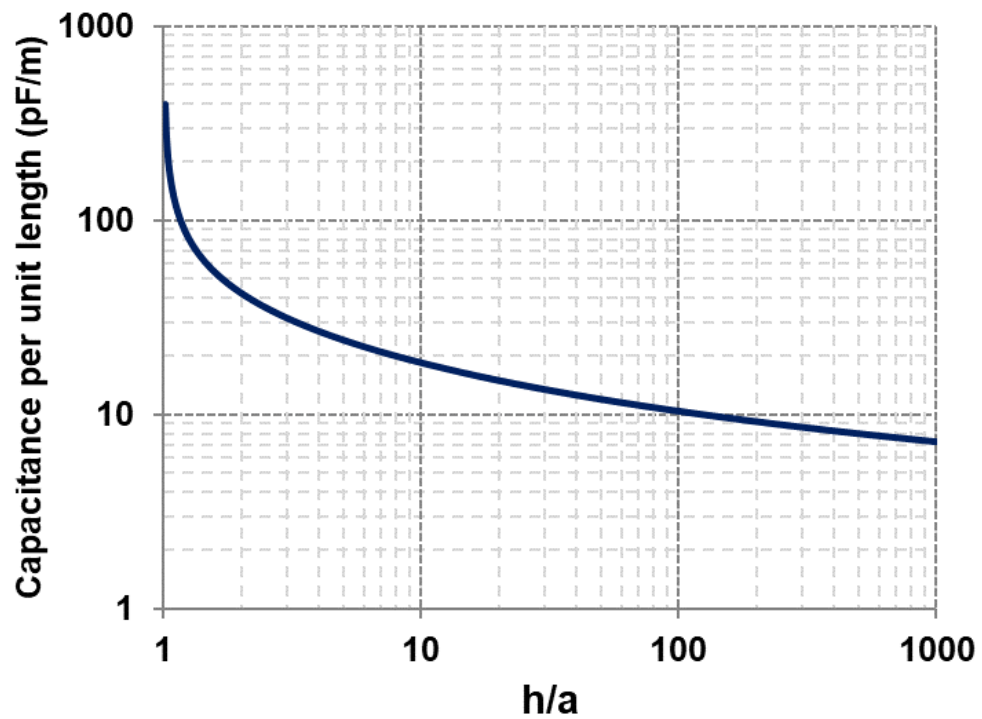

Figure 2.5-92. Capacitance Per Unit Length, Wire Above Ground

Check the GSFC Technical Standards Program website at <http://standards.gsfc.nasa.gov> or contact the Executive Secretary for the GSFC Technical Standards Program to verify that this is the correct version prior to use.

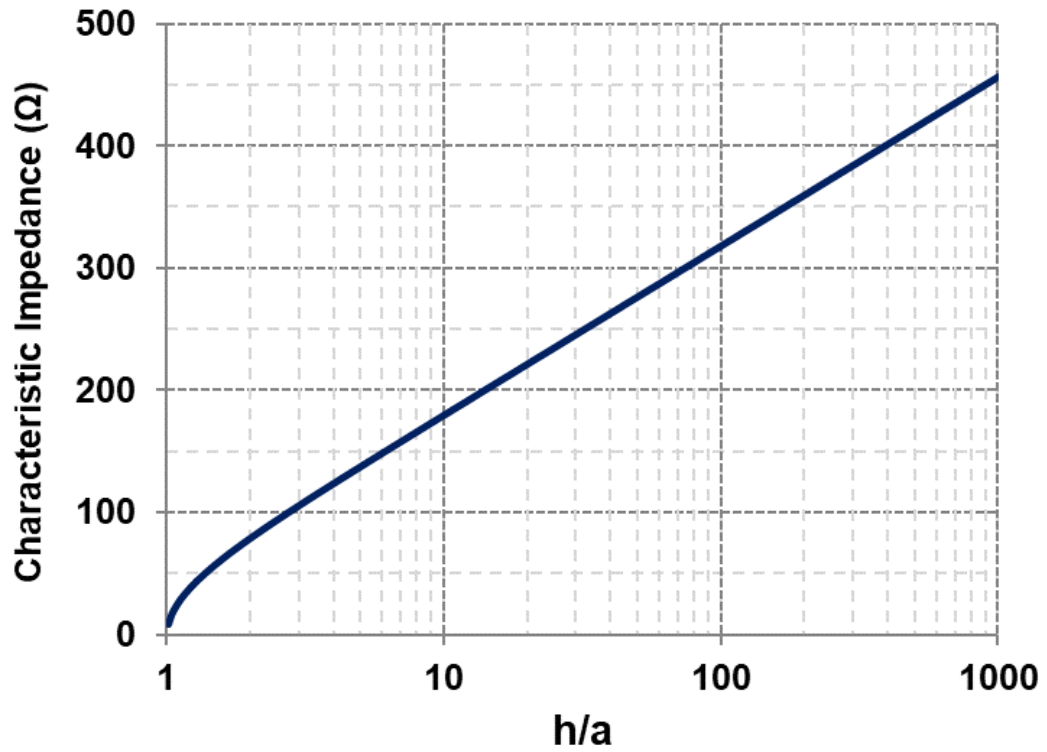

Figure 2.5-93. Characteristic Impedance, Wire Above Ground

2.5.3.4 Abbreviations, Acronyms, Constants, and Relations

<i>Abbreviations/acronyms:</i>	
<i>AC</i>	<i>Alternating Current</i>
<i>BCE</i>	<i>Bulk Cable Emission</i>
<i>BCI</i>	<i>Bulk Cable Injection</i>
<i>CE</i>	<i>Conducted Emissions</i>
<i>CM</i>	<i>Common Mode</i>
<i>CS</i>	<i>Conducted Susceptibility</i>
<i>CW</i>	<i>Continuous Wave</i>
<i>DANL</i>	<i>Displayed Average Noise Level</i>
<i>dB</i>	<i>Decibels</i>
<i>DC</i>	<i>Direct Current</i>
<i>DM</i>	<i>Differential Mode</i>
<i>EGSE</i>	<i>Electrical Ground Support Equipment</i>
<i>EMC</i>	<i>Electromagnetic Compatibility</i>
<i>EMI</i>	<i>Electromagnetic Interference</i>
<i>EMP</i>	<i>Electromagnetic Pulse</i>
<i>ESD</i>	<i>Electrostatic Discharge</i>
<i>EUT</i>	<i>Equipment Under Test</i>
<i>FFT</i>	<i>Fast Fourier Transform</i>
<i>LISN</i>	<i>Line Impedance Stabilization Network OR Line Impedance Simulation Network</i>
<i>RE</i>	<i>Radiated Emissions</i>
<i>RS</i>	<i>Radiated Susceptibility</i>
<i>VSWR</i>	<i>Voltage Standing Wave Ratio</i>

Check the GSFC Technical Standards Program website at <http://standards.gsfc.nasa.gov> or contact the Executive Secretary for the GSFC Technical Standards Program to verify that this is the correct version prior to use.

<i>Constants</i>	
$\mu_0$	<i>permeability of free space</i> = $4\pi \times 10^{-7} \text{ H/m} \approx 1.3 \text{ } \mu\text{H/m}$
$\epsilon_0$	<i>permittivity of free space</i> = $1/36\pi \times 10^{-9} \text{ H/m} \approx 8.8 \text{ pF/m}$

<i>Relations</i>	
<i>Angular frequency</i>	$\omega = 2\pi f$
<i>Characteristic impedance of medium</i>	$\eta = \sqrt{\frac{\mu_r \mu_0}{\epsilon_r \epsilon_0}}$
<i>Characteristic impedance of air (<math>\mu_r = \epsilon_r = 1</math>)</i>	$\eta_0 = \sqrt{\frac{\mu_0}{\epsilon_0}} = 120\pi \text{ } \Omega \approx 377\Omega$
<i>Velocity of propagation in medium</i>	$v = \frac{1}{\sqrt{\mu_r \mu_0 \epsilon_r \epsilon_0}}$
<i>Velocity of propagation in air (<math>\mu_r = \epsilon_r = 1</math>)</i>	$c = \frac{1}{\sqrt{\mu_0 \epsilon_0}} = 3 \times 10^8 \text{ m/sec}$
<i>Wavelength:</i>	$\lambda = \frac{c}{f} = \frac{300}{f_{\text{MHz}}} = \frac{0.3}{f_{\text{GHz}}}$
<i>Wavenumber</i>	$\beta = \frac{\omega}{c} = \frac{2\pi}{\lambda}$

## SECTION 2.6

### THERMAL

## 2.6 THERMAL VERIFICATION TESTING – GENERAL

Based on the heritage protoflight qualification (“proto-qualification”) test verification approach used by the Goddard Space Flight Center in lieu of a traditional qualification-acceptance test program, these test guidelines are intended to demonstrate that the design, and manufacturing processes will produce hardware that meets the mission requirements, yet remain available for flight. These guidelines have been developed based on decades of successful NASA high reliability missions, and emphasize thermal stress workmanship screening, combined with performance testing at temperature extremes, for all levels of assembly. Modifications to these guidelines for higher risk tolerant missions using GSFC guidelines, have been assessed, and are documented herein, if applicable.

Thermal verification testing focuses on performance verification and workmanship screening at temperatures extended beyond the mission allowable temperature range. This testing is an integral part of an environmental test program for all ELV payloads and science instruments, and is applicable to all mission risk classifications. An appropriate set of environmental tests and analyses is designed to meet these fundamental objectives:

**Flight Hardware Performance Verification:** Verify hardware performs to specification requirements at all levels of assembly, in vacuum and at temperatures extended beyond those allowed during the mission lifetime, including any special tests needed. These extended temperatures also serve as Environmental Stress Screening (ESS) plateaus where thermally induced stresses identify latent defects in parts, materials, and workmanship using performance data recorded during testing.

**Thermal Performance Verification:** Verify thermal subsystem performance, i.e. – demonstrate that thermal subsystem design requirements are met, and that all hardware is maintained within the established mission thermal limits, in thermal vacuum testing while simulating planned mission phases/operational modes including survival/safe-hold, if applicable. This test provides data to correlate the thermal model(s) which will improve the accuracy of mission predictions.

Note that GEVS does not specify thermal design standards or requirements - those are provided in other Branch documentation - rather it documents the standards for verification of the thermal design requirements, through thermal testing. It is recommended that these thermal verification tests occur after successful mechanical testing at the unit, subsystem, and system levels. Successful completion of these thermal verification tests proves the flightworthiness of the hardware.

### 2.6.1 Definitions

#### Test Philosophy

**Protoflight:** Test margin is 10°C beyond the Allowable Flight Temperature (AFT) range. (AFT is defined as the specific temperature range where a unit can operate and meet performance requirements over the mission lifetime.) Multiple units on the same payload/system or on multiple systems launched at the same time, are all to be tested to protoflight levels. Protoflight testing is preferred for all GSFC hardware. Qualification/Acceptance testing, defined below, is an acceptable alternative to protoflight testing.

**Qualification:** Test margin is 15°C beyond the AFT range. The baseline qualification test approach consists of designing and testing *dedicated test hardware* to qualification levels to verify the design, demonstrate margin, and validate an acceptance test program allowing multiple builds and/or rework cycles. Only in this test approach can subsequent flight hardware be acceptance tested to

demonstrate functional and/or performance to specification. Due to the robustness of testing, qualification hardware is not available for flight.

Acceptance: Test margin is 5°C beyond the AFT range. This approach tests *flight hardware* at the lowest levels; traditionally following successful *qualification* testing that has demonstrated a robust design and validated the acceptance testing as providing sufficient workmanship screening. If approved, this type of testing should only be used after successful protoflight testing is completed through the payload/system level, and mission performance is shown to perform successfully. It should not be used on subsequent units on the same payload/system or on multiple systems launched at the same time (see protoflight).

#### Level of Assembly

Unit: A functional item that is viewed as a complete and separate entity for purposes of manufacturing, maintenance, or record keeping. Examples include individual electronics box, battery, thruster, and mechanism.

Subsystem: An assembly of functionally related units, consisting of two or more units and may include interconnection items, such as cables or tubing, and the supporting structure to which the units are mounted. For GSFC missions, besides the functional subsystems (power, GN&C, COM, propulsion, and thermal), science instruments and operational modules, such as robotic servicing/assembly modules, are also considered as subsystems.

System: An integrated assembly of subsystems and units capable of supporting an operational role in space. For GSFC missions, a system is typically a flight hardware payload of an ELV and is a vehicle (satellite) including science instruments that constitute its mission.

#### Margins:

Thermal Test Margin: Temperature margin that is added to the unit operational (AFT) range and intended to prove the design of the hardware is flight worthy by demonstrating performance at temperatures beyond where it is allowed to operate. This test temperature range is based on hardware performance at the largest range possible where specifications are met, and not on mission predictions from thermal analysis. Acknowledging that different types of flight hardware have very different ranges, these test ranges must be understood and specified early in the mission development (typically in Phase A) to derive the operating temperatures to be used to develop the thermal control subsystem. Note that test margin is not typically applied on *non-operational* temperatures since they are established based on the actual hardware limits and damage may occur if exceeded.

Cryogenic: Test temperature margins added to the unit operational (AFT) range for cryogenic hardware should prescribe the same approach as non-cryogenic hardware, but also consider whether it is achievable or detrimental to the hardware at these extreme cold temperatures (Section 2.6.3.2.1). Additional information on cryogenic test margins is contained in Section 2.7.3.4.

Thermal Design Margin: Temperature margin applied to thermal model predictions for *operational* equipment, at all phases of the mission, from pre-Phase A through launch and final mission predictions using the correlated thermal model. It is intended to account for the inherent uncertainty in parameters used in the analysis, such as dissipations/power, model granularity, interface conduction, ground simulation limitations, surface properties and geometry/nodalization, and numerous other factors that go into the thermal models. It also accounts for the lingering error between the correlated model temperature predictions and actual flight temperatures.

Check the GSFC Technical Standards Program website at <http://standards.gsfc.nasa.gov> or contact the Executive Secretary for the GSFC Technical Standards Program to verify that this is the correct version prior to use.

**Note: GEVS does not specify design margins; rather it prescribes methods to verify these margins are met during thermal verification testing.**

Cryogenic: The GSFC Cryogenics Branch (Code 552) has updated the prescribed design (uncertainty) margins (Section 2.6.4.1) to be used on all cryogenic projects throughout the development cycle. Additional information is contained in Section 2.7.3.4 and Table 2.7-2.

STOP: a multidiscipline **S**tructural/**T**hermal/**O**ptical **P**erformance analysis typically performed for distortion sensitive parts of the satellite, such as optics and/or optical paths, optical bench, instrument mounting and pointing structure, where the thermal model generates appropriate temperatures that are mapped onto a structural model to determine displacements/motions of the various elements which are then applied to the optical model. Temperature variant properties should be used in these analyses to ensure stresses and alignments are acceptable for the given transition rate.

### Temperature Ranges

The allowable operational and non-operational ranges are *based on* design limits of the unit, and should be as robust as possible. They are *not derived from* temperature predictions for any mission.

Operational: the specific temperature range where a unit can operate and meet performance requirements over the mission lifetime. This is typically referred to as Allowable Flight Temperature (AFT).

Non-operational: the specific temperature range that a unit can withstand exposure to, and once returned to its protoflight limits, can subsequently meet operational performance requirements. This range is based on hardware survival limits, and is typically much broader than the operational range. Hot turn-on limits should not exceed the protoflight limit, while the cold turn on limits may be the same as the non-operational limit, allowing internal heat dissipation to warm the unit to the cold protoflight limit and subsequently meet operational performance requirements.

### Temperature Regimes

Non-cryogenic: >120K (-153°C)

Cryogenic: <120K (-153°C)

### Thermal Control Type:

Passive: based on material selection to tailor conduction, natural convection (if applicable), and radiation properties, including MLI, coatings, fillers, gaskets/washers/doublers/straps, constant conductance heat pipes (CCHP).

Active: uses separate device(s) to control heat transfer, such as heaters, louvers, pumped fluid loops (single- and two-phase), variable conductance heat pipes (VCHP), loop heat pipes (LHP), Capillary Pumped Loops (CPL) technology, Thermo-Electric Coolers, mechanical louvers, forced convection (if applicable). Typically requires temperature based feedback heater control.

### Types of Testing:

Thermal Vacuum Cycling: refers to verification testing of flight hardware over the test temperature range (AFT + test margin) while operating under vacuum, and repeated over the prescribed number of cycles and durations.

Thermal Balance Testing: refers to specific phases of thermal vacuum testing that are designed to demonstrate thermal subsystem performance in a stable, accurate energy balance at simulated worst hot

Check the GSFC Technical Standards Program website at <http://standards.gsfc.nasa.gov> or contact the Executive Secretary for the GSFC Technical Standards Program to verify that this is the correct version prior to use.

and cold environments that are derived from the mission thermal analysis, while operating the test hardware in the appropriate mission configuration and providing temperature and power data to correlate thermal models.

Tolerances:

Pressure: no greater than:

<u>Pascal</u>	<u>Torr</u>	<u>Tol (%)</u>
> $1.3 \times 10^4$	> $1.0 \times 10^2$	+/- 5%
$1.3 \times 10^2$ to $1.3 \times 10^4$	$1.0 \times 10^0$ to $1.0 \times 10^2$	+/- 10%
$1.3 \times 10^1$ to $1.3 \times 10^2$	$1.0 \times 10^{-1}$ to $1.0 \times 10^0$	+/- 25%
< $1.3 \times 10^1$	< $1.0 \times 10^{-1}$	+/- 80%

Temperature:  $\pm 2^\circ\text{C}$ .

## 2.6.2 General Requirements

Thermal verification testing references all testing at any level of assembly that is performed during simulated vacuum/pressure and temperature environments of the mission, with the fundamental purpose of demonstrating that the hardware meets all performance and workmanship requirements.

Thermal vacuum cycling is intended to (a) demonstrate performance of the flight hardware and (b) provide Environmental Stress Screening (ESS), over a temperature range extended just beyond that which the flight hardware is allowed to operate in over the mission lifetime. To fully test the hardware and achieve sufficient operating time, while inducing sufficient thermal stresses to identify latent workmanship defects before flight, testing is repeated over the specified number of cycles at each level of assembly.

Thermal balance testing is performed as part of subsystem (instrument) and system (space vehicle) thermal vacuum testing to verify the thermal subsystem design meets requirements. These test phases are designed to verify all aspects of the thermal hardware, including heater operation and control, radiator sizing, and critical heat transfer paths, by demonstrating thermal control requirements are met in the bounding simulated environments of the mission, while providing the temperature and power data necessary to correlate the thermal analytical model(s) that will be used to provide temperature predictions for mission usage. All payloads are to be tested at the worst case hot and cold thermal vacuum environments derived from those expected for their particular mission, to achieve the specific test margins.

This section establishes a baseline thermal environmental verification program at all levels of assembly to provide a high probability of success for meeting performance requirements over mission life. The following sections contain specifications applicable to each level of assembly. Additionally, the hardware must withstand, as necessary, the temperature and/or humidity conditions of transportation, storage, launch, flight, and crewed spaces.

### 2.6.2.1 Applicability

The test specifications in the following sections apply to all flight hardware for all GSFC missions, whether in-house or contracted, and for any mission risk classification. In-house projects must incorporate these specifications within their verification requirements documentation and ensure that the flight unit qualification complies with these specifications. For out-of-house projects, it is incumbent upon the project to incorporate these specifications within their contractual documents, so that the prime contractor has ultimate responsibility for ensuring that the hardware verification complies with these specifications. The contractor will also provide necessary and sufficient evidence to demonstrate compliance.

### 2.6.2.2 Spare Hardware

Spare hardware is typically procured concurrently with the flight hardware for a project and undergoes a test program in which the number of thermal cycles and test levels/durations are equivalent to the *total*

Check the GSFC Technical Standards Program website at <http://standards.gsfc.nasa.gov> or contact the Executive Secretary for the GSFC Technical Standards Program to verify that this is the correct version prior to use.

number of cycles to which other flight components (i.e., non-spare) are subjected at the component, subsystem, and payload levels of assembly, thus allowing them to be used at any point in the assembly. As a minimum, spare components are to be subjected to eight thermal cycles prior to integration onto the subsystem/instrument or system/satellite before system test, and twelve cycles if integrated after system test.

#### 2.6.2.2.1 Multiple Hardware

Historically, GSFC missions have been predominantly unique, singular flight systems, but the trend to missions with multiple flight systems continues to increase in recent years. Similar to “Spare Hardware” above, hardware for these missions is typically procured or manufactured concurrently and should follow GSFC’s protoflight test approach, receiving the same number of cycles and to the same temperature range, at the various levels of assembly. Similarly, thermal balance testing should be repeated on all multi-flight subsystems and systems, to verify performance and workmanship of the thermal subsystem.

#### 2.6.2.2.2 Reworked or Repaired Equipment

Retesting is required if a test discrepancy or test item failure occurs while performing any of the required testing steps, and root cause investigation requires any hardware disassembly, rework or repair. For repaired equipment, subsequent retesting must be sufficient to return the hardware to flight worthiness. The point in the integration flow at which the rework was necessary, the amount of rework, and the point at which it will be reinstalled on the flight system, all influence the required amount of retesting. Ideally, the total number of successful cycles completed following the rework, must meet the 12 cycle specification.

- For hardware that fails during unit level testing, following the necessary repairs/rework, repeat the entire unit level thermal vacuum testing.
- For hardware that fails during subsystem level testing:
  - o The repaired/reworked unit(s) repeat a minimum of 4 unit level cycles, prior to reinstallation into the subsystem, for subsequent completion of at least 2 subsystem cycles.
  - o If no subsequent subsystem cycles will be completed prior to installation into the system, then the repaired/reworked unit(s) repeat a minimum of 8 unit level cycles, prior to reinstallation into the subsystem.
- For hardware that fails during system level testing:
  - o Subsystem hardware:
    - If subsequent system testing remains: the subsystem unit is removed, repaired, and retested for a minimum of 6 cycles, prior to reinstallation into the subsystem/system, which then completes the remaining system level testing
    - If no system level testing is to be repeated: the subsystem is removed, repaired, and retested for a minimum of 6 cycles, prior to reinstallation into the system, which then completes the remaining system level testing
  - o System hardware:
    - If subsequent system testing remains: the unit is removed, repaired, and retested for a minimum of 6 cycles, prior to reinstallation into the system, for subsequent completion of at least 2 system cycles.
    - If no system level testing is to be repeated: the unit is removed, repaired, and retested for a minimum of 10 cycles, prior to reinstallation into the system.

#### 2.6.2.2.3 Mission Risk Classification

GEVS thermal test verification specifications were originally written assuming a low risk project, but have been determined to be directly applicable to higher risk missions, specifically Class C and D, including CubeSats. Separate guidelines have been documented for GSFC CubeSat missions - while acknowledging that the small size and integrated nature of CubeSats may lend itself to completing all cycles at the CubeSat (system) level, the project is to use a risk based approach in determining how much testing is appropriate

Check the GSFC Technical Standards Program website at <http://standards.gsfc.nasa.gov> or contact the Executive Secretary for the GSFC Technical Standards Program to verify that this is the correct version prior to use.

prior to integration vs. conducting all testing at the system level. 12 cycles to protoflight levels (before flight) is still the standard and should be the goal for these projects. Projects with 7120.8 and DNH mission classifications, having higher risk postures, should work with Code 545 to tailor these requirements prior to design/implementation.

#### 2.6.2.2.4 Cryogenic Instruments

The increased development of cryogenic instruments for GSFC missions necessitates detailed considerations of the unique test verification specifications for cryogenic hardware. This section defines the test verification guidelines for hardware operating above 120K using *passive thermal control*. Section 2.7 provides verification guidelines for passive thermal control below 120K and for *active controlled* cryogenic hardware in the < 200K regime.

#### 2.6.2.3 Level of Testing; Test Setup /Configuration

The GSFC thermal verification test approach considers three levels of testing; unit (component), subsystem (instrument), and the system (satellite/vehicle/payload). If it is impractical to test an entire integrated payload, the test may be conducted at the highest practicable level of assembly and ancillary testing and analyses will be completed to verify the flightworthiness of the integrated payload. In cases where testing is compromised, for example, the inability to drive temperatures of the all-up assembly to the qualification limits, additional testing at lower levels of assembly may be warranted.

Typically, the test configuration remains unchanged between thermal vacuum cycling and thermal balance testing, using the same thermal targets and environmental simulators to drive the hardware to protoflight temperatures during the verification cycles, and provide the simulated mission hot and cold environments surrounding the test article for thermal balance testing. Pre-test thermal analysis is required to ensure these targets are designed to meet the requirements of both thermal tests.

A rigorous review of the test setup, including any instrument and/or component stimulators, ensures the test objectives will be achieved and that no test induced problems are introduced. The baseline approach is to test in the full flight configuration, or as close as is practicable, which is described/documented in the test plan/procedure, and is accurately represented in the test thermal model. Test heaters on the payload may be required to achieve proper and safe temperatures.

Understanding that at times allowances have to be made due to various factors, especially at system level, some typical configuration differences from flight might include (but not be limited to):

Solar arrays are rarely included in system level testing, due to their size when deployed, or blockage of critical thermal FOVs when stowed.

Deployed telescopes/sunshields or large deployable antennas/platforms may be too large for a test chamber, requiring separate thermal balance tests for all flight elements or sub-assemblies, and analytical thermal models of the subsystem. Alternately, they may be co-located in the system test chamber, but not in the flight location, so separate and appropriate thermal environments must be provided for them, and accurately modelled.

Propulsion system is empty of fuel for obvious safety reasons, although an inert, surrogate fluid may be considered if deemed necessary for critical transient requirement verification.

If full-up system (Flight Element) thermal vacuum performance verification testing is impractical, due to the sheer scale of the system hardware or facility availability, this means the goal must be to complete the prescribed total of 12 (before flight) thermal vacuum cycles for all flight hardware and the required performance testing and operating times at the lower levels of testing.

If thermal-balance testing cannot be executed at the system level, testing is completed at the next practical lower level of assembly/test, such that all Flight Elements are thermal balance tested, resulting in a

Check the GSFC Technical Standards Program website at <http://standards.gsfc.nasa.gov> or contact the Executive Secretary for the GSFC Technical Standards Program to verify that this is the correct version prior to use.

correlated thermal model for each. These lower level correlated Flight Element thermal models are then integrated into a system thermal model for final system mission predictions. Other metrics such as thermo-optical property measurements of flight coatings, component level tests, and review and verification of manufacturing and installation procedures for thermal hardware are shown to exist which preclude full re-verification testing.

Electronic card/piece part thermal analyses should be performed to ensure that derated junction temperature limits are not exceeded during the expected operational mission conditions. Derated limits are established by EEE-INST-002 or project accepted equivalent. For boxes seeing acceptance, protoflight or qualification temperature levels, margins to vendor  $T_j(\max)$  or alternate level determined by the Parts Control Board (PCB) based on parts screening program should be verified. All flight and test temperature sensors are to be monitored throughout the test and alarmed if possible. These sensors are used to verify the PCB-determined derated temperature limits and to validate the board/unit level thermal analyses and  $T_j(\max)$  margins.

#### 2.6.2.3.1 Unit Testing

Unit level thermal verification testing focuses on performance and functional testing as well as survivability, in a thermal vacuum environment at temperatures extended beyond the AFT range, and proves flightworthiness of the unit. It provides the optimum opportunity for environmental stress screening, and also serves to verify the unit thermal design, especially for units with high dissipations, or gimbals, solar array drives, etc. Unit level testing applies to subsystem/instrument and to system/payload development programs.

Simulating flight-like heat flow and resulting temperatures, units are tested in a flight configuration in thermal vacuum. If the flight thermal control is by conduction only through the mounting surface, unit testing must ensure no additional radiative heat transfer from other surfaces occurs by using blankets, and a conductive mount to a temperature controlled mounting surface provides temperature control. If the unit thermal design relies on radiative heat transfer only, unit level testing simulates this using flight-like coatings, radiative areas, and simulated sinks, and the conductive interfaces are isolated. If both radiative and conductive heat transfer is used, then flight-like representations of both are simulated.

The maximum and minimum temperatures to be imposed during unit level thermal vacuum testing represent, as discussed above, a temperature range large enough, including margins, to induce stress during temperature cycling. The basis for these test temperatures is based on the project established hardware based unit AFT range, plus margins.

Unit level tests cycle the unit through all operational modes to fully characterize the performance and functionality of the unit, testing all electrical and data paths, both primary and redundant. Additionally, units demonstrate turn-on after exposure to hot and cold non-operational limits. Units with internal redundancy, performance and functional testing demonstrate hot and cold starts on primary and redundant circuits and paths. During the test, data is monitored for failures, degradation trends, and intermittent behavior. The unit are powered on and monitored during all temperature transitions, and the health of the unit is monitored and key parameters trended. Performance of the unit is monitored during the test temperature transitions.

#### 2.6.2.3.2 Subsystem Testing

Subsystem level thermal verification testing focuses on subsystem performance verification in modes representative of planned mission operations/functions at temperatures in excess of the extremes predicted for the mission, and during temperature transitions. Thermal balance testing is required at this level for subsystem thermal design verification, while providing temperature and power data for thermal model correlation.

Check the GSFC Technical Standards Program website at <http://standards.gsfc.nasa.gov> or contact the Executive Secretary for the GSFC Technical Standards Program to verify that this is the correct version prior to use.

These tests also provide subsystem stressing cycles to temperatures extended beyond the AFT range, while demonstrating hot and cold turn-on, and satisfactory operation over the range of possible flight voltages. The test article thermal configuration is as planned for flight to maintain flight-like heat flows and provide meaningful thermal balance data and thermal subsystem demonstration.

As an integrated assembly of hardware with different temperature ranges, achieving protoflight temperatures will likely be limited by the hardware with the least robust range, and/or heater control, but the goal should be to achieve as much margin as practicable without violating any individual protoflight limit. Thermal balance testing is required at this level for thermal design verification, while providing temperature and power data for thermal model correlation.

Those subsystems that, at the vehicle level, cannot be tested to their appropriate thermal environments or cannot meet performance testing requirements either due to configuration requirements or interaction with other subsystems, are tested at the subsystem level to include system level verification temperature and cycling requirements, including additional cycles, if necessary.

#### 2.6.2.3.3 System Testing

System level thermal verification testing focuses on system performance verification in modes representative of planned mission operations/functions at temperatures in excess of the extremes predicted for the mission, and during temperature transitions. This test provides the final verification cycles for the units and subsystems, although not all hardware may achieve their individual test limits due to limits imposed by less robust hardware. Additional modes to be tested at this level include launch/ascent (during chamber depressurization), various planned operational modes, safehold, survival, etc. The tests also demonstrate hot and cold “power up” from these minimal power states, and satisfactory operation over the range of possible flight voltages.

As an integrated assembly of hardware with different temperature ranges, achieving protoflight temperatures will likely be limited by the hardware with the least robust range, and/or heater control, but the goal should be to achieve as much margin as practicable without violating any individual protoflight limit. The test article thermal configuration is as planned for flight to maintain flight-like heat flows and provide meaningful thermal balance data and thermal subsystem demonstration. Thermal balance testing is required at this level for final system thermal design verification, while providing temperature and power data for the thermal model correlation.

#### 2.6.2.4 Special Considerations

##### 2.6.2.4.1 Unrealistic Failure Modes

Unrealistic environmental conditions that could induce test failure modes are to be avoided. For instance, hardware characteristics or orbital predictions, are used to limit maximum rates of temperature change to acceptable limits.

##### 2.6.2.4.2 Card Level Analysis Verification

During protoflight testing, specifically at hot plateaus, consideration should be given to monitoring temperature sensors placed at strategic points on electronic cards or piece parts to confirm that the detailed thermal analyses performed were conservative. These temperature monitors can either be flight sensors or test sensors.

##### 2.6.2.4.3 Test Temperature Sensor Location

Test temperatures for a thermal vacuum soak are based on the temperatures at selected location(s) or average temperature of a group of locations, selected in accordance with an assessment to ensure that components or critical parts of the payload achieve the desired temperature for the required time during the

Check the GSFC Technical Standards Program website at <http://standards.gsfc.nasa.gov> or contact the Executive Secretary for the GSFC Technical Standards Program to verify that this is the correct version prior to use.

testing cycle. In some cases, the temperature sensors are attached to the component base plate or to the heat sink on which the component is mounted, if the temperature requirement is defined at the mounting interface.

#### 2.6.2.4.4 Vacuum

Extraneous effects such as gaseous conduction in residual atmosphere should be kept negligible by vacuum conditions in the chamber; pressures below  $1.33 \times 10^{-3}$  Pa ( $1 \times 10^{-5}$  torr) are usually sufficiently low.

#### 2.6.2.4.5 Zero-Q Heaters

Certain test-peculiar conductive paths, such as test cables attached to the thermal balance test article, are controlled so that non-flight-like heat flow into or out of the test article., does not occur. During thermal balance the test cabling is minimized. If possible, hat couplers, stimuli, and other non-flight GSE should not be present during thermal balance testing. At a minimum, necessary test cables are wrapped with multilayer insulation (MLI) for a sufficient distance from the test article. A more positive method of control is to place a guard heater on the test cable a short distance from the test article. Also, place two temperature sensors spanning the interface, one on the spacecraft at the connector, the other on the test cable at the connector, and wrap the cable and heater with MLI over a sufficient distance from the test article. The heater is controlled until the temperatures of the two sensors are the same, thereby minimizing the heat flow through this path.

#### 2.6.2.4.6 Hardware Orientation

The test article must be oriented so that heat pipes are level, or in reflux orientation. Heat pipes, CPLs, LHPs and other two-phase heat transfer devices will be affected by component orientation in the 1g environment, thus limiting a 0g simulation in the test environment. Test planning must provide orientations of flight hardware that position these devices in a gravity neutral or reflux orientation to assure their operation in the test configuration. Hardware levelness or other orientation requirements must be verified in the test chamber, prior to pump down, and actively monitored during the test, to ensure undetected gravity/levelness issues do not degrade performance from this hardware. It is imperative that for instruments with gravity induced effects, the test orientations planned for SCTV be initially tested during the instrument/subsystem level tests.

#### 2.6.2.4.7 Cryogenic Payloads

For cryogenic payloads, chamber walls and/or cryopanel may need to be colder than Liquid Nitrogen temperatures to adequately reject heat. Temperature variations of emissivity should be taken into account in the sink temperature determination analysis.

For active cryogenic control hardware, Code 552 and Section 2.7 should be consulted for specific guidance:

*Dewar Systems:* A test dewar may be necessary to simulate the conditions that a payload would see inside a flight dewar. The cooling in a test dewar is available over the temperature range of approximately 0.3 to 80 Kelvin (with gaps). The dewar system may utilize solid cryogenics, (i.e. Argon, Nitrogen, Neon or Hydrogen) or liquid cryogenics (i.e. helium, nitrogen). During ground testing there is a gravity effect on cryogenics that is not seen in flight. Interfaces between the top of the dewar and the payload may be warmer than what would be seen in flight.

*Coolers:* Thermoelectric Coolers are semiconductor-based electronic components that function as a small heat pump. Heat moves through the module in proportion to the applied voltage. The devices offer active cooling and precise controllability and are used primarily for "spot cooling" (cooling of a single component).

Check the GSFC Technical Standards Program website at <http://standards.gsfc.nasa.gov> or contact the Executive Secretary for the GSFC Technical Standards Program to verify that this is the correct version prior to use.

Coolers are also used to recycle cryogen in a closed loop system. This reduces the amount of cryogen needed during a test. This is frequently done when helium is used to reduce cost.

#### 2.6.2.5 Environment Simulation (General)

By definition, thermal vacuum testing is performed in the simulated thermal and vacuum environments of space. While the pressure is uniformly very low outside of planetary atmospheres, the thermal environment of space varies greatly for near Earth missions, and even more so for interplanetary missions. Although primarily due to the solar intensity, more localized planetary effects (IR emissions, albedo, eclipses) must also be considered, depending on the mission. The geometric complexity and trajectory/orbit/orientation of the flight system throughout the mission, where some parts may be sunlit and exposed to planetary effects and others may be in shadow and exposed to the coldest space temperatures, requires significant analysis to determine these environments for all parts of the hardware.

Once the full set of mission environments is understood, and the bounding hot and cold conditions have been determined for testing, designing the means to simulate them during thermal vacuum testing must be completed. Correctly simulating these environments is required primarily for thermal balance verification of the thermal subsystem, but using these same environments to achieve the required hot and cold test margins during subsystem and system thermal vacuum verification, also influences their design. All of this must be considered early in the test design in order to meet requirements of both types of testing. Further, maintaining the correct environment simulation for subsystems (instruments) during system thermal vacuum and balance testing, is key to successfully validating performance at the system protoflight levels and system thermal performance in the final test in mission environments.

##### 2.6.2.5.1 Unit testing

Usually the simplest test set-up - most electronics units are conductively mounted and radiatively isolated or located in a benign radiation environment, so simulating the thermal environment at this level is primarily done with a temperature controlled mounting surface (platen) used to change the unit interface temperature. Some units and many mechanisms, antennas, and other types of hardware exposed to the external thermal environment, may need to include radiative heat exchange or be blanketed, to accurately simulate the expected flight heat flow and validate the performance in a flight-like thermal environment. Other units, such as lasers, may require optical support equipment during testing. The unique requirements for each type of unit needs to be considered and implemented early in a project to ensure correct testing of hardware at the unit level.

##### 2.6.2.5.2 Subsystem/Instrument testing

Typically heavily dependent on correct environment simulation during thermal balance testing, especially when combining cryogenic and non-cryogenic hardware at this level of assembly, for performance and thermal verification testing. The use of separate thermal "targets" is typical, using liquid and gaseous nitrogen, or helium, as necessary, and may be combined with optical stimulators/calibrators over the aperture(s).

For instruments with two-phase thermal hardware, maintaining common test orientations between subsystem and system testing allows data trending. Similarly, gravity needs to be considered during these tests as some orientations might mask performance issues.

##### 2.6.2.5.3 System/Payload testing

Is usually the most complicated test configuration for performance and thermal verification testing, with large near-ambient temperature spacecraft bus, and several science instruments/sensors, some of which may be cryogenic. Simulating the widely varying thermal environments typically uses a background

Check the GSFC Technical Standards Program website at <http://standards.gsfc.nasa.gov> or contact the Executive Secretary for the GSFC Technical Standards Program to verify that this is the correct version prior to use.

radiative sink (cold shroud) and numerous localized thermal “targets” is typical, using liquid and gaseous nitrogen, or helium, as necessary, sometimes combined with optical simulators/calibrators over instrument apertures. Accurately simulating the interfaces and backload heating effects on the instruments can be critical at this level.

#### 2.6.2.5.4 Type of Simulation

The methods available to simulate environmental conditions are generally determined by the size of the chamber, and the payload. The project test engineer should try to achieve the highest practical order of simulation; that is, the one that requires the minimum number of assumptions and calculations to bound the flight worst case thermal environment. The closer the simulation is to the spectrum, intensity and the worst case environments, the less reliance on the thermal analytical model to verify the adequacy of the thermal design. The effects of shadowing, blockage, and/or reflections (both diffuse and specular) in the flight and test configurations are assessed and determined to be needed for an accurate simulation, or are artifacts that could adversely affect the simulation. While an overall radiative sink temperature can be achieved by using the chamber shroud and varying its temperature, it usually does not provide sufficient controllability to allow different environments (sink) around the test article, as in most missions. Numerous individual thermal targets could be used for all primary thermal control surfaces surrounding the test hardware, but at higher levels of assembly this can become very complicated and difficult to implement correctly and safely. Note that surfaces covered with Multi-Layer Insulation, if sufficiently large may contribute significantly to the heat flow and require heating/cooling sources to correctly simulate the expected mission environments and heat flow.

The optimum approach typically utilizes localized, discrete heating (thermal targets) around the test article, with a background cold radiative sink – the chamber shroud – to create an effective radiative “sink temperature” that is determined based on the predicted mission environmental heating of the surfaces of the test article. Typical temperature regime capabilities of thermal vacuum chambers are:

- |  |             |
|--|-------------|
| (1) Controlled with Gaseous Nitrogen (GN <sub>2</sub> ): | ~ 170-375 K |
| (2) Flooded with Liquid Nitrogen (LN <sub>2</sub> ):     | ~ 80-90 K   |
| (3) Liquid Helium (LHe):                                 | 20-30 K     |

Methods of simulation and the major assumptions for a successful test are described below:

##### 2.6.2.5.4.1 Radiative Sink Temperature

An effective sink temperature is calculated using spacecraft thermal math models that encompass the effects of solar, Earth IR, albedo and IR effects from other spacecraft surfaces (i.e. backloading), with the appropriate correction for gray body radiation. Test and flight predicts of the energy flow from critical surfaces should be compared. Predictions of both the energy flow and temperatures from the test model should be at least as severe as calculated in the flight model.

##### 2.6.2.5.4.2 Cryopanels

Sink temperatures for individual radiators and critical thermal control surfaces can be controlled with cryopanel. Cryopanel for cryogenic systems may require special enhancements, for example, open-face honeycomb radiators to increase emittance values, using fluids noted above. Temperatures in between those regimes can be achieved using heaters added to the cryopanel, or a heater plate that is conductively coupled to the cryopanel, or combined with quartz lamps or calrods (see below).

##### 2.6.2.5.4.3 Radiator Heaters

For simply shaped payloads, the absorbed energy from all exterior sources as determined by analysis, is simulated at the exterior surface of the payload (usually the radiators) using I<sup>2</sup>R heaters. Although this

Check the GSFC Technical Standards Program website at <http://standards.gsfc.nasa.gov> or contact the Executive Secretary for the GSFC Technical Standards Program to verify that this is the correct version prior to use.

approach can be useful for thermal-cycling, this is not a valid thermal balance approach and does not allow verification of the thermal control coatings emittance, requiring measurement before flight to ensure accuracy of the model. Also, the project must understand that these heaters must be removed before flight, and any underlying thermal control material/coating will likely be damaged, requiring repair or recoating before flight.

#### 2.6.2.5.4.4 Heater Plates

This is one of the most used methods of simulating the thermal environment, especially if the payload outer surfaces are not to be touched. The same information is needed for the plates as for the skin heaters and the exchange factor between the plates/cryopanel and the payload must be known. In both cases, a balance equation considering absorptivity, emissivity, incident and rejected energies must be solved to establish accurate test conditions. Pre-test analysis must be used to optimize the size/location of these plates to ensure accurate simulation and to provide flexibility in achieving protoflight test levels.

#### 2.6.2.5.4.5 Fluid Coldplates

Similar to heater plates, a fluid coldplate typically allows a wider temperature range on the cold end, depending on the fluid used. The same information is needed for the plates as for the skin heaters and the exchange factor between the plates/cryopanel and the payload must be known. In both cases, a balance equation considering absorptivity, emissivity, incident and rejected energies must be solved to establish accurate test conditions. Again, pre-test analysis must be used to optimize sizing/location.

#### 2.6.2.5.4.6 Quartz lamps/calrods

This is an acceptable method of simulating planetary and solar heating, so long as the differences in spectral output are measured and the input is adjusted. Care must be taken to understand the spectral distribution of energy due to the high temperature of the emitting source, and thermo-optical properties adjusted appropriately. While the spectral mismatch does not significantly affect the emissivity, the effect on the absorptivity can be large and should therefore be determined and compensated for in the test and/or analysis. One technique used to monitor and control lamps is to place calorimeters<sup>1</sup> at the surface of the payload to measure the incident energy from the lamps. For hardware safety reasons, since these are typically very high power, electrical fusing and cabling must account for conceivable failure modes, and the test set-up should avoid exposed terminals.

#### 2.6.2.5.4.7 Solar Simulation

Solar inputs can be simulated by mercury-xenon, xenon, or carbon arc source, cryopanel, and/or heaters as described below. The spectrum and uniformity of the source used to simulate the sun and planet albedo must be thoroughly measured and understood through pre-test measurement. Again, calorimeters are effective in measuring simulated solar fluxes.

#### 2.6.2.5.4.8 Atmospheric Simulation

For systems or subsystems that will operate in partial atmosphere, such as Mars surface experiments, testing should include the same atmospheric conditions, to the maximum extent practical.

#### 2.6.2.5.4.9 Conductive interfaces

---

<sup>1</sup> Calorimeters are passive, in-situ temperature measurement devices, using thermocouples attached between an outer (sink facing) layer of same material as the test article, and isolated on the reverse side from the test article by MLI. Calorimeter design must carefully address parasitic heat paths to ensure accuracy, especially at low temperatures.

Temperatures may be simulated with cold plates that are held at worst-case boundary conditions. Their temperature can be varied for cold flight, hot flight, and safe-hold conditions or parametrically varied. Since the payload must be mechanically supported during testing there is generally a non-flight conductive heat flow path that is, in flight, a radiative interface, usually with the space environment (e.g., the launch vehicle attachment interface). As much conductive isolation as possible should be used between the test article and this non-flight conductive interface. A heater is placed on the test fixture side of such a conductive interface and two temperature sensors spanning the interface are used. The heater is controlled until the temperatures of the two sensors are the same, thereby minimizing the heat flow through this path. Without good isolation here, it is likely that an unrealistic and hard to quantify bias will be introduced at this interface, making the test results difficult to assess. Isolation is typically achieved by using low thermal conductance standoffs. However, the payload may need to be suspended with low conductance cables if the system has a high sensitivity to small heat flows. Similarly, heat flows to/from large cable bundles during test must be considered and minimized to achieve accurate thermal balance conditions.

The setup for testing, including any instrument and/or component stimulators, is designed/configured to ensure that the test objectives will be achieved, and that no test induced problems are introduced. All subsystem and system test configurations are documented and described in test plans and test procedures, with the test hardware in flight configuration, as nearly as practicable, and reflected in the test thermal model. Test heaters on the payload may be required to achieve proper and safe temperatures.

All flight and test temperature sensors are alarmed and continuously monitored throughout the test. The operational modes of the payload are monitored in accordance with Section 2.3.

#### 2.6.2.6 Tailoring

As noted in Section 1.3, GEVS is written as an endorsement of GSFC's heritage verification approach in which the entire payload is tested or verified under conditions that simulate the flight operations and flight environment as realistically as possible. While it acknowledges tailoring of these standards may be necessary in "unavoidable exceptions, or conditions which make it preferable to perform the verification activities at lower levels of assembly", or "to reflect hardware characteristics such as physical size and complexity", such tailoring must be done with concurrence of the technical authority, and documented at MCR/SRR. While contingencies late in the development cycle may force deviation from these fundamental specifications to maintain cost, or schedule, the baseline verification plan should follow this approach. The project should proactively work with the technical community early in the development cycle to generate a rigorous test plan in line with mission success.

#### 2.6.3 Thermal Vacuum Verification

In lieu of a traditional qualification-acceptance test verification program, the Goddard Space Flight Center utilizes a "protoflight qualification" ("proto-qualification") thermal test program, where reduced test levels (temperature range) allow the test hardware to be available for flight. Further reduction in temperature range to "acceptance" levels for post-protoflight hardware (follow-on, spares, etc) reduces the workmanship screening effectiveness. It is recommended that for projects with multiple flight units, elements or systems, all hardware be tested to protoflight levels, rather than reducing test specifications for "follow-on" units. Table 1 illustrates the prescribed operational temperature test margins. Design margins required are included in the prediction of the expected flight temperatures and margined predictions must be within the allowable temperature range. Unit survival limits should be defined by the hardware limits, and should be at/or outside the protoflight temperature range of the hardware.

##### 2.6.3.1 Requirements

The heritage verification approach has been developed for the three levels of testing typically considered; the unit (component), subsystem (instrument), and the system (payload/spacecraft), based on the test parameters available: test levels, number of cycles and transition rate. If it is impractical to test an entire

Check the GSFC Technical Standards Program website at <http://standards.gsfc.nasa.gov> or contact the Executive Secretary for the GSFC Technical Standards Program to verify that this is the correct version prior to use.

integrated payload, the test may be conducted at the highest practicable level of assembly, along with any ancillary testing needed. In this scenario, the final verification and flightworthiness of the integrated payload will be based on an integrated set of analyses.

In cases where testing is compromised, for example, the inability to drive temperatures of the all-up assembly to the qualification limits, testing at lower levels of assembly may be warranted. For units/sub-assemblies not included in system level thermal vacuum testing, lower level testing must be used to complete the total pre-flight cycle quantity before final system integration.

Above the unit level of assembly, it becomes more difficult to achieve individual protoflight temperatures on all hardware that typically has very different allowable ranges, yet are often located in close proximity to each other. This usually results in a unit with a less robust temperature range limiting the achievable temperature of adjacent units having more robust ranges, thus under-testing some hardware while not over-stressing others. To better achieve the required workmanship screening, options may be considered to complete all workmanship stress screening cycles at the unit level where individual protoflight temperatures are easily achieved and cycling time is minimal, allowing subsystem and system level testing to focus more on demonstrating performance at test temperature levels appropriate to those levels of assembly. In this scenario, subsystem and system level cycles may be reduced, as long as a minimum of twelve before flight is met.

### 2.6.3.2 Test Parameters

Test/workmanship margin, temperature cycling, soak duration, test chamber conditions, transition rates, temperature and pressure regimes, are some of the key parameters of the environmental verification test. Overall test effectiveness is primarily affected by the test temperature range, number of cycles, and temperature-rate-of-change. Specifications for passive cryogenics systems operating <120K, are discussed under each of these parameters, while active cryogenic systems are covered in Section 2.7.

#### 2.6.3.2.1 Test Margins

Temperature margins are established to demonstrate performance beyond where units are allowed to operate (AFT) in flight and to induce sufficient thermal stress conditions to detect unsatisfactory performance that otherwise may not be discovered before flight. The basis for these test temperatures is the individual unit operational and non-operational limits that are based on hardware capability, not thermal analysis predictions, and are as broad as possible. For instrument/subsystem and spacecraft level testing, the minimum and maximum temperatures imposed is derived from the collection of various unit temperature ranges, while acknowledging the least robust range.

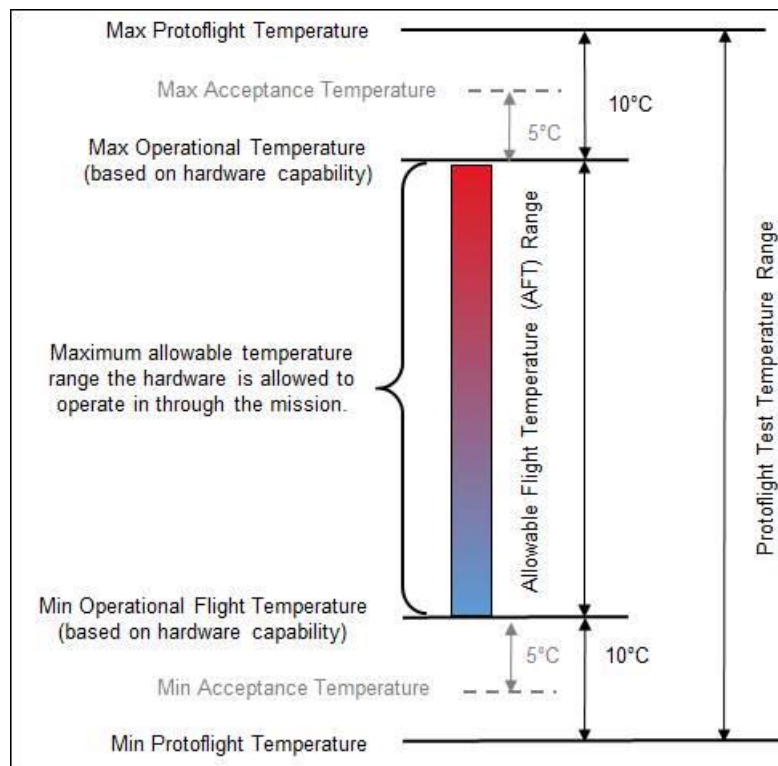

**Figure 2.6-1 - Thermal-Vacuum Test Temperatures Margins (Passive Thermal Control)**

#### 2.6.3.2.1.1 Non-Cryogenic hardware (>120K)

For all units, a test temperature margin of no less than 10°C is imposed on the unit level operational temperature range (AFT) at all levels of testing (Figure 2.6-1).

At subsystem/system level, for hardware not actively controlled directly by heaters or other thermal hardware, the test temperature margin achievable is dependent on the collection of unit protoflight ranges (often limited by the least robust range); a minimum of 15°C outside of the predicted mission temperature ranges for the various units defines the "subsystem or system protoflight" condition.

At subsystem/system level, for hardware actively controlled by heaters or other thermal hardware whose temperature control range is not selectable/variable such that the control system will not allow the hardware to be stressed via temperature at the hot or cold end, then test margin to be demonstrated is as determined by the control range. (Note: thermal balance testing must demonstrate design margin as described in Section 2.6.4.3)

For subsystems/systems having units with redundant, fixed temperature (setpoint) operational heater control, the cold end margin for unit level testing of those units may be reduced from 10°C to 5°C, as long as the heater control duty cycle requirement (Section 2.6.4.1) is met. Higher level testing with the heater control enabled need not attempt to drive the hardware below the setpoint.

Units not directly heater controlled must provide 10°C cold test margin.

**Actively Controlled Hardware (>120K):** For components/subsystems/payloads with active thermal control, such as Thermo-Electric Coolers (TECs), Loop Heat Pipes (LHPs), Capillary Pumped Loops (CPLs), or other devices controlled using heaters with selectable/variable set points, the required range of

Check the GSFC Technical Standards Program website at <http://standards.gsfc.nasa.gov> or contact the Executive Secretary for the GSFC Technical Standards Program to verify that this is the correct version prior to use.

temperature control is demonstrated in the worst hot (minimum setpoint) and worst cold (maximum setpoint) thermal environments during thermal balance testing.

For subsystems/systems having units with variable/selectable temperature operational heater control, the goal should be to drive the hardware +/-10°C and no less than 5°C from the nominal setpoint.

#### 2.6.3.2.1.2 Cryogenic Hardware (<120K):

The 10°C thermal vacuum protoflight test margin should be the goal for cryogenic hardware (such as detectors), especially in the upper end of the cryogenic range, noting that the full 10°C may not be possible for some passive cryogenic systems, in the extreme cryogenic range, due to test setup limitations, and performance testing limitations outside the normal temperature range. These limitations on margins should be established in collaboration between the Project and ETD Thermal Engineering based on the unique characteristics of the test article, and documented by System Requirements Review. Additional information about cryogenic test margins is contained in Section 2.7.3.4.

For cryogenic hardware that is actively controlled by ADRs, dewars, etc, refer to Section 2.7 or contact Code 552.

#### 2.6.3.2.2 Thermal Vacuum Cycle Quantity

Cycling between temperature extremes has the purpose of checking performance during both stabilized conditions and transitions thereby causing temperature gradient shifts, thus inducing stresses that are intended to uncover incipient problems. The number of cycles is not based on the expected temperature cycles during the mission, but is intended to induce a prescribed amount of thermal stress in the test hardware.

##### 2.6.3.2.2.1 Non-Cryogenic hardware (>120K)

For all flight hardware, a minimum of 12 cycles before flight is prescribed, achieved at each of the lower levels of assembly as discussed in Section 2.6.2.6.

Table 2.6-1 summarizes these generic test parameters, applicable to all missions at GSFC, for thermal verification of non-cryogenic hardware at the unit, subsystem, and system levels of assembly:

**Table 2.6-1 -Thermal Vacuum Verification Summary (Non-Cryogenic)**

<b>Test Parameter</b>	<b>Unit</b>	<b>Subsystem / Instrument</b>	<b>System / Satellite<sup>(2)</sup></b>
<b>TV Cycle Qty ( preferred )<sup>(1)(2)</sup></b>			
<b>Subsystem / Instrument:</b>	4 (0)	4 (8)	4
<b>System / Payload:</b>	8	N/A	4
<b>TV Cycle Qty (alternate)<sup>(1)(2)</sup></b>			
<b>Subsystem / Instrument:</b>	6	4	2
<b>System / Payload:</b>	10	N/A	2
<b>Test Temperature Margin<sup>(3)</sup> (Figure 2.6-1)</b>	AFT range +/-10C	AFT range +/-10C <sup>(5)</sup>	AFT range +/-10C <sup>(5)</sup>
<b>Plateau Duration (hrs)<sup>(4)</sup></b>	4	12	24
<b>Maximum Transition Rate (°C/min)<sup>(6)</sup></b>	1.0	1.0	1.0

Check the GSFC Technical Standards Program website at <http://standards.gsfc.nasa.gov> or contact the Executive Secretary for the GSFC Technical Standards Program to verify that this is the correct version prior to use.

## Notes:

1. The goal for workmanship screening is a minimum of 12 cycles before flight; the preferred approach is the GSFC heritage protoflight, with the system test providing the final four (4) cycles for all flight hardware, and instrument hardware completing 8 cycles before delivery to system I&T (a minimum of four (4) of those cycles must be performed at the subsystem/instrument level of assembly). If the project desires to reduce subsystem and/or system cycle quantity, an alternate approach is offered, requiring additional workmanship screening cycles at the lower levels, rather than under-testing the flight hardware.
2. Due to stabilization time constraints of cryogenic hardware, refer to Section 2.6.2.3
3. Actively controlled cryogenic hardware should refer to Section 2.7. Test and design margins for passively controlled cryogenic hardware are addressed in this section of GEVS.
4. These are estimates of the soak time initialized after achieving specified stabilization criteria, to allow completion of the planned testing at each plateau. Pre-test thermal analysis must confirm these durations, or modify them as needed so long as stabilization and test requirements are met. They may also need to be extended to meet total vacuum operating time requirements at hot and cold plateaus.
5. Temperatures achieved may be the same as individual unit protoflight temperatures, but should be at least 10°C beyond worst case hot & cold mission *margined* temperatures predictions (already includes the 5°C design/uncertainty margin).
6. These are suggested rates, which may be easily achievable at unit level, but complicated by thermal isolation and/or larger thermal mass at higher levels of assembly. Project specific rates achievable in test should be determined analytically by PDR, compared to mission transition rates, and implemented in test and/or procurement specifications.

Based on testing derived by other branches at GSFC, specifically Code 543 (Mechanical Engineering) and Code 597 (Propulsion), the following hardware specific cycling specifications may apply:

<u>Hardware</u>	<u>Cycle Qty</u>	<u>Comments/Notes</u>
Structure:		
Metallic	2 (min)	if structural margins are driven by thermal stresses; recommend complete alignment performance test prior to instrument assembly, for optically sensitive structure
Bonded/bolted	2 (min)	Recommend complete alignment performance test prior to instrument assembly, for optically sensitive structure,
Bonded only	2 (min)	if primary load path; no cycles needed if secondary structure, unless structural margins are driven by thermal stresses
Radiator panels	4 (min)	no embedded thermal hardware
	4 (min)	with embedded thermal heat pipes, LHPs, etc. Also requires IR imaging (Section 2.6.4.4)
Propulsion:		
Static	not required	Tanks, lines, filters, fittings, venturis
	8 <sup>b</sup>	pressure transducers
Dynamic	1 <sup>d</sup>	non-electronic hardware (regulators, fill & drain valves)
	8 <sup>a,b,c,d</sup>	electronic (w/solenoids or other EEE parts), i.e. –valves, including thrusters

## Notes:

- a) Dynamic electronic components must demonstrate the pull in voltage at hot and cold plateaus (to identify force margins)
- b) All electronic components should demonstrate in qualification the amount of time they can withstand the maximum voltage
- c) Engines should have validated hot fire models, no dedicated cycle testing is required
- d) Functional testing must be performed at the hot and cold extremes

If thermal cycle testing is being performed as a performance or workmanship screen for mechanical hardware and the hardware does not contain any heat generating components, it is acceptable to perform

Check the GSFC Technical Standards Program website at <http://standards.gsfc.nasa.gov> or contact the Executive Secretary for the GSFC Technical Standards Program to verify that this is the correct version prior to use.

thermal cycle testing under ambient pressure conditions. The number of cycles for this type of testing may be less than the minimum of the 8 thermal-vacuum cycles required for qualification. The number of cycles should follow the guidelines shown in the above table. Examples of where these reduced requirements may be applied are when thermal-cycling a honeycomb panel with bonded inserts to verify integrity under thermal loading or during testing of a mechanism to verify operation at temperature extremes.

#### 2.6.3.2.2 Cryogenic hardware (<120K)

The baseline cycling specification may not apply to cryogenic systems, due to time constraints and may cause undue stress on flight systems. While long transitions to cryogenic temperatures may have structural effects on passive cryogenic hardware, operational conditions must be considered when determining cryogenic system cycling quantity. The number of cycles is established in collaboration between the Project and structural and thermal engineers based on the unique characteristics of the test article, and documented at System Requirements Review (Note: parts of the subsystem/instrument not considered cryogenic must still complete the baseline number of cycles before system level integration), requiring test targets/thermal control to achieve this. Additional information about cryogenic cycling is contained in Section 2.7.3.4b.

#### 2.6.3.2.3 Plateau Durations

The duration of each of the test plateaus, at any level of testing, is sufficient to complete the required performance testing to demonstrate performance and uncover early failures, and to meet required hot and cold operating times. The plateau test time may vary based on such factors as the number of mission-critical operating modes, the test item thermal inertia, required operating time at temperature, and test facility characteristics.

Unit testing: temperature soaks and dwells time begin when the “control” temperature, usually the baseplate or platen, is within 2°C of the protoflight test temperature. Hot and cold operational plateaus are a minimum of 4 hours in duration, or the time needed to complete performance testing, whichever is greater, while non-operating plateaus are held for a minimum of 2 hours.

Subsystem testing: temperature soaks and dwell time begin when 98% of the temperature sensors on the test article are within 2°C of the expected test temperature, or are changing <0.1°C/hour, and are held for a minimum of 12 hours in duration (both hot and cold operational plateaus) or the time needed to complete performance testing, whichever is greater. Survival/safehold plateaus are maintained a minimum of (8) hours at proper temperature conditions.

System testing: temperature soaks and dwell time begin when 98% of the temperature sensors on the test article are within 2°C of the expected test temperature, or are changing <0.1°C/hour, and are held for a minimum of 24 hours in duration (both hot and cold operational plateaus) or the time needed to complete performance testing, whichever is greater. Survival/safehold plateaus are maintained a minimum of (8) hours at proper temperature conditions.

#### 2.6.3.2.3.1 Cryogenic Hardware

The plateau durations for cryogenic elements may be significantly longer than noted above. Plateau start times and durations should be established by cognizant engineers based on the settling time, operational characteristics/limits, and verified via thermal analysis.

Check the GSFC Technical Standards Program website at <http://standards.gsfc.nasa.gov> or contact the Executive Secretary for the GSFC Technical Standards Program to verify that this is the correct version prior to use.

#### 2.6.3.2.4 Pressure

The chamber pressure after the electrical discharge checks are conducted is less than  $1.33 \times 10^{-3}$  Pa. ( $1 \times 10^{-5}$  torr). The ability to function through the voltage breakdown region is demonstrated during pump down, and/or repressurization, if applicable to mission requirements (those elements that are operational during launch).

Hardware operating in partial pressures, such as surface experiments on Mars, are tested in all mission environments that they operate in, including vacuum and partial pressure(s), as applicable.

#### 2.6.3.3 Demonstration

##### 2.6.3.3.1 Electrical Discharge Check

Items that are electrically operational during pressure transitions undergo an electrical discharge check to ensure that they will not be permanently damaged from electrical discharge during the ascent and early orbital phases of the mission, or during descent and landing (if applicable). The test is designed to include checks for electrical discharge during the corresponding phases of the vacuum chamber operations, typically pumpdown and/or repressurization.

##### 2.6.3.3.1.1 Outgassing Phase

If the test article is contamination sensitive (or if required by the contamination control plan) an outgassing phase must be included to permit a large portion of the volatile contaminants to be removed. The outgassing phase will be incorporated into a hot exposure that will occur during thermal-vacuum testing. The test item will be cycled hot and remain at this temperature until the contamination control monitors indicate that the outgassing has decreased to an acceptable level.

##### 2.6.3.3.1.2 Hot Conditions

The temperature controls are adjusted to cause the test item to stabilize at the upper test temperature. Hot turn-on capability is demonstrated as required. The duration of this phase is sufficient to permit the performance of the functional tests with a minimum soak time as specified in Table 2.6-1.

##### 2.6.3.3.1.3 Transitions

The test item remains in an operational mode during the transitions between temperatures so that its functioning can be monitored under a changing environment. The requirement may be suspended when turn-on of the test item is to be demonstrated after a particular transition. Although flight-like heat paths should be maintained, in certain cases it may be possible to expedite transitions by removing thermal insulation to expedite cool-down rates. Caution must be taken not to violate temperature limits, or to induce test failures caused by excessive and/or unrealistic gradients or transition rates.

At unit level, temperature transitions should be as robust as possible, as suggested in the table above. At higher levels of assembly, the additional thermal mass and larger time constant will tend to "self-limit" achievable rates, although a goal should be to at least achieve flight-like rates. The rate of transition specified ensures that stresses caused by thermal gradients will not damage the test article. STOP (Structural/Thermal/Optical) analyses should be performed to ensure stresses and alignments are acceptable for the given transition rate. Care must be exercised with cryogenic systems where the thermal stresses can be severe. The cool-down and warm-up for cryogenic systems should be as flight like as possible. Contamination effects may also be a factor.

##### 2.6.3.3.1.4 Cold Conditions

Check the GSFC Technical Standards Program website at <http://standards.gsfc.nasa.gov> or contact the Executive Secretary for the GSFC Technical Standards Program to verify that this is the correct version prior to use.

The temperature controls are adjusted to cause the test item to stabilize at the lowest test temperature. Cold turn-on capability is demonstrated at the start of the cold condition, and the duration of the cold phase is sufficient to permit the performance of the functional tests with a minimum soak time as specified in Table 2.6-1.

#### 2.6.3.3.1.5 Hot and Cold Start Demonstrations

Start-up capability is demonstrated to verify that the test item will turn on after exposure to the extreme temperatures that may occur in orbit. Turn-on capability is demonstrated under vacuum at least once at both the low and high temperatures, on primary and redundant side, as applicable. Test turn-on temperatures are defined by the expected mission operations without any margin; that is, temperatures should be at either survival/safe-hold or qualification temperature conditions, whichever are more extreme, as appropriate.

Unit/Component: this demonstration is performed after exposure to non-operating temperatures, or the protoflight temperatures, whichever is more extreme. Cold turn-on typically follows exposure to the cold non-operating temperature, or the protoflight temperature, whichever is more extreme. Hot turn-on typically follows the bakeout plateau, allowing the unit to cool to the hot protoflight limit (if less than the bakeout temperature) before turn-on.

Subsystem/Instrument: this demonstration is consistent with the scenario regarding which units/components are actually power cycled (off/on) in orbit, and also for recovery from a survival/safe-hold mode in orbit.

Payload/Spacecraft: this demonstration is consistent with the scenario regarding which units/components are actually power cycled (off/on) in orbit, and also for recovery from a survival/safe-hold mode in orbit.

For example, recovery from cold survival/safehold temperatures to cold operational temperatures may be accomplished either by using a flight heater, or alternately, by turning the units/components of the test item back on and allowing internal dissipation to warm temperatures. Proper operation is then checked after the component has returned to the protoflight limit. The duration of the soak with the test item off, or in survival/safe-hold mode, is in accordance with Table 2.6-1.

#### 2.6.3.3.1.6 Functional Test

Functional tests are performed at each hot and cold soak plateau and during transitions. A comprehensive performance test (CPT) is performed at least once during hot plateau(s) and once during cold plateau(s), exercising complete primary and redundant operations, unless it is determined to be impractical. In that case, with project approval, a limited functional test may be substituted if satisfactory performance is demonstrated for the major mission critical modes of operation. Otherwise, the requirements of 2.3.2 apply. Functionality and performance of the thermal control system hardware is demonstrated during the thermal-balance portion of the test.

#### 2.6.3.3.1.7 Return to Ambient

If the mission includes a requirement for the test item to remain in an operational mode through the descent and landing phases, the test segment is included to verify that capability. If possible, the test article should be kept warmer than the surroundings to protect against contamination from the test facility. Before the chamber can be backfilled with air, all sensors should read above the dew point to insure that water does not condense on the payload.

Check the GSFC Technical Standards Program website at <http://standards.gsfc.nasa.gov> or contact the Executive Secretary for the GSFC Technical Standards Program to verify that this is the correct version prior to use.

2.6.3.3.1.8 General

The margins, soak criteria, cycling, and duration guidelines listed above apply primarily to test articles around room temperature (except where noted). Test parameters for high temperature and cryogenic systems should be determined early in the program by Code 545, Code 552 (in the case of cryogenic systems) and the project engineering and science teams. Notional test profiles summarizing some of the above parameters are shown in Figure 2.6-2 for unit, subsystem/instrument, and system/satellite level thermal vacuum testing. Thermal models should be used to estimate transition and stabilization times. The “control” temperature criterion for cryogenic systems should be determined by the thermal engineer and the Project as it may be significantly more stringent than 2°C.

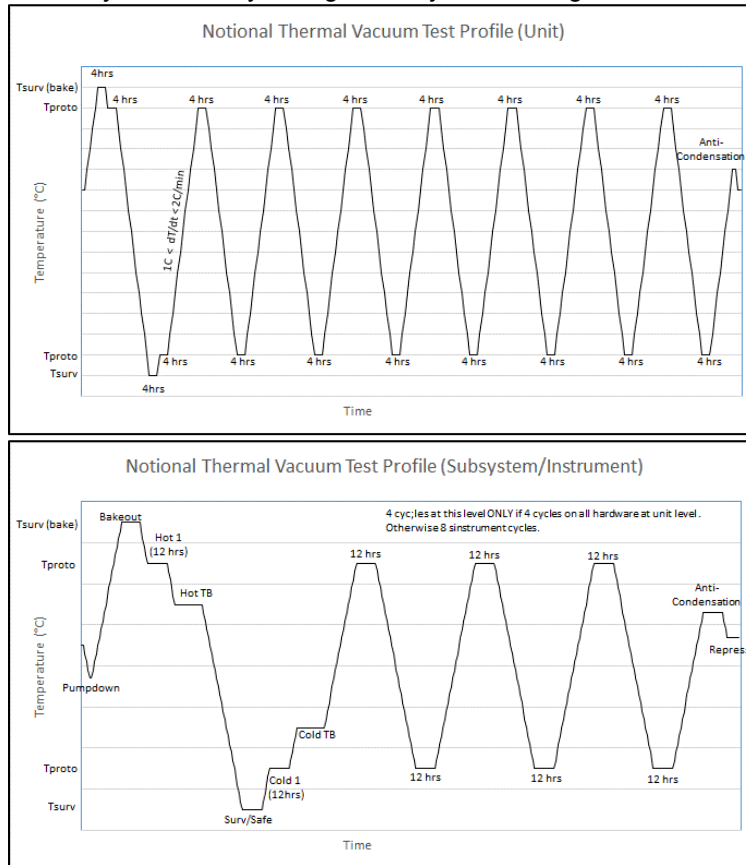

Check the GSFC Technical Standards Program website at <http://standards.gsfc.nasa.gov> or contact the Executive Secretary for the GSFC Technical Standards Program to verify that this is the correct version prior to use.

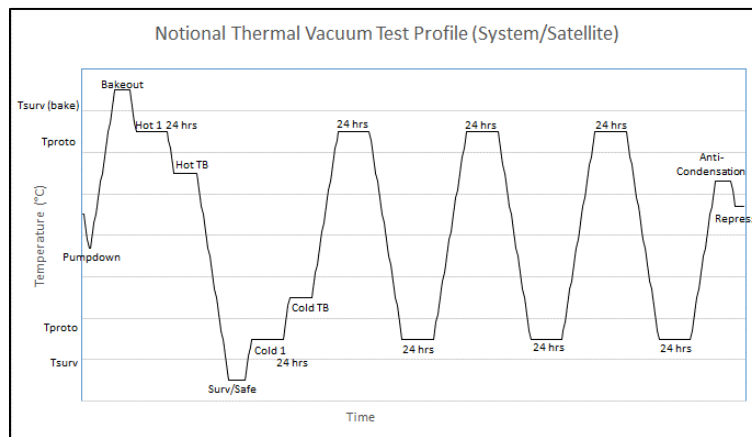

**Figure 2.6-2 - Notional TV Test Temperature Profiles (Unit, Subsystem, System Level)**

#### 2.6.3.4 Special Tests

Special tests may be required to evaluate unique features, such as a radiation cooler, or to demonstrate the performance of external devices such as solar array hinges or experiment booms that are deployed after the payload has attained orbit.

The test configuration reflects, as nearly as practicable, the configuration expected in flight. When items undergoing test include unusual equipment, special care must be exercised to ensure that the equipment does not present a hazard to the test item, the facility, or personnel. Special tests must be included in the project environmental verification specification (1.10.2).

#### 2.6.3.5 Environment Simulation (TV)

As noted in paragraph 2.6.2.5, using the same test set-up and thermal/optical targets in subsystem and system thermal vacuum testing is desirable for cost reasons, although additional thermal targets or heating methods may be used to fully achieve test goals at subsystem or system level.

Thermal analyses of the test set-up, including planned targets and environmental simulation, must be completed to ensure acceptable protoflight levels are achieved.

#### 2.6.3.6 Acceptance Requirements

Testing at all levels of assembly, is considered successful if:

2.6.3.6.1 Test Levels Achieved: The predicted test levels (temperatures) are achieved (within tolerance) for all relevant hardware. Any exceedances must be documented in the appropriate anomaly database and vetted for the associated hardware's continued availability for flight.

Performance: Unit Level:

Further, following unit, subsystem, and system level testing:

2.6.3.6.2 Failure-Free-Performance: At least 100 trouble-free hours of functional operations at the hot conditions, and 100 trouble-free hours of functional operations at the cold conditions must be demonstrated in the thermal verification program. It is noted that a total of 350 hours of failure-free hours is a requirement of which 200 are to be in vacuum. (Section 2.3.4).

Check the GSFC Technical Standards Program website at <http://standards.gsfc.nasa.gov> or contact the Executive Secretary for the GSFC Technical Standards Program to verify that this is the correct version prior to use.

## 2.6.4 THERMAL BALANCE VERIFICATION

Thermal balance phases, performed as part of subsystem/instrument or system/space vehicle thermal vacuum testing, are used to verify thermal design and hardware performance guidelines<sup>2</sup>, including heater operation, radiator sizing, thermal blanket performance, and critical heat transfer paths, while providing temperature and power data to be used in correlating the analytical thermal model(s) that will be used for mission operations. Thermal subsystem performance verification can only be demonstrated in thermal vacuum testing, with test phases designed to operate the flight hardware in various flight-like modes, while exposed to the simulated worst hot and cold environments expected for the mission.

Pre-test analysis is performed using the element or system thermal model to aid in test design and to assure hardware safety. The test model is correlated to test data to generate the model used for delivery (instrument) or launch (system).

The test objectives are to validate the thermal design and to verify functional performance by:

1. Verifying that the flight hardware system thermal control design satisfies the AFT, thermal gradient, and thermal stability requirements under a combination of extreme simulated mission thermal environmental and operational conditions

2. Collecting sufficient data to enable thermal math model correlation so that untestable conditions can be validated by analysis

While the actual thermal balance test scenarios for each mission may be unique and are to be determined by the project thermal engineer, a minimum of three test conditions are imposed:

- Operational hot case, with maximum environmental conditions and maximum power configuration
- Operational cold case, with minimum environmental conditions and minimum power configuration
- Survival:
  - o Subsystem/Instrument: Non-operational case (subsystems/instruments), with minimum environmental conditions
  - o System/Satellite: Survival or Safe Mode, with minimum environmental conditions and appropriate power configuration.

Additional cases to be considered include: a transient case to check the thermal time constant of the model, safe mode, and nominal “day-in-the-life” conditions. Short-term, mission-like, transient simulations may be warranted, especially if the units are operating near their limit, and these should be added at the end of the appropriate steady state thermal balance plateau after stability is declared.

### 2.6.4.1 Guidelines

The principal goal of thermal balance testing is to verify thermal design margins in worst case expected hot and cold thermal environments, by demonstrating thermal subsystem performance while simulating operational and safhold/survival environmental conditions for the mission. For example, these design margins include:

- Thermal design (uncertainty) margin: accounts for lingering error between correlated model temperature predictions and actual temperatures seen in flight. Typically, for non-cryogenic hardware at GSFC, this is implemented by reducing the Allowable Flight Temperature range by 5°C (hot and cold limits), creating an analytical prediction range, that encompasses all worst-case temperature predictions

---

<sup>2</sup> See branch documentation 545-PG-8700.2.1 for specific thermal design requirements

*Cryogenic:* The increased number of cryogenic payloads necessitates an updated definition of design margin. The GSFC Cryogenics Branch (Code 552) has recently updated the prescribed design uncertainty margins to be used on all cryogenic projects throughout the development cycle.

For passive cryogenic systems, the design margin is expressed as heat load margin<sup>3</sup> and recent guidelines show how this margin can be reduced<sup>4</sup> as a function of design maturity from project start through launch readiness. See Table 2.7-2.

Heat load margins are applied to the current best estimate of the cryogenic heat loads, including parasitics; and applied at the location in which they are incurred.

Margin% = (Cooling Capability – Current Best Estimate) / Current Best Estimate

For the prescribed 33% margin (at PSR/launch), a heat rejection calculation below 120K shows the commensurate temperature margins:

$T_{\text{MARGIN}}$ (K)	$T_{\text{PREDICT}}$ (K)
5K	103 - 120K
4K	81 - 103K
3K	59 - 81K
2K	35 - 59K
1K	14 - 35K

Therefore, *thermal design margin* is applied as 5K temperature margin above 120K, and as the prescribed heat load margin below 120K, or the approximate commensurate temperature margin noted above.

- *Operational heater duty cycle margin* (or equivalent for “non-ON/OFF” control); less than 70% duty cycle in worst cold case, using appropriate minimum voltage as established by the project, including line losses.
- *Survival heater duty cycle margin*, dependent on survival setpoint/temperature limit and available resources; using appropriate minimum voltage as established by the project, and line losses
- Interface temperatures, gradients, and heat flows are within project requirements
- Demonstration of *heat transport capability* and *controllability setpoint range* for two-phase flow systems, such as LHP and CPL, in worst case environments. Controllability over the entire setpoint control range must be demonstrated over the expected range of margined hot and cold environments (+/-30% over the hot and cold mission environments), including appropriate dissipative loads on these systems.

#### 2.6.4.2 Test Parameters

Thermal balance testing is primarily influenced by accurately determining and simulating the appropriate hot and cold mission thermal environments, accurate power measurements, stabilization at plateaus, and accurate modeling of the test article configuration, including the non-flight fixtures, thermal targets, etc.

##### 2.6.4.2.1 Environment Simulation (TB)

As noted in paragraph 2.6.2.5, the same test set-up and thermal/optical targets determined for thermal balance testing is usually desirable for thermal vacuum testing, although additional thermal targets or heating methods may be used to fully achieve test goals at subsystem or system level.

<sup>3</sup> Spacecraft Thermal Control Handbook: Fundamental Technologies (Vol 2), Chapter 19 (Aerospace Corp)

<sup>4</sup> Cryogenic Design Margin – proposed GOLD Rule (Code 552)

Thermal subsystem verification is demonstrated during thermal balance testing, so the thermal environments used must closely simulate the expected worst hot and cold case mission environments used in the project analysis. A typical mission may have very different thermal environments surrounding the satellite that may change drastically through an orbit due to eclipse or other effects, or throughout the mission due to varying beta angles, distance from the sun, etc. But, since temperature stability is critical for thermal balance testing, environmental simulation must be steady state using the orbit average, or maximum/minimum environments as appropriate, and determined by the thermal engineer. Careful consideration of designing test thermal targets to correctly simulate these environments around the test article is key to a successful thermal balance test. Further, since these same targets are typically used to demonstrate system performance beyond the maximum allowable mission temperatures, their design must be even more flexible, and detailed pre-test analysis using the intended target configuration and environmental simulation will be key to the success of the test. This analysis must compare mission predicts to those from the corresponding simulated test cases, in order to validate the thermal balance test set-up. Similarly, an assessment of the test temperatures predicted for the hot and cold cycle plateaus to the various temperature goal of the hardware, will validate the test capability to achieve the desired test levels.

The type of simulation to be used is generally determined by the size of the chamber, the methods available to simulate environmental conditions, and the payload. Generally, the project test engineer should try to achieve the highest practical order of simulation; that is, the one that requires the minimum number of assumptions and calculations to bound the flight worst case thermal environment. The closer the simulation is to the spectrum, intensity and the worst case environments, the less reliance on the thermal analytical model to verify the adequacy of the thermal design. An assessment and accounting of the effects of shadowing, blockage, and/or reflections (both diffuse and specular) in the flight and test configurations, is needed for an accurate simulation, and to ensure they do not adversely affect the simulation. Methods of simulation and the major assumptions for a successful test are described below:

#### 2.6.4.2.2 Internal Power

Through the design phase of a project, thermal analyses typically use the estimated unit dissipations, as provided by the systems engineer or the hardware provider/designer, applying margins to bound the hot & cold analysis cases. These unit power levels should be confirmed through measurements, to the maximum extent practical, at subsystem and system level tests, to ensure model correlation accuracy.

Power dissipation of individual components should be measured to an accuracy of 1% at voltage and temperature extremes during (component) testing. For voltage converters, where efficiency usually varies as a function of power load, sufficient measurement resolution must be provided to accurately determine the converter load and efficiency.

Based primarily on measurements during unit level testing, thermal analysis at higher levels of assembly must use these measured powers to be more accurate, using different operating modes if applicable, for discerning between bounding hot and cold analysis cases. At subsystem/instrument and system/satellite level, systems engineering should provide (1) details on what can be directly measured using flight or test current/voltage monitors, (2) how this information, in conjunction with component/subassembly test data, will be used to determine individual component dissipations during these higher level tests, and (3) a plan to resolve discrepancies during test. Testing at these higher levels should also verify internal power dissipations and line losses, if possible, in all expected flight operational scenarios.

#### 2.6.4.2.3 Test Article Configuration

While the goal is for the test article to be as “flight-like” configuration as possible, at the subsystem/system level there may be some exceptions to this, as discussed in Section 2.6.2.3. Care must be taken to accurately model any difference between the flight and test configurations, including the test chamber and thermal targets in the analytical model.

#### 2.6.4.2.4 Thermal Analysis

Check the GSFC Technical Standards Program website at <http://standards.gsfc.nasa.gov> or contact the Executive Secretary for the GSFC Technical Standards Program to verify that this is the correct version prior to use.

Throughout a project's life cycle, thermal analytical models are developed for the various flight elements, and matured through the development process, culminating with the integration of each element model into a system level model by the system hardware integration entity to be able to predict thermal performance during the mission. Element and integrated system models are used to predict thermal performance in the respective thermal vacuum and thermal balance tests, and data from each thermal balance tests is used to adjust the respective pre-test thermal models to closely match the recorded test data during the model correlation process. The correlation process and criteria are summarized in Section 2.6.4.4, and discussed in detail in GSFC Thermal Branch guideline documentation.

#### 2.6.4.2.5 Stabilization at Thermal Balance Plateaus

Temperature stability is critical in assessing the performance of the thermal control subsystem in the simulated environments, and in ensuring the correct data is used for thermal model correlation. Thus, the thermal stability requirement for thermal balance testing is more stringent than it is for thermal vacuum cycle testing. The various parts of the test article will stabilize at different rates, depending on their thermal time constant that is a function of thermal capacitance and heat flows.

As the test thermal models are developed leading up to PER, analytically determined values can be completed to validate this criteria. These models are initially used to provide steady state predictions, but to ensure validity of the data they also must be used to transiently assess stabilization of the various parts of the test hardware leading to PER, and to establish the various temperature stabilization criteria and validate the test timeline.

There are different approaches to determining a stabilization criteria, but 545/Thermal Branch guidelines are to use more stringent overall requirement, or to tailor the stability criteria on a more discrete, thermal zone basis.

Prior to detailed analysis of these test transitions and stability, a reasonable *overall* criteria of  $<0.1^{\circ}\text{C}/\text{hour}$  (for 4 consecutive hours) for all temperature sensors may be used, to establish preliminary test timelines. Overall criteria:  $<0.1^{\circ}\text{C}/\text{hour}$  (and continuously decreasing for 4 consecutive hours) for all temperature sensors. Or, on a more discrete, thermal zone basis:

$$\Delta Q_i = (MC_P)_i (\Delta T/\Delta t)_i$$

Where:

$\Delta Q_i$  = change in energy (% of dissipation load, W) for each thermally discrete zone (i)

$MC_P$  = Thermal mass (mass \* specific heat, Joules/ $^{\circ}\text{C}$ )

$\Delta T/\Delta t$  = Stabilization rate ( $^{\circ}\text{C}/\text{min}$ ) The typical energy change ( $\Delta Q_i$ ) for thermal balance stabilization is 3% of total  $Q_i$  for the zone; this should be applied to the overall test article, and also discretely to thermally segregated zones or hardware within the test article.

For zones or hardware with no dissipative heat loads, final stabilized equilibrium temperatures should be continuously estimated during the transitions, and there are different methods to do this, they are not repeated here.

For thermal zones cycling on thermostatic heaters, the above criterion is not applicable, but verification of the repeatability of the heater duty cycle is important. A heater can be considered "stabilized" if the heater duty cycle is repeatable within 5% over 3 successive cycles, by comparing ON/OFF cycle durations. If heaters interfere with each other such that a clear, repeatable duty cycle does not occur or if a non-cycling heater control is used, then engineering judgment must be used to assess whether the thermal zone has achieved equilibrium.

Once criteria are established, assessing stabilization during the test using real time temperature data is key to ensure the test is run efficiently, while collecting accurate thermal balance data. Thermal branch guidelines provide information on achieving this.

Check the GSFC Technical Standards Program website at <http://standards.gsfc.nasa.gov> or contact the Executive Secretary for the GSFC Technical Standards Program to verify that this is the correct version prior to use.

### 2.6.4.3 Demonstration

During the bounding hot and cold thermal balance plateaus, the thermal design is demonstrated to maintain all temperatures within the allowable temperature ranges, including margins, giving confidence the flight hardware will be within the same ranges throughout the mission. All primary and redundant thermal hardware is exercised, and active heat transport devices should be exercised over their *planned operating range*.

For actively controlled two-phase systems, design margin is demonstrated by increasing and decreasing the simulated worst case mission environment (external heat loads) by at least 30 %. Demonstration that the active temperature control hardware maintains set-point control under these stressed conditions provides the required design margin. The goal of this testing is to create a load or an environmental condition in excess of what the system will see on-orbit in order to stress the system and demonstrate its overall flightworthiness.

### 2.6.4.4 Special Tests

Many projects add special tests at the end of the hot or cold balance plateaus, or both. Depending on the mission, project requirements, and pre-test predicted margins, examples of special tests may include:

- Infrequent extended eclipses, survival or stability, etc
- Transfers from launch vehicle to ISS where heater power may not be available
- Stability during slew maneuvers
- Thruster catalyst bed heat-up
- Battery charge/discharge cycles
- Alignment tests/measurements to measure/verify STOP models
- *Design control range* for active thermal two-phase heat transport systems with selectable temperature set-points, such as LHPs.

For radiators using embedded two-phase heat transport hardware, such as constant or variable conductance heat pipes, or Loop Heat Pipes, it is critical that infrared imaging be used to verify uniform and consistent heat paths from and between the embedded hardware, including images of both facesheets taken without perturbing the test heat load or physical configuration. Optimally, this test is done before shipment from the vendor, but can be completed after receipt or fabrication of the radiators, such as during incoming inspection. This imaging for instrument or satellite hardware, as appropriate for the hardware institution, follows mechanical environments to verify bond integrity and thermal performance is maintained, prior to thermal vacuum testing.

### 2.6.4.5 Acceptance Requirements

Acceptance requirements for thermal balance testing, at any level, include:

- successful demonstration of thermal subsystem performance in the bounding hot and cold simulated mission environments including operational and survival modes, meeting all design requirements.
- successful correlation of the test article thermal model, as discussed below, for all balance cases.

Demonstration of thermal subsystem performance: The test setup must accurately simulate the selected hot and cold mission environments, so that the thermal control performance can be correctly demonstrated. Simulated thermal balance test environments achieved must match expected flight thermal environments (those used in the analysis cases during the development cycle) within 10% (TBR). In these cases, all temperatures must be maintained within appropriate allowable ranges, per project documentation, with required design/analytical uncertainty applied. All heater circuits must demonstrate duty cycles meet design requirements documented in branch guidelines.

Check the GSFC Technical Standards Program website at <http://standards.gsfc.nasa.gov> or contact the Executive Secretary for the GSFC Technical Standards Program to verify that this is the correct version prior to use.

Thermal Model Correlation: Thermal model correlation is the process where adjustments are made to the thermal model to achieve better agreement with thermal balance test data. The purpose of the correlation is to improve and quantify the accuracy of the thermal model using test data, thus increasing confidence that the thermal model will accurately predict temperatures and heater power for the mission. Test data consist of temperatures, heater power, heater duty cycle, and any boundary conditions (bus voltage, environmental flux data, chamber wall, plate temperatures, etc.) recorded when the thermal balance stability criteria were satisfied for each thermal balance test phase.

The inability of the thermal model to accurately match the test data, typically indicates a deficiency in the model, test setup, or test article hardware. Details of the correlation process are documented in Thermal Branch guidelines, and the model is considered accurate if the correlation goals are met. GSFC recommends a statistical approach, using the success criteria below. Once the correlation is completed, the correlated test thermal model is reconfigured into the flight configuration, and then used to generate final temperature predictions for the various mission phases.

As a goal, the thermal model should correlate to the test data closely, using the difference between the model test temperature predictions and test temperature data (the “errors”) as a means to validate the thermal model for use in flight analysis, and the following correlation criteria:

- Average Deviation of the Errors ( $\Delta T_{AVG}$ ):  $< \pm 1.0^{\circ}\text{C}$  ( $\Delta T = T_{MODEL} - T_{DATA}$ )
- Standard Deviation ( $\sigma$ ) of the Errors:  $< 2.5^{\circ}\text{C}$

Errors  $> 5^{\circ}\text{C}$  must be justified as to why that is acceptable, considering the same predictive error for flight.

- Heater power predictions duty cycles must match thermal balance data within 5%, for all operational and survival heater circuits

Details of the correlation process, per Thermal Branch guidelines and vetted through the engineering peer review process, must be documented and retained along with the final mission models, as part of the project configuration management system through the mission lifetime.

Differences from pre-test predictions  $> 3^{\circ}\text{C}$  must be assessed during the correlation process, and design margins re-assessed as needed.

### 2.6.5 CONTAMINATION VERIFICATION

Project contamination requirements are described in Section 2.8; this section deals with preventing contamination during thermal vacuum testing, since elements of a test item can be sensitive to contamination arising from test operations or from the test item itself. If the test item contains sensitive elements, the test chamber and all test support equipment is examined and certified prior to placement of the item in the chamber to ensure that it is not a significant source of contamination. Particular care is taken to prevent potential contaminants emanating from the test item are not masked by contaminants from the chamber or the test equipment. Chamber bakeout and certification may be necessary for contamination sensitive hardware.

The level of contamination present during thermal vacuum testing is to be monitored using, as a minimum, a Temperature-controlled Quartz Crystal Microbalance (TQCM) to measure the accretion rate and a cold finger to obtain a measure of the content and relative amount of the contamination. The use of additional contamination monitors such as a Residual Gas Analyzer (RGA), Gas Chromatographs/Mass Spectrometers (GC/MS), Fourier Transform Infrared Spectrometers (FTIS), Cryogenic QCM's, mirrors, and chamber wipes can also be considered. When using TQCMs, RGAs, or mirrors, the locations of the sensors must be carefully selected so that they will adequately measure outgassing from the desired source.

Transitions from cold to hot conditions increase contamination hazards because material that has accreted on the chamber walls may evaporate and deposit on the relatively cool test item. Transitions are to be conducted at rates sufficiently slow to prevent that from occurring. It is recommended that testing start with a hot soak and end with a hot soak to minimize this risk. However, if it is necessary that the last exposure

Check the GSFC Technical Standards Program website at <http://standards.gsfc.nasa.gov> or contact the Executive Secretary for the GSFC Technical Standards Program to verify that this is the correct version prior to use.

be a cold one, the test procedure includes a phase to warm the test item before the chamber is returned to ambient conditions so that the item will remain the warmest in the test chamber, thus decreasing the likelihood of its contamination during the critical period. In all cases, every effort should be made to keep the test article warmer than its surroundings during testing.

Check the GSFC Technical Standards Program website at <http://standards.gsfc.nasa.gov> or contact the Executive Secretary for the GSFC Technical Standards Program to verify that this is the correct version prior to use.

### 2.6.5.1 Temperature-Humidity Verification

	Temperature-Humidity	Applicability	Demonstration
Crewed Spaces	If the environment is such that condensation can occur, as shown by analysis, tests must be conducted to demonstrate that the hardware can function under the severest conditions that credibly can be expected.	The test applies to payloads that are to be located in crewed spaces and to equipment placed in crewed spaces for the control or support of payloads located in unpressurized areas.	The hardware must be tested at temperature and relative humidity conditions at least 10°C and 10% RH beyond the limits expected during the mission. The upper humidity conditions, however, should not exceed 95% RH unless condensation can occur during the mission; in that event, tests must be conducted to demonstrate that the hardware can function properly after (or, if applicable, during) such exposure. Temperature cycling, duration, performance tests, and other requirements (except those related to vacuum as described in 2.6.2.4) must apply.
Descent and Landing	Hardware that is to undergo a specified temperature and humidity environment during a re-entry and that must survive this re-entry with a specified performance capability (e.g. throughput or reflectivity) must be subjected to a temperature-humidity test to verify that it can survive the environmental conditions during descent and landing without experiencing unacceptable degradation.	If the test would make the hardware un-flightworthy, such as by rendering thermal control surfaces ineffective, then it should not be performed on the flight item. Instead, an analysis based on tests of engineering or prototype models, or other convincing methods, may be used.	The test item must be placed in a temperature-humidity chamber and a functional performance test must be performed before the item is exposed to the test environment. If a functional performance test was conducted as part of the post-test checkout of the preceding test, those results may be sufficient. The temperature and humidity profiles in Figure 2.6-3 set the parameters for the demonstration. The payload must be in a configuration appropriate for the descent and landing phase. Electrical function tests (2.3) must be conducted after the test exposure to determine whether acceptable limits of degradation have been exceeded.

Check the GSFC Technical Standards Program website at <http://standards.gsfc.nasa.gov> or contact the Executive Secretary for the GSFC Technical Standards Program to verify that this is the correct version prior to use.

	Temperature-Humidity	Applicability	Demonstration
Transportation and Storage	<p>Hardware that will not be maintained in a temperature-humidity environment that is controlled within acceptable limits during transportation and storage must be subjected to a temperature-humidity test to verify satisfactory performance after (and, if applicable, during) exposure to that environment.</p>	<p>The test applies to all payload equipment. It need not be conducted on equipment for which the demonstrated acceptable limits have been established during other portions of the verification program.</p>	<p>The demonstration must be performed prior to the thermal-vacuum test. An analysis must be made to establish the uncontrolled temperature and humidity limits to which the item will be exposed from the time of its integration at the component level through launch. The item must be placed in a temperature-humidity chamber and electrical function tests (2.3) must be conducted before the item is exposed to the test environment.</p> <p>If an electrical function test was conducted during the post-test checkout of the preceding test, the results of that may suffice. Functional tests must also be conducted during the test exposure if the item will be required to operate during the periods of uncontrolled environment.</p> <p>The test must include exposure of the hardware to the extremes of temperatures and humidity as follows: 10°C and 10 RH (but not greater than 95% RH) higher and lower than those predicted for the transportation and storage environments. The test item must be exposed to each extreme for a period of six (6) hours. Electrical function tests must be conducted after the test exposure to demonstrate acceptable performance.</p>

Check the GSFC Technical Standards Program website at <http://standards.gsfc.nasa.gov> or contact the Executive Secretary for the GSFC Technical Standards Program to verify that this is the correct version prior to use.

## 2.6.6 LEAKAGE (INTEGRITY) VERIFICATION

Tests are conducted on sealed items to determine whether leakage exceeds the rate prescribed for the mission.

### 2.6.6.1 Levels of Assembly

Tests may be conducted on the component level of assembly to gain assurance that the item will function satisfactorily before tests are made at higher levels. Checks at the payload level need include only those items that have not demonstrated satisfactory performance at the lower level, are not fully assembled until the higher levels of integration, or the integrity of which is suspect.

### 2.6.6.2 Demonstration

Leakage rates are checked before and after stress-inducing portions of the verification program. The final check may be conducted during the final thermal-vacuum test.

A mass spectrometer may be used to detect flow out of or into a sealed item.

If dynamic seals are used, the item is operated during the test, otherwise operation is not required. The test should be conducted under steady-state conditions, i.e., stable pumping, pressures, temperatures, etc. If time constraints do not permit the imposition of such conditions, a special test method is devised.

### 2.6.6.3 Acceptance Requirements

The above provisions apply to the acceptance testing of previously qualified hardware.

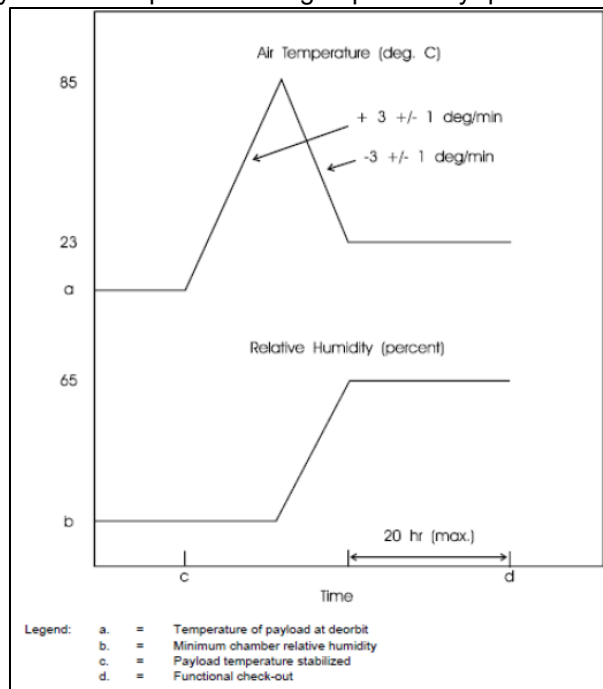

**Figure 2.6-3 Temperature-Humidity Profile for the Descent and Landing Demonstration**

Check the GSFC Technical Standards Program website at <http://standards.gsfc.nasa.gov> or contact the Executive Secretary for the GSFC Technical Standards Program to verify that this is the correct version prior to use.

## SECTION 2.7

### CRYOGENICS & FLUIDS

## 2.7 Cryogenic Philosophy

At Goddard Space Flight Center, Cryogenic engineering activities are defined as applicable to systems operating below 120K. For systems that are above 120K (with exception of cryocooler systems), please reference Section 2.6 on Thermal Engineering. In the special case of cryocoolers, if the cooling load temperature of the cryocooler system is operating at 200K or below, the constructs put forth in this section also apply.

Most unit level testing for design and workmanship verification includes temperature cycling between high and low temperature values. The temperature cycles thermally stress the unit being tested. Since most cryogenic systems cool down from room temperature to an operational temperature below 120K, the classical interpretation of high and low values for cycling is ill-applied. When testing a system that is cooled from room temperature to an operational value below 120K, upon return to room temperature, the cool down and return to ambient cycle should be considered as an actual temperature cycle. For temperature cycling to low side values above 120K, or high side values above room temperature, please reference Section 2.6 on Thermal Engineering.

### 2.7.1 CRYOGENIC SYSTEMS VACUUM AND THERMAL VERIFICATION REQUIREMENTS

The vacuum, thermal, and electrical requirements herein apply to ELV payloads. An appropriate set of tests and analyses shall be selected to demonstrate the following payload or payload equipment capabilities.

- a. The payload shall perform satisfactorily (at low temperature) within the vacuum and Cryo-Thermal mission limits.
- b. The Cryo-Thermal design and the Cryogenic TCS (Thermal Control System) shall maintain the temperature controlled hardware within the established temperature limits during planned mission phases, including survival/safe-hold, if applicable.
- c. The quality of workmanship and hardware materials used shall be sufficient to pass performance testing and thermal cycle test screening (when appropriate) in vacuum, or under ambient pressure.

### 2.7.2 Summary of Requirements

Table 2.7-1 summarizes the tests and analyses that collectively fulfill the general requirements of Section 2.7. Tests noted in the table may require supporting analyses. The order in which tests and/or analyses are conducted should be determined by the project in conjunction with the cognizant cryogenics engineer and set down in the environmental verification plan, specification, and procedures (2.1.1.1.1 and 2.1.1.4). Mechanical testing should occur prior to Cryo-thermal testing at the systems level

The Cryo-thermal cycling requirements highlighted in paragraph 2.7.3.4 apply to most cryogenic systems in general. However, the convention of thermally stressing a cryogenic unit via additional heat load does not apply to "room temperature" electronics used to operate cryogenic systems/components. These items must be qualified for proper thermal performance in a flight-like vacuum environment. Qualification and acceptance thermal-

Check the GSFC Technical Standards Program website at <http://standards.gsfc.nasa.gov> or contact the Executive Secretary for the GSFC Technical Standards Program to verify that this is the correct version prior to use.

vacuum verification programs at temperature regimes above 120K tend to use temperature as a basis for margin. For details on how to apply temperature margin within this temperature regime, please reference section 2.6.2.4.a.

The thermal cycle fatigue life test requirements of 2.4.2.1 also applies to electronics used to control parts of the cryogenic system, as well as parts of cryogenic hardware that may be susceptible to thermally induced mechanical fatigue.

### 2.7.3 Cryo-Thermal-Vacuum Qualification

The Cryo-thermal vacuum qualification program should ensure that the payload operates satisfactorily in a simulated space environment at thermal loading conditions with margin added. The effective thermal loading conditions will be in excess of that expected during the actual mission. The percent excess thermal loading will be a function of the stage in the systems life cycle that the project is at during the test.

Table 2.7-1  
Cryogenic Vacuum, Thermal, Electrical and Mechanical Requirements

Requirement	Payload or Highest Practicable Level of Assembly	Subsystem including Instruments	Unit/ Component
Thermal-Vacuum <sup>1,5</sup>	T	T	T <sup>2</sup>
Thermal Balance <sup>1,3,5</sup>	T and A	T,A	T,A
Temperature-Pressure-Humidity <sup>3</sup> (Habitable Volumes)	T/A	T/A	T/A
Temperature-Humidity <sup>4</sup> (Transportation & Storage)	A	A	A
Cold Vibration Testing <sup>6</sup>	T	T	T
Leak Testing <sup>7</sup>	T	T	T

1. Applies to hardware carried in unpressurized spaces and to ELV-launched hardware.
2. Temperature cycling at ambient pressure may be substituted for thermal-vacuum temperature cycling of cryogenic system warm components (i.e., components that operate at or near room temperature) if it can be shown as acceptable via analysis. Temperature levels and gradients predicted via thermal analysis must be as severe in air as when tested under vacuum conditions.
3. Applies to flight hardware located in pressurized environments.
4. Consideration should be given to environmental control of the enclosure.

Check the GSFC Technical Standards Program website at <http://standards.gsfc.nasa.gov> or contact the Executive Secretary for the GSFC Technical Standards Program to verify that this is the correct version prior to use.

5. Survival/Safehold testing is performed on equipment which may experience (non-operating) temperature extremes more severe than when operating. The equipment tested is not expected to operate properly within specifications until the temperatures have returned to qualification temperatures.

6. Projects that include payloads that will launch with critical Cryo-thermal system components at operational temperatures must include cold vibration testing of said components in the environmental test campaign. The equipment is expected to operate properly within specifications at temperature following the cold vibration testing.

7. Hardware that passes this test at the lower assembly levels need not be retested at the higher assembly levels unless there is concern that the structural integrity of the vessel wall has been compromised.

T = Test required.

A = Analysis required; tests may be required to substantiate the analysis.

T/A = Test required if analysis indicates possible condensation.

T, A = Test is not required at this level of assembly if analysis verification is established for non-tested elements.

#### 2.7.3.1 Applicability

All flight hardware must be subjected to thermal-vacuum testing in order to demonstrate satisfactory operation in modes representative of mission functions at the nominal operating temperatures with heat load margin on the extremes predicted for the mission, and during temperature transitions. The tests should demonstrate satisfactory operation over the range of possible flight voltages. In addition, hot and cold turn-on should be demonstrated (as appropriate) for portions of the overall cryogenic system operating at or near room temperature. Exceptions to this standard are applicable for stored cryogen dewar systems tested in ambient with a guard vacuum in the dewar. For details, please reference the cognizant cryogenic engineer on the project.

The Goddard Space Flight Center generally utilizes a protoflight qualification test program. Since the basis of the protoflight qualification test program is to demonstrate the ability to operate under extreme thermal conditions and the cryogenic temperature regime is inherently extreme, temperature based operational and contingency test margins are ill-applied to cold segments of the cryogenic system. For warm segments of the cryogenic system please reference section 2.6.2.1 for temperature and contingency margins.

Spare components must undergo a test program in which the demonstration and/or performance requirements at temperature should be the same as that which other flight components are subjected to at the component, subsystem, and payload levels of assembly. As a minimum, spare components should be subjected to eight cold cycles prior to integration onto the payload/spacecraft.

Check the GSFC Technical Standards Program website at <http://standards.gsfc.nasa.gov> or contact the Executive Secretary for the GSFC Technical Standards Program to verify that this is the correct version prior to use.

Redundant components should be exercised sufficiently during the test program to verify proper orbital operations. Testing to validate all applicable operational modes should be performed. The method of conducting the tests should be described in the environmental verification test specification and procedures (2.1.1.1.1 and 2.1.1.4).

For spare and redundant components, the test temperature levels and heat load margin demonstrated should be the same as those for flight components.

For repaired equipment, usually a component, subsequent testing must be sufficient to demonstrate flight worthiness. If additional testing is expected at either the Subsystem or the Payload level, the standards for flight worthiness should be the same as for new equipment. For portions of the cryogenic system operating near room temperature, please reference Section 2.6.2.4.b for the satisfactory number of temperature cycles.

Thermal balance verification at cryogenic temperatures is typically performed as part of the thermal-vacuum test program. The approach used should be described in the environmental verification specification and procedures.

#### 2.7.3.2 Special Considerations

- a. Unrealistic Failure Modes - Care should be taken during the test to prevent unrealistic environmental conditions that could induce test failure modes. For instance, maximum rates of temperature change should not exceed acceptable limits. The limits are based on hardware characteristics or orbital predictions.
- b. Avoiding Contamination - Elements of a test item can be sensitive to contamination arising from test operations or from the test item itself. If the test item contains sensitive elements, the dewar (and/or test chamber) and all test support equipment should be examined and certified prior to placement of the item in the chamber to ensure that it is not a significant source of contamination. Particular care should be taken that potential contaminants emanating from the test item are not masked by contaminants from the chamber or the test equipment. Chamber bakeout and certification may be necessary for contamination sensitive hardware.
- c. Vibration – At low temperatures, vibrational loading of cryogenic volumes can result in thermal heating. This phenomena is especially of concern when dealing with Sub-Kelvin cooling systems where the associated thermal loading can impact the operational temperature of the item being cooled. Care should be taken during ground testing to minimize the propagation of vibrational loading into the cryogenic volume undergoing testing.
- d. Magnetic Fields – When working with Sub-Kelvin ADR (Adiabatic Demagnetization Refrigeration) systems, care should be taken to insure that magnetic fields present on the platform are not substantial enough to penetrate the ADR magnetic shielding and affect the cooling performance of the ADR system.
- e. Cold Surfaces - Transitions from cold to hot conditions increase contamination hazards because material that has accreted on the chamber walls may deposit on cold surfaces. Transitions must be conducted at rates sufficiently slow to prevent that from occurring.

Check the GSFC Technical Standards Program website at <http://standards.gsfc.nasa.gov> or contact the Executive Secretary for the GSFC Technical Standards Program to verify that this is the correct version prior to use.

The test procedure should include a warm-up phase that allows the test item to warm up to ambient prior to vacuum conditions in the chamber being broken. This will effectively decrease the likelihood of its contaminants collecting on test articles.

- f. Card Level Analyses Verification – For requirements pertaining to card level verification, please reference section 2.6.2.2.c.
- g. EEE Parts – Selection of EEE parts and/or assemblies for use either in or with Cryogenic Cooling systems will be at the discretion of the cognizant Cryogenics Engineer w/concurrence and screening support provided by Code 560. In the event that EEE parts and/or assemblies are acquired as part of a procurement (e.g., Cryocooler electronics, ADR electronics, electromechanical plumbing valves, etc.) then the cognizant Cryogenics engineer and the Code 560 project representative will work with the vendor to ensure screening requirements are adhered to.
- h. Test Temperature Sensor Location - Test temperatures for a cryogenic thermal vacuum, Dewar or cryostat test should be based on the temperatures at designated locations (e.g. inner vessel wall, shield, etc.). The locations should be selected in accordance with an assessment to ensure that components or critical parts of the cryogenic system achieve the desired temperature for the required time during testing. The temperature sensors should be attached either on the component of interest or within close proximity to a physical location with a predetermined temperature requirement. For additional information on the “control” temperature criterion to be used, contact the cryogenic engineer supporting the Project or the Cryogenics and Fluids Branch.

#### 2.7.3.3 Level of Testing

There is a minimum of three levels of testing; the component, subsystem/instrument, and the payload/ spacecraft level. In cases where testing is compromised as demonstrated by an inability to achieve operational cryogenic temperatures within the full-up assembly, testing at lower levels of assembly may be warranted. Component level testing may require vacuum and/or hermetic seal pressure tests (e.g., heat switch shells, ADR salt pills, cryocooler fluid loop, etc.). In addition, thermophysical properties and Cryo-mechanical strength tests at cryogenic temperatures may be required for construction materials that are not well characterized. Please reference Code 552 or the project’s cryogenics engineer for determination of such.

#### 2.7.3.4 Test Parameters

Cryo-Thermal margins, operational temperatures, temperature cycling, hold time at temperature, superconducting current loads, test chamber conditions, transition rates, temperature and pressure regimes are key parameters that define the environmental conditions associated with environmental testing:

- a. Workmanship Margins – Heat Load margins should be established to induce thermal stress conditions to detect unsatisfactory performance that would not otherwise be uncovered before flight. The workmanship test margin is defined as an increase in a condition beyond the range of conditions the hardware would experience over the projected lifetime. This could include temperature, heat loads, current applied, static and vibrational loads, magnetic field penetrations and/or environmental conditions.

Check the GSFC Technical Standards Program website at <http://standards.gsfc.nasa.gov> or contact the Executive Secretary for the GSFC Technical Standards Program to verify that this is the correct version prior to use.

The minimum temperature to be imposed during unit level thermal vacuum testing should represent, as indicated above, a temperature low enough, to induce stress during cool down, followed by operation. The basis for the test temperature should be established using unit temperature requirements. For instrument/subsystem and spacecraft level testing, the operational temperatures imposed should be derived from the collection of various unit temperature ranges. For multiple instrument/spacecraft builds where a correlated model is developed on the first build, subsequent builds may base the thermal vacuum test temperatures on predicted temperatures derived analytically using the test verified model, only if these builds are identical in configuration. When a thermal balance test precedes the thermal vacuum test, results from that test may be used to refine the thermal vacuum test criteria, presuming there is sufficient time to correlate the model and generate updated predictions prior to the thermal vacuum test. If predictions from a verified model are not available at the time of the thermal vacuum test, the basis for the operational temperature tested to should be established by the Project Office (w/consultation from the cognizant Cryogenics Engineer). This basis should constitute the “flight” operational temperature tested to.

For passively controlled systems, a qualification heat load margin should be applied to the “flight” minimum operating temperature. The margin for acceptance testing of previously qualified hardware may be reduced depending on the phase of the life cycle, as long as testing to these levels does not preclude protoflight test levels from being achieved at higher levels of assembly.

Test margins for actively controlled hardware, as specified in the following three paragraphs, should apply to both qualification/protoflight and to acceptance testing of said systems and components. (For the purposes of this document, the following are considered to be actively controlled cryogenic hardware: Cryocoolers, ADR (Adiabatic Demagnetization Refrigerators), Stored Cryogen Dewar Systems (i.e., stored Cryo-materials in either liquid or solid phase), Cryogenic circulation loops, Vapor Cooled Shields for Dewars/Cryostats, Cryocooler-cooled Shields and TVS (Thermodynamic Vent Systems).)

For actively controlled systems such as Heaters, Thermoelectric Coolers (TECs), Cryocoolers and ADRs, a test thermal margin must be imposed on a setpoint that is under control based on the phase of the life cycle at the time of test. The margin used shall be borrowed from the Cryo-Thermal design guidelines listed in Table 2.7-2. The required range of thermal control at temperature shall be demonstrated in the “flight” operational thermal environment during thermal balance testing.

Table 2.7-2  
Margin as a function of Phase In Project Life Cycle

Life Cycle Phase	Heat Load Margin (%)
Pre-Phase A	100
Phase A	100
Phase B	80
Phase C	50
Phase D	40
Phase E	33

Check the GSFC Technical Standards Program website at <http://standards.gsfc.nasa.gov> or contact the Executive Secretary for the GSFC Technical Standards Program to verify that this is the correct version prior to use.

For a component/subsystem/payload with an active control system, thermal stressing of the cooling system at temperature should be induced by the increase of a heat load which simulates heat leak into the system. The active temperature control hardware must maintain control under these stressed conditions. The goal of this testing is to create an environmental condition in excess of what the system will see on-orbit in order to stress the system and demonstrate its overall flightworthiness.

Margins based on high/low temperatures are not applicable to all portions of cryogenic systems operating within the cryogenic temperature regime. Alternatively, heat load margins on Cryogenic systems should be established by the Cryogenics engineer and the Project based on the unique characteristics of the test article.

The survival/safehold thermal-vacuum tests should consist of driving the unit, without any thermal margin, to the desired temperature, and then returning that unit to the operational temperature, if different, to functionally check the operation. No component should be allowed to exceed the non-operating temperature limit with allowable tolerances.

For testing at higher levels of assembly, the “not-to-exceed” temperatures should be established based on temperatures actually achieved during testing at lower levels of assembly.

- b. Temperature Cycling of Cryogenic systems - Temperature cycling for purposes of inducing thermal stresses in cryogenic systems is only applicable to portions of the cryogenic TCS that operate above 120K (e.g., Cryocooler, ADR or valve/manifold control electronics). Cycling during ground testing may also be preclusive due to time constraints and may cause undue stress on flight systems. The number of cycles should be determined by the project with the consultation of the project’s cognizant Cryogenics Engineer. For rules and guidelines pertaining to temperature cycling of items above 120K, please reference section 2.6.3.2.2.2.
- c. Duration - The total test duration must be sufficient to demonstrate performance and uncover early failures. The duration varies with the time spent in flight at the temperature levels and with such factors as the number of mission-critical operating modes, the test item thermal inertia, and test facility characteristics. Minimum temperature dwell times are as follows:
  1. Payloads/Spacecraft - Payloads must be exposed for a minimum of one hundred fifty (150) hours at operating temperature. The thermal soak at operating temperature must be of sufficient duration to allow time for the required performance tests (functional, comprehensive, etc.) for all modes of operations including safehold/survival. Projects seeking to reduce the durations of time at temperature must submit deviations and receive approval from ETD prior to PDR.
  2. Subsystem/Instrument - Subsystems and instruments must be exposed for a minimum of one hundred fifty (150) hours at operating temperature. The thermal soak at temperature must be of sufficient duration to allow time for the required performance tests for all modes of operation including safehold/survival.

Check the GSFC Technical Standards Program website at <http://standards.gsfc.nasa.gov> or contact the Executive Secretary for the GSFC Technical Standards Program to verify that this is the correct version prior to use.

3. Unit/Component - Components must be exposed for a minimum of one hundred fifty (150) hours at operating temperature. The thermal soak at operating temperature must be of sufficient duration to allow time for the required performance tests for all modes of operation. Turn-on demonstrations should be performed at temperature. If temperature cycling is occurring for warm segments of the cryogenic thermal control system, please reference section 2.6.2.4.c.

The survival/safehold TV test should consist of soaking the non-operating element for at least four (4) hours at operating temperature conditions.

- d. Pressure - The chamber pressure after the electrical discharge checks are conducted must be less than  $1.33 \times 10^{-3}$  Pa. ( $1 \times 10^{-5}$  Torr). The ability to function through the voltage breakdown region must be demonstrated if applicable to mission requirements (those elements that are operational during launch).

#### 2.7.3.5 Test Setup

The setup for the test, including any instrument and/or component stimulators, should be reviewed to ensure that the test objectives will be achieved, and that no test induced problems are introduced. The payload test configurations should be as described in the test plan and test procedure. The test item should be, as nearly as practicable, in flight configuration with associated cryogenic GSE as required. Heating and/or cooling on the payload may be required to achieve operational temperatures ranges.

Critical temperatures for warm segments of the cryogenic system should be monitored throughout the test and alarmed if possible. The operational modes of the payload should be monitored in accordance with 2.3. The provisions of 2.3 apply except when modified by the time considerations of 2.7.2.4 d.

#### 2.7.3.6 Demonstration

- a. Electrical Discharge Check - Items that are electrically operational during pressure transitions must undergo an electrical discharge check to ensure that they will not be permanently damaged from electrical discharge during the ascent and early orbital phases of the mission, or during descent and landing (if applicable). The test should include checks for electrical discharge during the corresponding phases of the vacuum chamber operations.
- b. Outgassing Phase - If the test article or system is contamination sensitive (or if required by the contamination control plan) an outgassing phase must be included to permit a large portion of the volatile contaminants to be removed. The outgassing phase will be incorporated into a hot exposure that will occur during thermal-vacuum testing. Please reference section 2.6 for additional details.
- c. Transitions - The test item should remain in an operational mode during the transitions between temperatures so that its functioning can be monitored under a changing environment. The requirement may be suspended when turn-on of the test item is to be

Check the GSFC Technical Standards Program website at <http://standards.gsfc.nasa.gov> or contact the Executive Secretary for the GSFC Technical Standards Program to verify that this is the correct version prior to use.

demonstrated after a particular transition. Caution must be taken not to violate temperature limits, or to induce test failures caused by excessive and/or unrealistic gradients or CTE mismatches. Violation of functional specifications is acceptable during transitions with the approval of the Project Office.

The rate of transition should be specified by the cognizant cryogenics engineer to insure that stresses caused by thermal gradients will not damage the test article. Upon warm-up to ambient temperatures, the temperature gradient between the chamber and the test item should not exceed 20K.

- e. Operational Temperature Conditions - The temperature controls should be adjusted to cause the test item to stabilize at the desired operational temperature. Turn-on capability should be demonstrated at the start of this temperature condition. The duration of the test should be sufficient to permit the performance of the functional tests with a minimum soak time as specified in section 2.7.2.4.c.
- f. Start-Up Demonstrations - Start-up capability should be demonstrated to verify that the test item will turn on after exposure to flight like operational temperatures. Turn-on capability should be demonstrated under vacuum (and/or flight like conditions), at temperature on the primary and redundant side, as applicable. The test turn-on temperature is defined by the expected mission operations with margin. At the Unit/Component level, this demonstration should consist of power-off, power-on cycles for each unit/component. At the Subsystem/Instrument level, and Payload/Spacecraft level, this demonstration should be consistent with the scenario regarding which units/components are actually power cycled (off/on) during flight, and also for recovery from a survival/safe-hold mode in orbit. For example, recovery from cold survival/safehold temperatures to cold operational temperatures may be accomplished by turning the units/components of the test item back on and allowing internal dissipation to warm the item to operational temperatures. Proper operation is then checked after the component has returned to operational temperature levels. The duration of the soak with the test item off, or in survival/safe-hold mode, should be in accordance with section 2.7.2.4.c.
- i. Functional Test - Functional tests should be performed at the low temperature plateau and during transitions. A comprehensive performance test (CPT) should be performed at least once during operational plateau(s) at cryogenic temperatures, exercising complete primary and redundant operations, unless it is determined to be impractical. In that case, with project approval, a limited functional test may be substituted if satisfactory performance is demonstrated for the major mission critical modes of operation. Otherwise, the requirements of section 2.3.2 apply. Functionality of the thermal control system hardware should be demonstrated during the Thermal-Vacuum Qualification test.
- j. Return to Ambient -In general, the temperature gradient between the chamber surroundings and the test item should not exceed 20K during warm-up to ambient conditions in order to protect against contamination from the test facility. Should the project seek to conduct warm-up to ambient with an alternate temperature gradient, concurrence must be obtained from the Cryogenics engineer and the Contamination engineer.

Check the GSFC Technical Standards Program website at <http://standards.gsfc.nasa.gov> or contact the Executive Secretary for the GSFC Technical Standards Program to verify that this is the correct version prior to use.

Before the chamber can be backfilled with air, all sensors should read above the dew point to insure that water does not condense on the payload.

- i. General - Test parameters for cryogenic systems should be based on flight operations. Parameters should be determined early in the program by the Cryogenic Engineer and the Science teams.

#### 2.7.3.7 Special Tests

Special tests may be required to evaluate unique features, such as radiative thermal loading from a surface (temperature ranging 120K to 10K) on a low temperature stage or heat rejection efficiency of a Cryo-radiator with heat load margin applied.

The test configuration shall reflect, as nearly as practicable, the configuration expected in flight.

When items undergoing test include unusual equipment, special care must be exercised to ensure that the equipment does not present a hazard to the test item, the facility, or personnel.

Any special tests shall be included in the environmental verification specification.

#### 2.7.3.8 Failure-Free-Performance

The total number of trouble-free hours for functional operations at temperature will be driven by the period of time required for completion of a single in-flight measurement event while at operational temperatures. The final determination for the hour based requirement is subject to the project with guidance from the cognizant cryogenic engineer. Once established, the requirement must be demonstrated in the Cryo-thermal verification program. Hours of operation will be classified as "failure free" permitting they have been demonstrated under vacuum conditions (Refer to section 2.3.4) as appropriate. This is with exception to stored cryogen Dewar systems tested in ambient with a guard vacuum of  $\leq 10^{-5}$  Torr. Failure free hours of operation for Dewar testing with stored Cryo-materials may consist of a combination of vacuum and ambient testing.

#### 2.7.4 Thermal Balance Qualification

The adequacy of the Cryo-thermal design and the capability of the thermal control system shall be verified under simulated space environmental conditions, as defined by the cryogenics engineer. Consideration should be given for testing an "off-nominal" case such as a safhold or survival mode. The test environments used should envelope flight operational environment thereby promoting validation of the adequacy of the cryogenic temperature control system design. Thermal Balance Test data obtained can be used to correlate and/or validate the thermal model. Correlated thermal models may then be relied upon for temperature prediction under non-tested T-Vac and/or Flight conditions. It is preferable that the thermal balance test precede the thermal vacuum test so that the results of the balance test can be used to establish the temperature goals for the thermal vacuum test.

Thermal design margins must be verified under operational temperature conditions and thermal loads. This standard also extends to safhold and survival conditions. Select examples of the margins to be established are:

Check the GSFC Technical Standards Program website at <http://standards.gsfc.nasa.gov> or contact the Executive Secretary for the GSFC Technical Standards Program to verify that this is the correct version prior to use.

- Operational heater duty cycle less than 70%, including minimum voltage as established by the project;
- Survival heater margin, dependent on survival setpoint/temperature limit and available resources;
- Interface heat flows are within requirements;
- Hold time at temperature for ADR (Adiabatic Demagnetization Refrigeration) and stored Cryogen dewar systems;
- Current load tested with margin against required superconducting current, at temperature, for High Temperature Superconducting leads;
- Radiator heat rejection margin in worst case environments, dependent on available resources.

#### 2.7.4.1 Alternative Methods

It is preferable to conduct a thermal balance test on the fully assembled payload. If that is impracticable, one of the following alternative methods may be used:

Test a thermally similar physical representation of the flight payload (e.g. a physical thermal model) and compare the results with predictions derived from the analytical model (modified as necessary).

If the flight equipment is not used in the tests, additional tests to verify critical thermal properties, such as views to warm surfaces, thermal control coating absorptivity and emissivity, shall be conducted to demonstrate similarity between the item tested and the flight hardware.

#### 2.7.4.2 Use of a Thermal Analytical Model

In the course of a payload program, analytical thermal models are developed for the payload, its elements, and the mission environment for the purpose of predicting the thermal performance during the mission. The models can also be modified to predict the thermal performance in a test-chamber environment. That is, the models are frequently used, with appropriate changes to represent known test chamber configurations, to develop the proper environments for thermal balance test cases and to develop the proper controls for thermal vacuum test levels. Frequently it is not possible to provide a direct, one-to-one test environment to simulate the space environment (e.g., chamber walls are warmer than space, or heaters are used to foster Earth IR and Solar loading), so it is necessary to use the analytical model to establish the appropriate test environments.

Correlation of the results of the chamber thermal balance tests with predictions derived from the modified analytical model provides a means for validating the design, evaluating the as-built temperature control system, and for improving thermal math model accuracy. The verified

Check the GSFC Technical Standards Program website at <http://standards.gsfc.nasa.gov> or contact the Executive Secretary for the GSFC Technical Standards Program to verify that this is the correct version prior to use.

analytical model can then be used to predict response to untested cases as well as generating flight temperature predictions.

#### 2.7.4.3 Method of Cryo-Thermal Simulation

The type of simulation to be used is generally determined by the size of the chamber, the desired operational temperature, the predicted heat leak into the system, the methods available to simulate environmental conditions, and the payload. In planning the method to be used, the test engineer should try to achieve the highest practical order of simulation; that is, the one that requires the minimum number of assumptions and calculations to bound the flight low temperature environment. The closer the simulation is to the spectrum, intensity and the worst case environments, the less reliance there is on the analytical model to verify the adequacy of the cryogenic design. Appropriate consideration should be given to account for the effects of stray light, shadowing, blockage, and/or reflections (both diffuse and specular), as well as emissivity of metals as a function of temperature. In the flight and test configurations they either are needed for an accurate simulation, or are artifacts that could adversely affect the simulation. Methods of simulation and the major assumptions for a successful test are provided below:

a. Solar input/Planetary Input

For details on Solar and Planetary Inputs, please reference section 2.6.3.3.

b. Interfaces – Conductive interface temperatures may be simulated with cold plates that are held at worst-case boundary conditions. Their temperature can be varied for cold flight, hot flight, and safhold conditions or parametrically varied. Thermal performance across interfaces along heat flow path are critical to achieving desired operational temperatures in Cryogenic Systems.

Since the payload must be supported during testing there is generally a non-flight conductive heat flow path that is, in flight, a radiative interface, usually with the space environment (e.g., the launch vehicle attachment interface). As much conductive isolation as possible should be used between the test article and this non-flight conductive interface. A heater is placed on the test fixture side of such a conductive interface and two temperature sensors spanning the interface are used. The heater is controlled until the temperatures of the two sensors are the same, thereby minimizing the heat flow through this path. Without good isolation here, it is likely that an unrealistic and hard to quantify bias will be introduced at this interface, making the test results difficult to assess. Isolation is typically achieved by using fiberglass standoffs. However, the payload may need to be suspended with low conductance cables if the system has a high sensitivity to small heat flows.

c. Radiative Sink Temperature – The overall radiative sink temperature is typically achieved by varying the chamber shroud temperature. Three typical temperature regimes of chambers are (1) Flooded with Liquid Nitrogen, (LN2 approximately 80-90 K), (2) Controlled with Gaseous Nitrogen (GN2 approx. 170-275K), and (3) Gaseous Helium (20-30 K).

Check the GSFC Technical Standards Program website at <http://standards.gsfc.nasa.gov> or contact the Executive Secretary for the GSFC Technical Standards Program to verify that this is the correct version prior to use.

Sink temperatures for individual radiators and critical surfaces are controlled with cryopanel. Cryopanel for cryogenic systems may require special enhancements, for example, open-face honeycomb radiators to increase emittance values. Three typical temperature regimes of cryopanel are (1) GN<sub>2</sub> (approximately 130-275 K), (2) LN<sub>2</sub> (approximately 80-90 K), and (3) GHe (approximately 20-30 K). For temperatures in between these values heaters can be added to the cryopanel or a heater plate that is conductively coupled to the cryopanel can be used.

Test and flight predicts of the energy flow from critical surfaces should be compared. Predictions of both the energy flow and temperatures from the test model should be at least as severe as calculated in the flight model.

- d. Passive Payloads - For passive cooling of cryogenic payloads, chamber walls and/or cryopanel may need to be colder than Liquid Nitrogen temperatures to adequately reject heat. Temperature variations of emissivity should be taken into account in the sink temperature determination analysis.
- e. Dewar Systems – A test dewar may be necessary to simulate the conditions that a payload would see inside a flight dewar. Cooling in a test dewar is available over the temperature range of approximately 0.05 to 120 Kelvin (with gaps). The dewar system may utilize solid cryogen, (e.g., Argon, Nitrogen, Neon or Hydrogen), liquid cryogen (e.g., Neon, Argon, Helium or Nitrogen). During ground testing there is a gravity effect on cryogen that is not seen in flight. Interfaces between the top of the dewar and the payload may be warmer than what would be seen in flight.
- f. Cryocoolers - Cryocoolers are low temperature Cryo-mechanical heat pumps. Standard cryocoolers consist of a compressor, expander device, and heat exchangers on the high pressure side and at the load location. The boundary temperatures for standard cryocoolers are 300K and the load temperature at the heat acquisition location (i.e., a cryogenic temperature). Cryocoolers use gas phase cryogenic fluid as the refrigerant.
- g. Thermal Straps – Thermal Straps are solid state thermal conductors made from either a series of foils or braided wires. They provide a conductive heat flow path across two boundary temperatures. Boundary temperatures driving the heat flow process in these devices can be as low as 100 mK. Thermal Straps are used in applications spanning 100 mK all the way to 300K.
- h. Zero-Q - Certain test-peculiar conductive paths, such as test cables attached to the thermal balance test article, are controlled so that non-flight-like heat does not flow into or out of the test article. During thermal balance the test cabling is minimized. If possible, non-flight GSE should not be present during thermal balance testing. At a minimum, necessary test cables are fabricated to cryogenic standards for reduced parasitic heat leak and are wrapped with multilayer insulation (MLI) to a sufficient distance from the test article.

One method of control is to place a guard heater downstream of two temperature sensors. Control is then applied to the downstream sensor nearest the heater in an effort to match its value with that of the sensor nearest the test article. The heater is controlled until the temperatures of the two sensors are the same, thereby minimizing the heat flow through this path.

Check the GSFC Technical Standards Program website at <http://standards.gsfc.nasa.gov> or contact the Executive Secretary for the GSFC Technical Standards Program to verify that this is the correct version prior to use.

- i. Avoiding Contamination – Refer to section 2.6.2.2.b
- j. Hardware Orientation – Cryogen Storage Tanks, Heat Switches, Heat Pipes, Pulse Tube Cryocoolers and other cryogenics hardware will be affected by component orientation in the 1g environment if improperly aligned with the gravity vector. The plan established for testing should accommodate orientations of the flight hardware that position these devices in a gravity neutral orientation. Hardware levelness or other orientation requirements should be verified in the test chamber, prior to pump down.

#### 2.7.4.4 Internal Power

Power dissipation of individual components should be measured using a four wire technique to resolve both current and voltage independently. Subassembly testing should verify internal power dissipations and line losses, if possible. Prior to spacecraft level testing, the Project should provide: (1) details on what can be directly measured using current/voltage monitors, (2) how this information, in conjunction with component/subassembly test data, will be used to determine individual component dissipations during the spacecraft test, and (3) a plan to resolve discrepancies during test.

#### 2.7.4.5 Special Considerations

Extraneous effects such as gaseous and/or molecular conduction in residual atmosphere should be kept negligible by vacuum conditions in the chamber; pressures below  $1.33 \times 10^{-3}$  Pa ( $1 \times 10^{-5}$  Torr) are usually sufficiently low to mitigate these effects.

#### 2.7.4.6 Demonstration

The number of energy balance conditions simulated during the test must be sufficient to verify the thermal design and analytical model. To verify and correlate the thermal analytical model, a minimum of three test cases is required. It should be noted, however, that the number of variables associated with a thermal analytical model is large compared to the number of thermal balance cases that can be practically included in a test. The verification of the thermal design, whenever possible, should therefore be accomplished by using test environments that bound the low temperature flight environment such that the test results directly validate the adequacy of cryogenic thermal control system design. The duration of the thermal balance test depends on the mission, payload design, payload operating modes, and times to reach stabilization. Ideally, stabilization criteria should be a small percentage of the residual energy in the system versus performance at steady state as predicted either through thermal analysis or extrapolation of an exponential decay function. The stabilization criteria will be dependent upon the operational temperature the Cryogenic cooling system is designed to operate at and will be defined by the project's cognizant cryogenics engineer.

The exposures must be long enough for the payload to reach stabilization so that temperature distributions in the steady-state conditions may be verified. The conditions defining temperature stabilization should be described in the environmental verification specification and should be determined by the Cryogenics Engineer.

Check the GSFC Technical Standards Program website at <http://standards.gsfc.nasa.gov> or contact the Executive Secretary for the GSFC Technical Standards Program to verify that this is the correct version prior to use.

The differences allowed between predicted and measured temperatures are determined by the cognizant Cryogenics Engineer and verification of the thermal analytical model is considered accomplished if the established criteria are met. This criterion should be established prior to the environmental testing.

#### 2.7.4.7 Acceptance Requirements

A thermal balance qualification test is required (based on the nominal operational temperature predicted). A full qualification thermal balance test may be waived by a project only with the consent of the Cryogenics Engineer permitting that sufficient margin is known to exist.

#### 2.7.5 Temperature-Humidity-Oxygen Deficiency Verification

##### 2.7.5.1 Temperature-Humidity: Transportation and Storage

Specialized hardware that requires temperature regulation during storage and transfer (e.g., ADR salt pills or High Temperature Superconducting leads) must not be subject to temperature humidity testing given the components/subsystems are temperature controlled and maintained below well-established temperature limits. Hardware that will not be maintained in a temperature-humidity controlled environment that is maintained within acceptable limits during transportation and storage should be subjected to a temperature-humidity test to verify satisfactory performance after (and, if applicable, during) exposure to that environment.

##### 2.7.5.1.1 Applicability

The test applies to all payload equipment exposed to ambient. It need not be conducted on equipment for which the demonstrated acceptable limits have been established during other portions of the verification program.

##### 2.7.5.1.2 Demonstration

The demonstration should be performed prior to the thermal-vacuum test. An analysis should be made to establish the uncontrolled temperature and humidity limits to which the item will be exposed. The item should be placed in a temperature-humidity chamber and electrical function tests (2.3) should be conducted before the item is exposed to the test environment.

If an electrical function test was conducted during the post-test checkout of the preceding test, the results of that may suffice. Functional tests (where appropriate) should also be conducted during the test exposure if the item will be required to operate during the periods of uncontrolled environment.

The test should be designed to expose the hardware to the extremes of temperatures and humidity predicted for the transportation and storage environments. Exposure to test conditions will be performed for a period of (6) hours. Electrical function tests should be conducted after the test exposure to demonstrate acceptable performance.

Check the GSFC Technical Standards Program website at <http://standards.gsfc.nasa.gov> or contact the Executive Secretary for the GSFC Technical Standards Program to verify that this is the correct version prior to use.

#### 2.7.5.1.3 Acceptance Requirements

The above provisions apply to previously qualified hardware.

#### 2.7.6 Leakage (Integrity Verification)

Tests should be conducted on sealed items to determine whether leakage exceeds the rate prescribed for the successful operation of the cryogenic hardware by the project, with consultation from the Cryogenics Engineer.

##### 2.7.6.1 Levels of Assembly

Tests may be conducted at the component level of assembly to gain assurance that the item will function satisfactorily before tests are made at higher levels. Nonetheless, checks at the payload level will include only those items that have not demonstrated satisfactory performance at the lower level, are not fully assembled until the higher levels of integration, or the integrity of which is suspect.

##### 2.7.6.2 Demonstration

Leakage rates are checked before and after stress-inducing portions of the verification program. The final check may be conducted during the final thermal-vacuum test.

A leak detector may be used to detect flow out of or into a sealed item.

The test should be conducted under steady-state conditions, (i.e., stable pumping, pressures, temperatures, etc). If time constraints do not permit the imposition of such conditions, a special test method should be devised.

##### 2.7.6.3 Acceptance Requirements

The above provisions apply to the acceptance testing of previously qualified hardware.

## SECTION 2.8

### CONTAMINATION CONTROL

Check the GSFC Technical Standards Program website at <http://standards.gsfc.nasa.gov> or contact the Executive Secretary for the GSFC Technical Standards Program to verify that this is the correct version prior to use.

## 2.8 Contamination and Coatings Engineering and Planetary Protection

The objective of the Contamination and Coatings Engineering Program is to decrease the likelihood that the performance of flight hardware, engineering test units, and GSE, and research endeavors, will not be unacceptably degraded by contaminants. The objective of a Planetary Protection Program is to protect solar system bodies (*i.e.*, planets, moons, comets, and asteroids) from contamination from Earth life, and to protect Earth from possible life forms that may be returned from other solar system bodies. This Section is organized as follows:

- 2.8.1 Contamination Engineering
- 2.8.2 Coatings Engineering (both optical and thermal)
- 2.8.3 Planetary Protection

### 2.8.1 Contamination

Since contamination control programs are dependent on the specific mission goals, instrument designs, planned operating scenarios, etc. it is necessary for each program to develop contamination requirements for each sensitive element based on contamination susceptibility, performance and lifetime requirements and cross-contamination potential. From the overall lifetime allowable contamination requirements, an allowable contamination budget will then be developed to allocate that amount among the various mission phases, so that the total end-of-life limit will be achieved. A governing Contamination Control Plan (CCP) which defines the complete contamination control program to be implemented for the mission will be written. The specific verification plans and requirements must be defined in the CCP. The supporting procedures that follow provide an organized approach to the attainment of the objectives so that the allowable contamination limit is not violated during each mission phase. The contamination engineering approach commences with concept and continues through end-of-life for the mission.

#### 2.8.1.1 Summary of Contamination Verification Process

- 3 Determination of contamination sensitivity;
- 4 Determination of a contamination requirements;
- 5 Determination of a contamination budget;
- 6 Development and implementation of a contamination control plan and supporting documents;
- 7 Development of contamination verification plans;
- 8 Performance of analytical modeling to predict contamination deposition; and comparison of prediction results to contamination requirements;
- 9 Performance of monitoring of hardware surfaces, air cleanliness, cleanrooms, purges, etc. to verify that requirements are being met.
- 10 Ongoing comparison between hardware cleanliness levels, and/or witness plate cleanliness levels, versus the contamination budget requirements for that phase of build-up or integration.
- 11 If at any time there is a noncompliance between the cleanliness level of the hardware and the requirement level expected for that phase of the mission, the Contamination Engineer should notify the Project. Together, the CC Engineer and the Project will

Check the GSFC Technical Standards Program website at <http://standards.gsfc.nasa.gov> or contact the Executive Secretary for the GSFC Technical Standards Program to verify that this is the correct version prior to use.

determine the cause of the non-compliance and put together a corrective action plan to ensure requirements will be met.

- 12 Such corrective action may include: additional cleaning, covers, purges, improving the level of the cleanroom, limiting cleanroom activities, re-assessing the requirement, etc.

Each of the above activities should be documented at each mission phase and submitted to the project manager for concurrence and approval. The Contamination Engineer should keep track of requirements compliance, and of monitoring/verification data during each mission phase. Should requirements be exceeded at any time, the Contamination Engineer will enact a process or approach for mitigating the requirements excursion and bringing the levels back within limits.

### 2.8.1.2 Contamination Engineering Approach

There is a general approach to performing contamination engineering for a project, which includes identifying requirements, performing analyses, verifying requirements through analytical methods, and later through monitoring methods. Should analytical results or monitoring methods show that requirements have been exceeded, there are a variety of corrective actions, additional mitigation methods, and further verification that should be exercised until requirements are met.

The basic approach which should be followed for all Contamination programs is:

- a) Assemble information on the spacecraft performance goals and design requirements.
- b) Identify sensitive surfaces, components, and systems and assign quantitative contamination requirements for each element.
- c) Evaluate information, history and flight data from previous missions; apply applicable "lessons learned" to current program.
- d) Design, document, and implement a comprehensive contamination control program for the spacecraft beginning with the concept definition phase, and continuing on through fabrication, assembly, integration and test, transport, launch, and on-orbit, and post-mission or retrieval mission phases.
- e) Study spacecraft design and identify potential "problem" areas. (e.g. acceptable vs. non-acceptable vent locations).
- f) Perform trade-off studies to evaluate technical adequacy, cost and schedule impacts, of proposed contamination control measures (e.g. performing bakeouts of components vs. incorporating Molecular Adsorbers).
- g) Perform laboratory testing whenever needed, to assess contamination potentials of materials, and to evaluate contamination levels versus performance degradation.
- h) Utilize special contamination mitigation devices and techniques, when appropriate: molecular adsorbers, special coatings, on-orbit covers for sensitive apertures, on-orbit heaters, special vent placements, etc.
- i) Work with the project to include on-orbit flight contamination monitors to measure mission contamination levels, if contamination is critical to the mission.
- j) Perform analytical modeling to predict expected contamination deposition levels for sensitive surfaces.
- k) Perform cleaning, vacuum bakeouts, and implement protection devices (covers, bags, containers, etc.) to minimize resultant contamination levels.
- l) Perform adequate monitoring and verification of contamination levels on and near the spacecraft during all assembly, integration and testing, transport, storage, and launch readiness mission phases.
- m) Monitor launch and on-orbit contamination environments, and/or evaluate the performance of spacecraft systems to determine effects of contamination.

Check the GSFC Technical Standards Program website at <http://standards.gsfc.nasa.gov> or contact the Executive Secretary for the GSFC Technical Standards Program to verify that this is the correct version prior to use.

- n) Develop “lessons learned” list for implementation on follow-on projects.

Check the GSFC Technical Standards Program website at <http://standards.gsfc.nasa.gov> or contact the Executive Secretary for the GSFC Technical Standards Program to verify that this is the correct version prior to use.



### 2.8.1.3 Contamination Sensitivities

An assessment should be made early in the program to determine whether the possibility exists that the item will be unacceptably degraded by molecular or particulate contaminants, or is a source of contaminants to other contamination sensitive hardware. The assessment should take into account all the various factors during the entire development program and flight including identification of materials (including quantity and location), manufacturing processes, integration, test, packing and packaging, transportation, and mission operations including launch and return to earth, if applicable. In addition, the assessment should identify the types of substances/materials that may contaminate and cause unacceptable degradation of the test item. Contamination is any substance that can cause deleterious effects on performance of the mission either through residence of material on a surface, deposition of nonvolatile residue, particles, degradation of a surface, cross contamination, bulk material outgassing, or interaction of any ambient, vacuum, or space environment with the surface or material returning to the surface.

If the assessment indicates a likelihood that contamination will degrade performance of the flight item or other sensitive hardware associated with the mission, a contamination control program should be instituted. The severity of contamination program should be in accordance with the importance of the item's function to mission success, its sensitivity to contamination, and the likelihood of its being contaminated.

### 2.8.1.4 Contamination Requirements

The amount of degradation of science performance that is allowed for critical, contamination-sensitive items should be established, usually by the Project Scientist with support from the project contamination engineer. Likewise, the amount of permissible degradation of key performance properties (thermal, optical, mechanical, etc.) of other contamination sensitive hardware (optics, solar arrays, thermal coatings, star trackers, mechanisms, power systems, etc.) that are necessary to support the mission should be determined by the designer of the hardware or the mission systems engineer. From these limits, the amount of contamination that can be tolerated, or the contamination requirements should be established. The rationale for such determination and the ways in which contaminants will cause degradation is the mission level requirement and should be described in the contamination control plan, and any project documentation or contract documentation necessary to ensure these contamination requirements are achieved.

### 2.8.1.5 Contamination Budget

Contamination budgets (a breakdown of the overall end-of-life allowable contamination levels) for allowable surface accumulation should be developed for all elements of the flight hardware and, when applicable, critical ground support hardware. Comprehensive outgassing rates may need to be developed to meet the specified budget allotments. The budgeted levels should reflect both the hardware's own sensitivity to contamination as well as the ability of the hardware to cross-contaminate to other hardware associated with the mission. The budget should describe the required outgassing rates and surface cleanliness levels through all phases of ground and mission operations up to end-of-life. The budgets should be expressed in terms of verifiable requirements – e.g, outgassing rates, partial pressures, surface cleanliness levels, visual cleanliness levels, etc. The necessary contaminant transport modeling and materials properties testing should be conducted as required for the various

Check the GSFC Technical Standards Program website at <http://standards.gsfc.nasa.gov> or contact the Executive Secretary for the GSFC Technical Standards Program to verify that this is the correct version prior to use.

environments and factors which affect contaminant generation, transport and accumulation (e.g, mass transport in vacuum, particle fallout in cleanroom, particle redistribution during launch, atomic oxygen, radiation, uv, etc. ) to validate the budgeting efforts. The budget should be monitored to ensure that, given the actual contamination, the mission performance will remain acceptable. In the event that contamination build-up predictions are not borne out, corrective action should be taken.

Cleaning, thermal vacuum bakeout, and other mitigations may be used to bring hardware into compliance with the budget. When such mitigations cannot be performed or can only be performed a limited number of times, then protective measures may be required to maintain the contamination budgets throughout ground, launch, and post-launch operations. Such measures could include: bagging, containers, GSE/flight barriers, baffles, covers or doors, purging, etc. Contamination avoidance methods, such as cleanrooms and instrument covers, will affect the budget and a general description of their usage should be included.

#### 2.8.1.6 Contamination Control Plan (CCP)

The CCP is the most important contamination control document for any program. A detailed contamination control plan should be prepared that describes the requirements and procedures to be followed to control contamination. It should establish the implementation plans and describe the methods that will be used to measure and maintain the levels of cleanliness required during each of the various phases of the hardware lifetime.

From the overall end-of-life allowable deposition requirements, the breakdown of specific allowable contamination levels, at progressive points in the build-up, integration, testing, launch readiness process, and on-orbit mission phases should be derived. This breakdown is often called a contamination “budget” and should be clearly presented in the CCP.

The CCP should also specify when and by what methods the various contamination requirements will be verified. It is good contamination practice to include frequent verification of contamination levels (especially during events) so that problems associated with excess contamination levels can be identified and solved as soon as possible.

The CCP should also present the overall plan for controlling contamination, from fabrication and assembly, throughout integration and testing, and continuing with launch site, launch, and on-orbit plans. Any laboratory and analytical support should also be identified in the CCP. All necessary supporting documents should be referenced in the CCP.

##### 2.8.1.6.1 Supporting Contamination Documentation

The following documentation list represents the type of supporting documents which may be required for a project:

- CCP Implementation Plan
- Hardware Cleaning Procedures
- Hardware Cleanliness Verification Procedures
  - Molecular Wash Method
  - Molecular Wipe Method
  - Particulate Tape Lift Sampling
  - Particle Counting Method

Check the GSFC Technical Standards Program website at <http://standards.gsfc.nasa.gov> or contact the Executive Secretary for the GSFC Technical Standards Program to verify that this is the correct version prior to use.

- Optical Measurement Methods
- Actual instrument throughput/performance measurements
- Witness Plate Measurements
- Cleanroom Personnel Training/Certification Documents
- Cleanroom Personnel Operations Requirements
- Cleanroom Operating Procedures
- Approved Materials Lists and processes
- Cleanroom Monitoring Methods
- Purging Plans
- Hardware Bagging Requirements
- Contamination Protection Methods
- Material/Hardware Outgassing Certification Plans
- Thermal Vacuum Bakeout Plans and Procedures
- Transportation/Storage Cleanliness Plans
- Launch Vehicle/Payload Interface Documents
- Launch Site Cleanliness Requirements
- Launch/On-orbit Contamination Requirements
- Testing Results Reports (Thermal Vacuum Bakeouts, Vibration Testing, Functional Testing, etc.)
- Hardware Certification Logs and Anomaly Reports
- Lessons Learned Summary Report

The basic standards and practices, and some procedural documents already exist in open literature and are controlled by various technical societies (ASTM, IES, etc.). A spacecraft project may utilize these documents and reference them in the higher level documents, rather than develop completely new documents.

#### 2.8.1.7 Contamination Engineering During Design

From the earliest stages of a program, iterative analyses must be done to determine contamination sensitivities of hardware and contamination transport (molecular outgassing, diffusion, particle redistribution, contact transfer, plume, venting, etc.) These analyses need to consider not only the hardware's own contamination sensitivity but also the sensitivity of other hardware and the allowable degradation of performance – especially science -- by contamination. Likewise, a general plan for achieving the outgassing, surface cleanliness, and other critical cleanliness levels should be formulated. It should identify elements that will significantly affect the complexity or difficulty of the contamination control program so that the appropriate cost, schedule, performance, and risk trades may be made in conjunction with the project management. The need for protective design elements (reducing lines of sight of contaminating surfaces to contamination sensitive surfaces, doors, purges, cold cups, molecular traps, cleanable surfaces, bakeout flight heaters, etc.) to assure performance or reduce overall programmatic cost should be identified as early as possible in the program.

Standard material selection requirements that are often part of contracts and specifications for hardware may need to be made more stringent to cost effectively achieve performance requirements. The contamination engineer should determine if more stringent criteria (particle generation, water content, outgassing, "as-used" temperatures, etc.) are required as early as possible in a program to minimize impact to cost and schedule. At a minimum, established material screening criteria for vacuum stability (ASTM E 595, JSC 0700 Vol. XIV, and NASA Reference Publication 1124) should be imposed in project requirements documents. These

Check the GSFC Technical Standards Program website at <http://standards.gsfc.nasa.gov> or contact the Executive Secretary for the GSFC Technical Standards Program to verify that this is the correct version prior to use.

screening criteria exist not only for contamination considerations, but also to assure that material properties remain stable after exposure to vacuum. While useful for many applications, these screening criteria are insufficient for many state-of-the-art instruments and spacecraft designs. Material selection criteria for particle generation, cleanability, specific chemical restrictions, and other unique mission specific parameters may have to be defined and implemented in the appropriate contractual and programmatic documents. The ASTM E1559 tests material outgassing according to on-orbit source and receiver predicted temperatures.

#### 2.8.1.8 Contamination Engineering Analyses

It is recommended that a detailed analysis plan be developed for each spacecraft mission. Usually, a preliminary analysis is performed early in the program, so that results may be used to aid in making design decisions. Then, once the final design is established, a detailed analysis is performed and fine-tuned. This stage aids in verifying the spacecraft design and performance expectations, and is also used to set bakeout acceptance criteria for the hardware. A final, flight prediction analysis is typically performed near the end of spacecraft integration and test, to establish the final estimates of on-orbit contamination levels.

##### 2.8.1.8.1 Molecular Contamination Analyses

These analyses generally consist of utilizing an existing analytical tool (e.g. Molflux, CAP, ISEM, DSMC, and an entire library of plume definition/effects tools), creating a geometric model of the spacecraft (with critical surfaces well-defined), assigning materials and materials outgassing rates to each surface, assigning temperature profiles to each surface, and then exercising the code. Results are usually reported in mass/unit area, and additional iterations of the runs (with different temperatures, materials, etc.) may easily be accomplished. Once the mass/unit area values are ascertained, it is also possible to perform “effects analyses” to predict the resulting impact on performance. For example, a modeling analysis may predict that 100 Angstroms of silicone will deposit on a critical surface. Then, using different analytical tools (which are usually based on experimental test programs), it is possible to evaluate performance of the optical system with this coating of 100 Angstroms of silicone. A 100 Angstrom layer of silicone, within a UV instrument, can mean significant degradation. Additionally, if one considers specific on-orbit parameters (such as solar exposure), it is possible to further assess the impacts via analytical methods.

Materials properties become an important input factor in the molecular analyses. Outgassing rates, and reemission rates are both input into the codes. The industry has, over the years, developed an extensive materials properties data base, and where possible, the input data is obtained from these previously performed materials tests. It is often necessary to perform materials outgassing testing on specific materials, for which no other data exists.

##### 2.8.1.8.2 Particulate Contamination Analyses

The particle analyses vary in methodology, depending on the mission phase. Differing physical principals apply to the various mission phases (e.g., particle fallout values are different in 1g environments versus 0 g environments).

Check the GSFC Technical Standards Program website at <http://standards.gsfc.nasa.gov> or contact the Executive Secretary for the GSFC Technical Standards Program to verify that this is the correct version prior to use.

For the ground-based assembly, integration, test, transport, storage, and prelaunch phases, calculations are made based on exposure to the various cleanroom environments. Parameters that affect this analysis are:

- How clean is the air?
- How long is the spacecraft exposed?
- Number of personnel working on and near the spacecraft
- Other activities performed near the spacecraft (drilling, sanding, painting, etc.)
- Test chamber attributes and operations
- Number of scheduled cleanings
- Methods of protection employed

Based on these analyses, it is possible to identify potential hazards or threatening timeframes for the spacecraft critical surfaces, and preparations to protect the spacecraft may be made, well in advance of the activities. In addition, these analysis results may be used to determine the schedule of cleaning for the spacecraft. The analysis may show that contamination builds up quickly in one facility versus another, and more frequent hardware cleaning may be advisable.

For the launch period, vibration and acoustics levels act to remove and relocate particles from surfaces. In addition, the changing gravity levels, and venting of the spacecraft and launch vehicle payload volume become important influencing parameters. There are models and codes to evaluate these events, and determine the resulting particle redistribution during launch.

During the on-orbit mission phases, particles become dislodged from surfaces due to spacecraft operations (launch vibro-acoustic modes, solar array openings, aperture cover ejections, attitude and altitude changes) and other phenomena such as micrometeoroid impacts. These particles tend to be ejected into a type of "orbit" around the spacecraft and could potentially interfere with instrument and sensor viewing. There are codes that predict these trajectories (based on particle size, shape, relative velocities of spacecraft and particle, and mass), and then predict the potential for re-encounter with the spacecraft, and subsequent deposition.

In all cases, once the particle deposition predictions are determined, it is then possible to perform effects analyses. For example, after predicting the particle deposition (number and sizes of particles) on an optical element, analyses may be performed to assess the scattering associated with the particles on a mirror, or the transmission loss due to particles obscuring a lens. With these analysis results, spacecraft performance may be predicted, and corrective actions may be taken. At the very least, by knowing the level of particle contamination and the predicted effects, it is possible to more effectively evaluate the flight data (making data corrections for the spurious particulate effects).

#### 2.8.1.8.3 Other Analyses

There are many other analyses performed for spacecraft programs that are related to contamination. These include:

- Atomic Oxygen Prediction Analyses
- Predicts atomic oxygen fluence

Check the GSFC Technical Standards Program website at <http://standards.gsfc.nasa.gov> or contact the Executive Secretary for the GSFC Technical Standards Program to verify that this is the correct version prior to use.

- Can predict materials erosion rates
  - Combined Effects Analyses (e.g. UV plus Atomic Oxygen)
  - Contamination Effects Analyses
- Thermal properties changes
- Optical properties changes
- Lifetime and performance impacts
  - Materials Properties Analyses
- Specific analyses on materials outgassing rates and cumulative amounts
- Particulate generation analyses for specific materials
- Materials aging studies

#### 2.8.1.9 Contamination Engineering During Integration and Test

The goal of the integration and testing phase is to perform the necessary activities without compromising the cleanliness integrity of the spacecraft hardware. It should be noted, here, that there are generally some testing activities which must be accomplished in non-cleanroom environments (e.g. vibration/acoustics testing facilities are typically not cleanrooms). Significant pre-planning, the use of protection devices (covers, bags, etc.), and frequent sampling of cleanliness levels, must be implemented for these testing periods. Contamination control during the integration phase becomes crucial to the success of the overall mission. Many programs fall short during this phase, without realizing that this is where the strictest of attention to details such as contamination control become all-important.

During spacecraft integration, all systems, subsystems, boxes, solar arrays, etc. are merged together and now constitute the entire spacecraft program. It is especially important to identify the most critical elements (usually the optical and thermal control elements) and to plan integration activities, while keeping in mind the strict contamination requirements of these crucial systems.

The spacecraft is generally maintained only in cleanroom environments and bagging and protection of the entire spacecraft is recommended during all downtimes.

A major part of the development of the contamination control plan is to develop a cost-effective integration and test plan. There are often many possible means of maintaining a particular cleanliness level. It is important to work with the program to determine which solution(s) best meet the project's overall cost, risk, schedule, and, most importantly, mission success criteria. Critical elements that contribute to a program's overall cost and success include: type of facility, gowning requirements, Ground Support Equipment design and cleanliness, cleaning processes, thermal vacuum plans and tests, bagging provisions, shipping and handling provisions, contamination verification and testing, etc. Contamination requirements need to be established in the contamination control program that addresses these elements and any others that can prevent contamination or reduce the risk of contamination.

A thorough cleanliness monitoring and verification program must be enacted during integration and testing activities, and checked regularly. Each major integration event and testing activity must be separately monitored to characterize the levels of contamination which may have occurred during that unique period. This serves to prove that the integration and/or testing event was a "clean" event, or aids in forensics should there be an anomaly during one of these activities. All of the testing requirements are delineated in the CCP and supporting documents.

Check the GSFC Technical Standards Program website at <http://standards.gsfc.nasa.gov> or contact the Executive Secretary for the GSFC Technical Standards Program to verify that this is the correct version prior to use.

#### 2.8.1.10 Thermal Vacuum Bakeouts

The importance of the thermal vacuum bakeout and certification phases for space hardware has become a dominant factor in Contamination Engineering planning. Experience has shown that taking the time, at this point in the program development, to fully bakeout and certify each component, assembly, subsystem, etc., has significant pay-offs later during the on-orbit mission phase, reference Hubble Space Telescope's Wide field Planetary Camera II ultraviolet performance. Clearly, by reducing the spacecraft outgassing levels in a controlled vacuum chamber during this ground phase, the amount of material left to outgas during on-orbit periods is diminished. For those spacecraft and instruments which are sensitive to even small amounts of molecular contamination, it is important to plan for and cost-out a thorough vacuum bakeout and certification program.

The general philosophy behind vacuum bakeouts and certification of space hardware is as follows:

- Commence with bakeouts at the parts level, if possible. Bakeout hardware at the highest temperature possible.
- Set quantitative acceptance criteria for each bakeout. These criteria should be based on the total allowable outgassing level for the spacecraft. Usually computer modeling analyses aid in the determination of the allowable outgassing level for hardware.
- Do not accept hardware which does not meet the acceptance criteria or adjust the outgassing cleanliness budget accordingly.
- As parts become assembled, often, the maximum temperature limits become lower. Bakeouts at lower temperatures are less effective, and take considerably longer to complete.
- Develop a detailed Thermal Vacuum Bakeout and Certification Plan for your program. Include the overall plan, schedule, need for instrumentation, and QCM acceptance criteria, as well as a list of the responsible individuals to contact during the test.

#### 2.8.1.11 Spacecraft Transportation and Storage Phases

During transportation and storage, it is important to preserve the state of cleanliness of the space hardware. Generally this means sufficiently protecting the hardware via covers, containers, bagging, etc. and often means employing a high purity purging of flight hardware. Develop a purge plan early in the program to accommodate purge system procurement.

#### 2.8.1.12 Launch Site Contamination Control

The purpose of a Launch Site Contamination Control Plan (LSCCP) is to identify all contamination requirements, all interface requirements, all necessary equipment and supplies needed at the launch site, all necessary personnel requirements, an overall schedule, and a detailed plan of activities for the launch site. Contamination Engineers should work with the launch site teams, spacecraft and instrument teams, and support launch site activities up through launch.

#### 2.8.1.13 Launch Vehicle and Companion Payload Considerations

Check the GSFC Technical Standards Program website at <http://standards.gsfc.nasa.gov> or contact the Executive Secretary for the GSFC Technical Standards Program to verify that this is the correct version prior to use.

The following information must be obtained and integrated into the overall contamination control program: Obtain and review system information regarding the launch vehicle and companion payloads.

- Evaluate the mission scenario and timeline.
- Identify potential contamination sources; attempt to qualitatively prioritize the magnitude of threat posed by the launch vehicle and companion payload sources:
  - Fairing materials
  - Fairing surface cleanliness levels
  - Primary engine firings and plumes
  - Secondary engine firings and plumes
  - Launch vehicle venting
  - Launch pad purging and T-0 purges, including materials and certifications of gas at point of delivery.
  - Companion payload materials and venting
  - Companion payload ejection and orbit insertion (springs, pyrotechnic devices, engine firings, etc.)
  - Effects of Helium on spacecraft system performance as applicable.
- Perform modeling and plume analyses (typically during CDR timeframe) to quantify contamination threats.
- Develop resolution methods, if required, such as:
  - Implement a change-out or substitution of specific materials
  - Improve cleanliness levels of launch vehicle and/or companion payload (such as performing additional vacuum bakeout of components, plan for more rigorous cleaning of surrounding launch vehicle or companion payload surfaces, etc.)
  - Design protective shields or barriers for your spacecraft or
  - Change ejection and orbit insertion methods

#### 2.8.1.14 Launch and Orbit Insertion Mission Phases

There are several parameters associated with the launch and orbit insertion mission phases which may be discussed and adjusted to fit individual spacecraft needs. For example, it may be possible to work with the launch vehicle team to adjust the retro maneuvers to minimize plume impingement on the released spacecraft. Usually, a detailed analysis and justification for these types of adjustments is required, before approval is given.

#### 2.8.1.15 On-Orbit Through End-of-Life Mission Phases

There are a number of actions which may be taken during the on-orbit through end-of-life mission phases to minimize contamination levels and even to “clean-up” certain surfaces while on-orbit. Careful planning and in some cases, special equipment may be necessary to carry out contamination control measures at this stage of a mission.

For spacecraft which are sensitive to molecular contaminants, all on-orbit sources must be minimized. This may include inhibiting engine firings, redirecting vents and other high outgassing sources.

Check the GSFC Technical Standards Program website at <http://standards.gsfc.nasa.gov> or contact the Executive Secretary for the GSFC Technical Standards Program to verify that this is the correct version prior to use.

For instruments which require clear FOV operations, it may be necessary to inhibit certain on-orbit operations during viewing times. Inhibits of vents, mechanisms, solar array movement, engine firings, and any other particle “jostling” activities may be required.

In the case of spacecraft which are sensitive to photopolymerized molecular contaminants, it is recommended that solar exposure be limited. This may mean designing on-orbit maneuvers such that sensitive elements are not exposed to solar illumination, thus minimizing the risk of photopolymerization of contaminants.

The planning for the operations of any aperture doors or covers must be evaluated well in advance of the actual flight. It may be necessary, however, based on actual mission circumstances, to utilize the aperture doors and covers in order to prevent further contamination of critical surfaces.

In the case of lower altitude spacecraft, with surfaces which are vulnerable to the effects of atomic oxygen degradation (erosion), it is recommended that sensitive surfaces never be oriented into the RAM direction. Or if this is impractical, it may be possible to design barriers to “shadow” or protect the vulnerable surfaces from the atomic oxygen environment.

Ironically, the atomic oxygen environment may also serve a beneficial purpose for other surfaces. For example, if a fairly stable surface become contaminated with a molecular residue, it may be possible to deliberately orient the surface in the RAM direction so that it is exposed to atomic oxygen impingement, which usually “erodes” away the contaminant layer, leaving the substrate surface once again clean.

It may also be possible not only to deliberately locate vents in areas of the spacecraft which pose little threat the sensitive elements, but also to design vent barriers or deflectors to deflect venting products (usually considered contaminants) away from sensitive spacecraft elements. Molecular Adsorber pucks may be utilized in vent locations to “capture” molecules in high outgassing volumes.

For sensitive missions, it is always advisable to design and fly an accompanying contamination monitor with the spacecraft so that direct measurements of accumulated contamination may be confirmed.

Another aspect of this mission phase which is often neglected is the ability of engineers to evaluate mission performance data (actual optical measurements, temperature data, etc.) and to derive what the effects of contamination might be. For example, if the temperature of a thermal control surface is rising faster than anticipated, it may be because of layer of contamination has deposited on it, and has changed the absorptance properties of the surface, which in turn is causing the surface to heat up faster. Knowing this information, it may be possible to take corrective action, such as exposing the surface to atomic oxygen (to erode the contaminant layer) or to modify the thermal system (via computer commands) to rely more heavily on another, uncontaminated thermal component for spacecraft temperature control.

If the spacecraft is demonstrating unexpected responses or seemingly incorrect data, is has often been possible to quickly perform modeling analyses, or perform an experimental investigation to simulate the actual environment (temperatures, solar activity, etc.) being experienced by the spacecraft. Then, is has been possible to verify what is happening,

through these ground-based investigations, and help to prevent further degradation, or devise scenarios for correcting or compensating for the on-orbit anomaly.

In recent years, much attention has been paid to the possibility of performing on-orbit cleaning of contaminated surfaces and systems. The most obvious method for achieving this is designing heater systems under sensitive elements (mirrors, lenses, detectors, etc.) which can be turned on to heat-up and “outgas” contaminants from surfaces. This method has already be implemented on a number of spacecraft in the past, including the HST.

#### 2.8.1.16 Spacecraft Post-Mission and Follow-on Program Phases

It is often during the post-mission analysis of on-orbit performance that the aerospace community learns the most valuable lessons from the mission. Many program improvements, and “lessons learned” have resulted from taking a clear and complete look at what happened during the life of the spacecraft.

## 2.8.2 Coatings Engineering

Coatings Engineering for a spacecraft mission, instrument, or component involves 3 main-steps. An additional step may be required where a coating need to be qualified:

- **Assessment of Mission Needs:** Selection of coatings for various applications to meet *thermal and optical* performance requirements for individual surfaces or systems is the first step. Determination of Beginning of Life (BOL) and End of Life (EOL) requirements is then assessed. Thermal radiative property predictions and preliminary testing may be required to determine that the selected coatings are valid. Documentation for methods of applications, curing, handling, and special instruction must be developed.
- **Research & Development or New Coatings Development:** If necessary, due to project performance needs, new or tailored coatings may be required and research and development may be required to develop flight worthy coatings. Absorptance tailoring of Coatings, emittance tailoring of coatings, new application techniques, composite coatings, etc. may require development to support the mission.
- **Coatings Application:** Once agreed upon, the application of the Thermal Control Paints, Thin Film Coatings, Dielectric Coatings, Conductive Coatings, Lacquers, Tapes, Molecular Adsorber Coatings, etc. will be performed. Full validation of adhesion, thickness, smoothness, bonding, coverage, and integrity of the application should be performed after application, until coating is acceptable and meetings requirements.
- **Coatings Flight Qualification and Measurements:** If a flight coatings needs to be qualified for flight, the coating engineer will design a test program accommodating any special testing required by the project specific requirements, such as: mission parameters, spacecraft configuration, desired thermal/optical coating's properties, coating application, need for a conductive coating, space environmental effects and/or contamination issues. As dictated by the coatings engineer and the project, a set of post application characterization measurements will be performed to verify the characteristics of the coating. These may include: Optical Property Characterization, Thermal Radiative Property Characterization, Hemispherical Emittance Characterization, Bi-Directional Reflectance Distribution Function (BRDF), Light Scattering/Surface Specularity, Electrostatic Discharge Testing, UV Degradation Testing, Thermal Cycle Testing, Solar Wind Testing, and Outgassing Testing.

To design a thermal control system that address the mission's requirements, the thermal radiative properties and durability of the material must be obtained through thermal optical/radiative property measurement and space environmental testing.

Thermal Optical/Radiative Properties (Reflectance =  $\rho$ , Transmittance =  $\tau$ , Absorptance =  $\alpha$ , and Emittance =  $\epsilon$ ) are used to evaluate a material's ability to maintain temperatures. The reflectance of a material's surface is measured over the Infrared, Visible and Ultraviolet regions of the electromagnetic spectrum to calculate the solar absorptance and over the infrared region to calculate emittance. Thermal coatings are tested for good coating adherence to the substrate through Coating Adhesion testing and/or thermal cycle testing.

Check the GSFC Technical Standards Program website at <http://standards.gsfc.nasa.gov> or contact the Executive Secretary for the GSFC Technical Standards Program to verify that this is the correct version prior to use.

### 2.8.2.1 Key Verification Milestones for Coatings Selections and Testing

- System Requirements Review (SRR)
  - Conceptual Design presented - including which coatings are planned for key thermal and optical surfaces.
- Preliminary Design Review (PDR)
  - Major trade studies complete
  - A complete design, meets all requirements within system resources (power, mass, volume, cost, schedule)
  - All coatings for key thermal control surfaces and optical surfaces should now be assigned and preliminary test data available at the review
- Critical Design Review (CDR)
  - Detailed design complete, ready to fabricate, and assemble/integrate
  - Results of development tests, activities
  - Test concepts presented
  - Complete coatings selection, design, application methodology, environmental test data, etc. will be presented at CDR
- Pre-Environmental Design Review (PER)
  - Details since CDR presented: design changes, problems, detailed analysis complete
  - Results of 1<sup>st</sup> complete system functional
  - Details of planned environmental tests: EMI, Mechanical (vibe, acoustics), Thermal Vac & Balance (TB)
  - All coatings will have been applied, tested, and validated.
- Pre-Ship Review (PSR)
  - Results of testing, including problems & resolution; TB correlation, final flight predictions.
  - Plans for ship, launch site ops
  - Any touch-up of coatings will occur as needed
- Launch Readiness Review (LRR)
  - Report on launch site preps, all paperwork complete, staff & plans for L&EO
  - Pre-launch touch-up will occur as needed

### 2.8.3 Planetary Protection

Planetary protection is essential for several important reasons: to preserve our ability to study other worlds as they exist in their natural states; to avoid contamination that would obscure our ability to find life elsewhere.

Planetary Protection during spacecraft design, fabrication, assembly, integration and testing, follows a similar approach to that of contamination control, with the difference that the goal is to minimize, prevent, clean, measure, and verify the microbial contamination levels on spacecraft surfaces.

Planetary Protection encompasses a set of requirements pertaining to spacecraft hardware and missions involving (1) the control of terrestrial microbial contamination associated with robotic space vehicles intended to land, orbit, flyby, or otherwise encounter extraterrestrial solar system bodies, and (2) the control of contamination of the Earth and the Moon by extraterrestrial material collected and returned by robotic missions. Detailed compliance and verification requirements for Planetary Protection programs for NASA missions are found in

Check the GSFC Technical Standards Program website at <http://standards.gsfc.nasa.gov> or contact the Executive Secretary for the GSFC Technical Standards Program to verify that this is the correct version prior to use.

NPR 8020.12C (or latest version), "Planetary Protection Provisions for Robotic Extraterrestrial Missions", and NPD 8020.7G, "Biological Contamination Control for Outbound and Inbound Planetary Spacecraft" (Revalidated 11/25/08).

### 2.8.3.1 Classification of Missions

Specific planetary protection requirements for each planned mission will be determined by the NASA Planetary Protection Office (PPO), in accordance with the governing documents, and consistent with the policy and guidelines of the Committee on Space Research (COSPAR), recommendations of the Space Studies Board of the National Research Council (NRC), and advice from the NASA Advisory Council. Requests for categorization of missions and associated mission requirements must be submitted to the PPO during the mission design phase (before the completion of the draft Planetary Protection Plan) by the mission Project Manager. Such correspondence must be accompanied by a mission description and must include a request and justification for a specific mission categorization. The PPO will respond, in writing, with the appropriate categorization, conveying such explanatory information or supplemental conditions as may be appropriate. Subsequent approval of a mission's Planetary Protection Plan will constitute formal categorization of the mission.

### 2.8.3.2 Planetary Protection Categorization of Missions

Each planetary mission will fall into one or more categories based on the planetary protection priorities of each extraterrestrial solar system body and the mission plan. Planetary protection priorities and corresponding mission categories are given in the following table. Each category has increasingly more severe requirements as the Mission Category Level increases. Documentation, microbial cleanliness, sampling, monitoring and verification requirements become more complex. The NASA Headquarters Planetary Protection Office (PPO) is responsible for reviewing each planetary mission, including planned operations, possible unplanned events involving planets, asteroids, comets, etc., and then assigning a Planetary Protection Category and Mission Type to each program. The PPO must follow the progress and adherence to Planetary Protection requirements and verification plans throughout the life of each mission.

<b>Planetary Targets Priority</b>	<b>Mission Type</b>	<b>Mission Category</b>
Not of direct interest for understanding the process of chemical evolution, or where exploration will not be jeopardized by terrestrial contamination. No protection of such planets is warranted and no requirements are imposed.	Any	I
Of significant interest relative to the process of chemical evolution but only a remote chance that contamination by spacecraft could jeopardize future exploration.	Any	II
Of significant interest relative to the process of chemical evolution and/or the origin of life or for which scientific opinion provides a significant chance of contamination which would jeopardize a future biological experiment or exploration program(s).	Flyby, Orbiter	III

Check the GSFC Technical Standards Program website at <http://standards.gsfc.nasa.gov> or contact the Executive Secretary for the GSFC Technical Standards Program to verify that this is the correct version prior to use.

Of significant interest relative to the process of chemical evolution and/or the origin of life or for which scientific opinion provides a significant chance of contamination which would jeopardize biological experiments or exploration programs(s).	Lander, Probe	IV
Any Solar System Mission	All Earth-Return	V

Notes:

- 1) For missions that target or encounter multiple planets, more than one category may be specified for planets targeted or encountered.
- 2) For missions utilizing gravity assist means of a flyby of another planet, requirements will usually be those for the target requiring the higher degree of protection.

### 2.8.3.3 Planetary Protection Plan Development (Categories II-V)

Each Planetary Mission (Categories II-V) is required to produce and follow a Planetary Protection Plan. The Planetary Protection Plan should be the primary planning document describing how a planetary flight project will meet its planetary protection requirements. The Planetary Protection Plan should indicate planned conformance to those requirements and must include, as a minimum, the items given in the following outline (see below). It is recognized that each project will prepare various other documents that may adequately cover some of the topics in the outline (e.g., the Project Plan may thoroughly cover the subject of Planetary Protection Management). In such instances, it is suggested that the Planetary Protection Plan include only the major aspects of the topic and that free reference be made to the basic project documents that provide specificity.

The Planetary Protection Plan must include, but is not limited to, the items given in the following outline:

- ▶ General
- ▶ Introduction
- ▶ NASA Planetary Protection Constraints
- ▶ Designation of Mission Category
- ▶ Planetary Protection Specifications
- ▶ Planetary Protection Management and Organization
- ▶ Organization Description
- ▶ Responsibilities and Relationships
- ▶ System Interface Management
- ▶ Contractor Management
- ▶ Data Management
- ▶ Documentation
- ▶ Identification of References and Applicable Documents
- ▶ Facilities
- ▶ Identification and Description of Controlled Facilities
- ▶ Activities Performed
- ▶ Hardware Affected
- ▶ Schedules
- ▶ Identification of Milestones
- ▶ Preliminary Schedules

Check the GSFC Technical Standards Program website at <http://standards.gsfc.nasa.gov> or contact the Executive Secretary for the GSFC Technical Standards Program to verify that this is the correct version prior to use.

In addition, the following subsidiary plans should be prepared when required for the particular category assigned:

1. Contamination Analysis Plan
2. Microbiological Assay Plan
3. Microbial Reduction Plan
4. Earth Safety Analysis Plan

#### 2.8.3.4 Measurements and Verification

Specific constraints imposed on spacecraft involved in solar system exploration will depend on the nature of the mission and the identity of the target body or bodies. These constraints will take into account current scientific knowledge about the target bodies through recommendations from both internal and external advisory groups, but most notably from the Space Studies Board of the National Academy of Sciences. The most likely constraints on missions of concern will be a requirement to reduce the biological contamination of the spacecraft, coupled with constraints on the spacecraft operating procedures, an inventory of organic constituents of the spacecraft and organic samples and restrictions on the handling and methods by which extraterrestrial samples are returned to Earth. In the majority of missions, there will also be a requirement to document spacecraft flyby operations, spacecraft impact potential and the location of landings or impact points of spacecraft on planetary surfaces or other bodies. Specific requirements (reviews, documentation, and levels of cleanliness) are detailed in implementing procedures and guidelines, primarily NPR 8020.12, "Planetary Protection Provisions for Robotic Extraterrestrial Missions," and will be used to measure adherence to this directive.

#### 2.8.3.5 Documentation Requirements for Planetary Protection Requirements and Verification

Since Planetary Protection includes a similar approach as the contamination control approach, there are a number of documentation requirements, analyses reports, and monitoring reports needed to satisfy Planetary Protection verification requirements. Below is a summary of documentation requirements.

- Category I missions:
  - Certification of mission as Category I relieves a project of all further planetary protection requirements.
- Category II missions:
  - A Planetary Protection Plan outlining intended or potential impact targets.
  - Brief Pre- and Post-Launch Planetary Protection Reports detailing impact avoidance strategies.
  - End-of-Mission Report providing the final actual disposition of launched hardware and impact location.
- Category III missions:
  - A Planetary Protection Plan that details the planned approach to compliance with planetary protection requirements, including subsidiary plans.
  - A Pre-Launch Planetary Protection Report which documents that all requirements have been met (note that an inventory of bulk constituent organics, if the probability of impact is significant, must be included in the Pre-Launch Planetary Protection Report).
  - A Post-Launch Planetary Protection Report that updates the Pre-Launch Planetary Protection Report.

Check the GSFC Technical Standards Program website at <http://standards.gsfc.nasa.gov> or contact the Executive Secretary for the GSFC Technical Standards Program to verify that this is the correct version prior to use.

- An End-of-Mission Report which provides a complete report of compliance, the final actual disposition of launched hardware, and, in the case of accidental impact, the probable location of impact and its region of uncertainty.
- Category IV missions:
  - A Planetary Protection Plan that details the planned approach to compliance with the implementation requirements (e.g., mission description, probability estimates, microbial burden estimates, contamination analysis plan, assay plan, microbial reduction plan).
  - A Pre-Launch Planetary Protection Report that documents the degree to which all requirements have been met and that must include the values of the microbial burden at launch and the organics inventory.
  - A Post-Launch Planetary Protection Report that updates the Pre-Launch Planetary Protection Report.
  - An End-of-Mission Report that provides a complete report of compliance and the final disposition of all launched hardware.
  - An inventory of bulk constituent organics that includes:
    - Parts lists, material lists, and other program documentation containing data relevant to organic material identification that are prepared by a flight project to specify and control the materials that are included in a vehicle destined for planetary landing.
  - The locations of landings and impact points (determined and defined as accurately as mission constraints permit) of major components of space vehicles on the planet surface,
  - Estimates of the condition of each landed spacecraft to assist in calculating the spread of organic materials.
- Category V missions. Missions categorized as "Unrestricted Earth return" have outbound phase requirements, only (*see above requirements*). Missions categorized as "Restricted Earth return" require:
  - A Planetary Protection Plan, including outbound phase requirements, if any, and an Earth Safety Analysis Plan.
  - A Pre-Launch Planetary Protection Report, including outbound phase requirements, if any, that must document the degree to which all Earth-return requirements to be attained prior to launch have been met.
  - A Post-Launch Planetary Protection Report, including outbound phase requirements, if any, to update the Pre-Launch Planetary Protection Report with respect to Earth-return requirements.
  - After sample collection, a report analogous to the outbound phase launch report: i.e., an Earth Pre-Launch Report.
  - An Earth Pre-Entry Report demonstrating readiness to enter the Earth's atmosphere in compliance with planetary protection requirements.
  - An End-of-Mission Report to address compliance with requirements for the protection of the Earth's biosphere and detailing the transfer of the samples to an appropriate containment facility.
  - A Sample Pre-Release Report to provide verification of sample analysis procedures subsequent to the End-of-Mission and demonstrating that any planned sample release will not harm the Earth's biosphere.

Check the GSFC Technical Standards Program website at <http://standards.gsfc.nasa.gov> or contact the Executive Secretary for the GSFC Technical Standards Program to verify that this is the correct version prior to use.

## SECTION 2.9

### END-TO-END TESTING

## 2.9 END-TO-END COMPATIBILITY TESTS AND SIMULATIONS

### 2.9.1 Compatibility Tests

The end-to-end compatibility test encompasses the entire chain of payload operations that will occur during all mission modes in such manner as to ensure that the system will fulfill mission requirements. The mission environment should be simulated as realistically as possible and the instruments to the extent practical should receive stimuli of the kind they will receive during the mission. The RF links, ground station operations, and software functions should be fully exercised. When acceptable simulation facilities are available for portions of the operational systems, they may be used for the test instead of the actual system elements.

The specific environments under which the end-to-end test is conducted and the stimuli, payload configuration, RF links, and other system elements to be used must be determined in accordance with the characteristics of the mission.

### 2.9.2 Mission Simulations

After compatibility between the network and the user facility have been demonstrated, data flow tests should be performed that exercise as much of the total system as possible. Once the data flow paths have been verified, mission simulations are enacted to validate nominal and contingency mission operating procedures and to provide for operator training. To provide ample time for checkout of the Mission Operations Center (MOC), it is essential that mission operators take part in mission simulations from the early stages.

Mission simulations are the responsibility of the mission operations manager and should involve all participating elements and operating personnel (from project and support elements).

# **APPENDIX A**

## **GENERAL INFORMATION**

## Appendix A – General Information

Acoustic Fill effects

The acoustic sound pressure level in the area between the payload and the payload fairing, or orbiter side walls, increases as the gap decreases. Thus for large payloads, a fill factor is often used to adjust for this effect.

NASA-STD-7001, Payload Vibroacoustic Test Criteria recommends the use of the following acoustic Fill Factor:

$$\text{Fill Factor (dB)} = 10 \text{ Log} \left\{ \frac{\left(1 + \frac{C_a}{2fH_{\text{gap}}}\right)}{1 + \frac{C_a}{2fH_{\text{gap}}} (1 - \text{Vol}_{\text{ratio}})} \right\}$$

where:  $C_a$  is the speed of sound in air (typically 344.4 meters/second, 1130 ft/sec, or 13,560 in/sec)  
 $f$  is the one-third octave band center frequency (Hz),  
 $H_{\text{gap}}$  is the average distance between the payload and the fairing, or cargo bay, wall, and  
 $\text{Vol}_{\text{ratio}}$  is the ratio between the payload volume and the empty fairing, or cargo bay, volume for the payload zone of interest.

This fill-factor is added to the empty fairing expected or test levels. However, engineering judgment must be used in the application of this fill-factor for irregular shaped payloads. Also, Many acoustic specifications are now provided with some fill-factor included.

As an example, assume a cylindrical payload section of radius  $R_s$  in a fairing of radius  $R_f$  shown in Figure A-1.

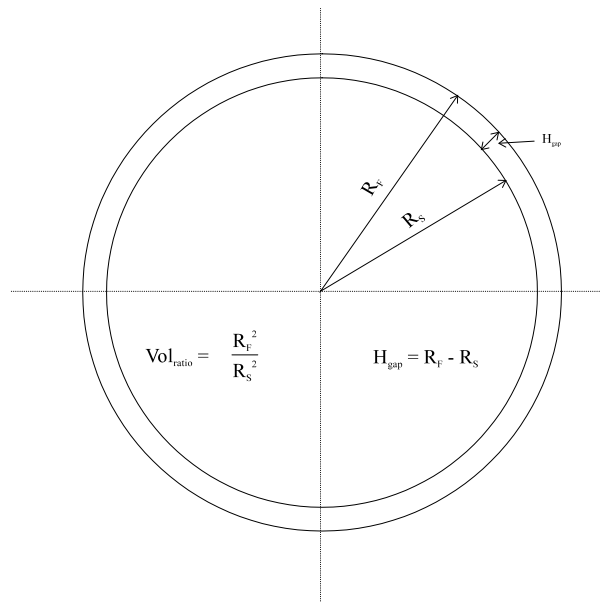

Figure A-1 - Cylindrical Payload in Fairing Acoustic Fill-Factor

Check the GSFC Technical Standards Program website at <http://standards.gsfc.nasa.gov> or contact the Executive Secretary for the GSFC Technical Standards Program to verify that this is the correct version prior to use.

The fill-factor to be added to the empty fairing acoustic levels for various size payloads, assuming a fairing diameter of 3.0 meters, is given in Table A-1, and is shown in Figure A-2.

Table A-1  
Acoustic Fill-Factor (dB)  
3 meter Payload Fairing

1/3 Octave Band Center Freq. (Hz)	Payload Diameter (meters)/Volume Fill Ratio (%)				
	2.85/90.3	2.75/84.0	2.50/69.4	2.25/56.3	2.00/44.4
25	9.7	7.6	4.8	3.3	2.3
32	9.6	7.5	4.7	3.2	2.3
40	9.5	7.4	4.6	3.2	2.2
50	9.3	7.2	4.5	3.1	2.1
63	9.2	7.1	4.4	3.0	2.0
80	8.9	6.9	4.2	2.8	1.9
100	8.7	6.6	4.0	2.7	1.8
125	8.4	6.4	3.8	2.5	1.7
160	8.1	6.1	3.6	2.3	1.6
200	7.7	5.7	3.4	2.2	1.4
250	7.3	5.4	3.1	2.0	1.3
315	6.9	5.0	2.8	1.8	1.1
400	6.4	4.6	2.5	1.6	1.0
500	5.9	4.2	2.2	1.4	0.9
630	5.3	3.7	2.0	1.2	0.7
800	4.8	3.3	1.7	1.0	0.6
1000	4.3	2.9	1.4	0.8	0.5
1250	3.8	2.5	1.2	0.7	0.4
1600	.0.	2.1	1.0	0.6	0.4
2000	2.9	1.8	0.9	0.5	0.3
2500	2.5	1.5	0.7	0.4	0.2
3150	2.1	1.3	0.6	0.3	0.2
4000	1.7	1.1	0.5	0.3	0.2
5000	1.5	0.9	0.4	0.2	0.1
6300	1.2	0.7	0.3	0.2	0.1
8000	1.0	0.6	0.2	0.1	0.1
10000	0.8	0.5	0.2	0.1	0.1

Check the GSFC Technical Standards Program website at <http://standards.gsfc.nasa.gov> or contact the Executive Secretary for the GSFC Technical Standards Program to verify that this is the correct version prior to use.

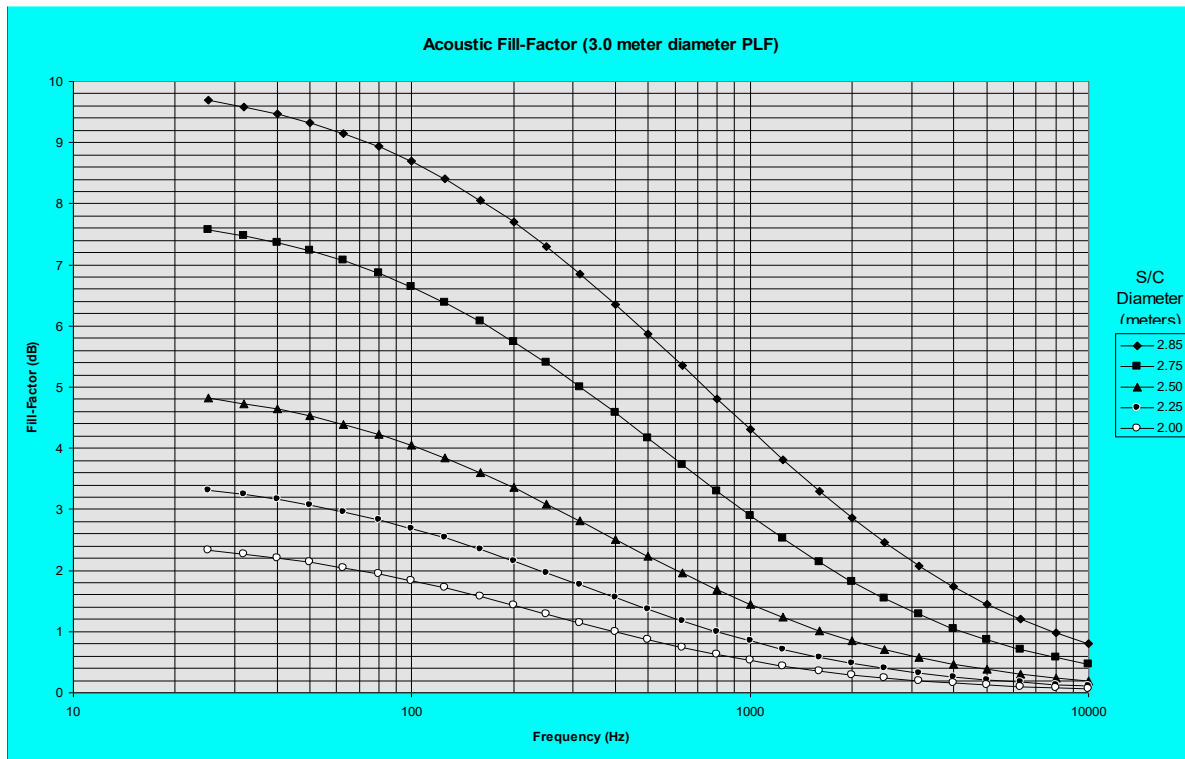

Figure A-2 - Acoustic Fill-Factor for various size Payloads in a 3 meter Diameter Payload Fairing

Additional methods for determining vibroacoustic loads can be found in Dynamic Environmental Criteria NASA Technical Handbook, NASA-HDBK-7005.

### Component Random Vibration

Component random vibration testing is one of the primary workmanship tests to uncover flaws or defects in materials and production. To the greatest extent possible, test levels should be based on knowledge of the expected environment from previous missions or tests. However, it is important to test with sufficient amplitude to uncover the defects. Therefore, as a rule, the input levels should always be greater than or equal to workmanship test levels for electronic, electrical, or electro-mechanical components. If the hardware contains delicate optics, detectors, sensors, etc., which could be damaged by the levels of the workmanship test in certain frequency bands, the test levels may, with project concurrence, be reduced in those frequency regions. A force-limiting control strategy is recommended. The control method should be described in the Verification Test Procedure and approved by the GSFC project.

The qualification (prototype or protoflight) test level is generally 3 dB greater than the maximum expected (acceptance) test level. That is not always the case however. If the expected level is less than the workmanship level an envelope of the two is used to determine the acceptance test level. The qualification level is also an envelope of the maximum expected + 3 dB and the workmanship level. Under this condition, the qualification envelope may not exceed the acceptance level by 3 dB. Figure A-3 demonstrates this.

Check the GSFC Technical Standards Program website at <http://standards.gsfc.nasa.gov> or contact the Executive Secretary for the GSFC Technical Standards Program to verify that this is the correct version prior to use.

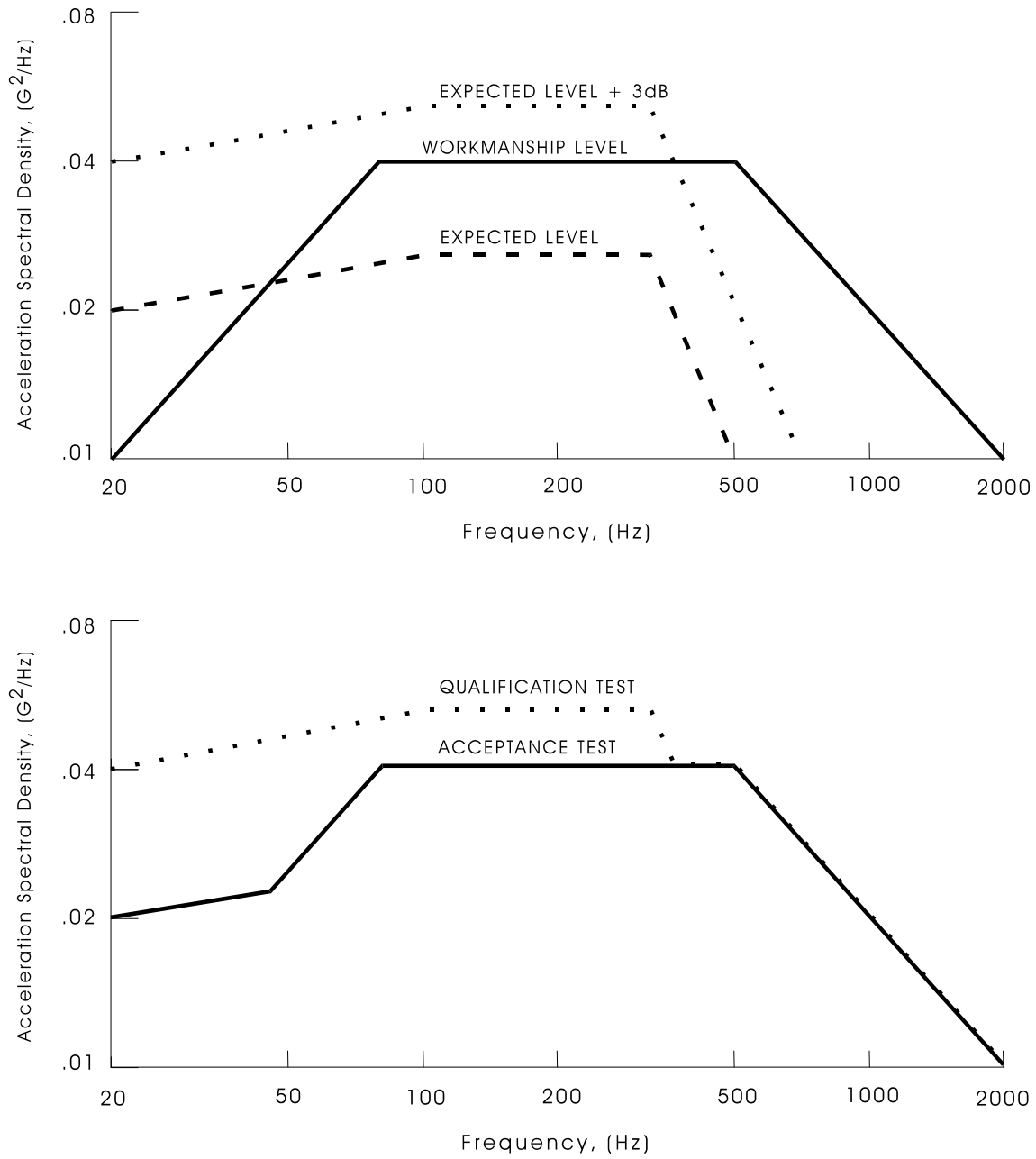

Figure A-3 Determination of Qualification and Acceptance Random Verification Test Levels

Check the GSFC Technical Standards Program website at <http://standards.gsfc.nasa.gov> or contact the Executive Secretary for the GSFC Technical Standards Program to verify that this is the correct version prior to use.

## Mechanical Shock

The maximum shock producing event for payloads is generally the actuation of separation devices. The expected shock environment should be assessed for the device to be used, and a spacecraft separation test should be performed if pyrotechnic devices are to be used for the separation.

A pyrotechnic shock environment is characterized as a high intensity, high frequency, and very short duration acceleration time history that resembles a summation of decaying sinusoids with very rapid rise times. In addition, it is characterized most realistically as a traveling wave response phenomenon rather than as a classical standing wave response of vibration modes. Typically, at or very near the source, the acceleration time history can have levels in the thousands of g's, have a primary frequency content from 1 kHz to 10 kHz, and decay within 3-15 milliseconds. When assessing the source pyro shock environment descriptor as given in the GEVS, the following three factors must be considered:

- a. Because of the very complex waveform and very short duration of the time history, there is no accepted way for giving a unique, "explicit" description of the environment for test specification purposes. The accepted standard non-unique, "implicit" description is a "damage potential" measure produced by computing the Shock Response Spectrum (SRS) of the actual environment time history. A SRS is defined as the maximum absolute acceleration response, to the environment time history, of a series of damped, single-degree-of-freedom oscillators that have a specified range of resonant frequencies and a constant value of viscous damping (e.g.,  $Q=10$ ). This type of descriptor is contained in the GEVS. The resulting fundamental objective of the verification test is to create a test environment forcing time history that has nearly the same SRS as the test specification and thereby give some assurance that the test environment has approximately the same "damage potential" as the actual environment.
- b. Because of the high frequency, traveling wave response like nature of the subject environment, the acceleration level will be rapidly attenuated as a function of distance from the source and as the response wave traverses discontinuities produced by joints and interfaces.
- c. Because of the high frequency, short duration nature of the pyro-shock environment, "potential for damage" is essentially restricted to portions of the payload, or instrument that, for example, have very high frequency resonances (i.e., electrical/electronic elements such as relays, circuit boards, computer memory, etc.) and have high frequency sensitive electromechanical elements such as gyros, etc.

An Aerospace Systems Pyrotechnic Shock study was performed for GSFC and a report was generated in 1970 entitled Aerospace Systems Pyrotechnic Shock Data, NASA Contractor Report-116437, -116450, -116401, -116402, -116403, -116406, and -116019, Vol. I-VII. (Additional information and references can be found in Pyroshock Test Criteria NASA Technical Standard NASA-STD-7003). The following information, extracted from the 1970 final report of this study, is provided to aid in assessing expected shock levels. The results are empirical and based on a limited amount of data, but provide insight into the characteristics of the shock response spectrum (SRS) produced by various sources, and the attenuation of the shock through various structural elements.

The study evaluated the shock produced by four general types of pyrotechnic devices

- Linear charges (MDF and FLSC);
- Separation nuts and explosive bolts;
- Pin-puller and pin-pushers;
- Bolt-cutters, pin-cutters and cable-cutters

Check the GSFC Technical Standards Program website at <http://standards.gsfc.nasa.gov> or contact the Executive Secretary for the GSFC Technical Standards Program to verify that this is the correct version prior to use.

Empirically derived expected SRS's for these four categories are given in Tables A-4 through A-7. It was found that the low-frequency region could be represented, or enveloped, by a constant velocity curve. All shock response curves are for a  $Q=10$ .

The attenuation, as a function of frequency and distance was evaluated for the following general types of structure:

- Cylindrical shell;
- Longeron or stringer of skin/ring- frame structure;
- Ring frame of skin/ring- frame structure;
- Primary truss member;
- Complex airframe;
- Complex equipment mounting structure;
- Honeycomb structure.

It was found that the attenuation of the Shock, as a function of distance from the source, could be separated into two parts; the attenuation of the low-frequency constant velocity curve, and the attenuation of the high-frequency peak levels. The attenuation of the constant velocity curve was roughly the same for all types of structure; whereas the attenuation of the higher frequency peak shock response was different for the various categories of structure. Figure A-8 gives the attenuation of the constant velocity portion of the SRS as a function of distance, and Figure A-9 gives the attenuation of the peak SRS level as a function of distance for the various general categories of structure. It must be emphasized that this information was derived empirically from a limited set of shock data.

As an example of the use of these attenuation curves, assume that the source spectrum is that for an explosive bolt given in Figure A-5, and that an estimate of the shock levels 80 inches from the source is being evaluated for complex equipment mounting structure. From Figure A-8, the constant velocity, low-frequency envelope will be attenuated to approximately 20% of the original level. From Figure A-9, the peak level will be attenuated to approximately 7.8% of the original level. The assumed source spectrum and new estimate of the SRS envelope is shown in Figure A-10.

Structural interfaces can attenuate a shock pulse; guideline levels of reduction are as follows:

Interface	Percent Reduction
Solid Joint	0
Riveted butt joint	0
Matched angle joint	30-60
Solid joint with layer of different material in joint	0-30

The attenuation due to joints and interfaces is assumed for the first three joints.

A reduction of shock levels can also be expected from intervening structure in a shell type structure. An example is shown in Figure A-11.

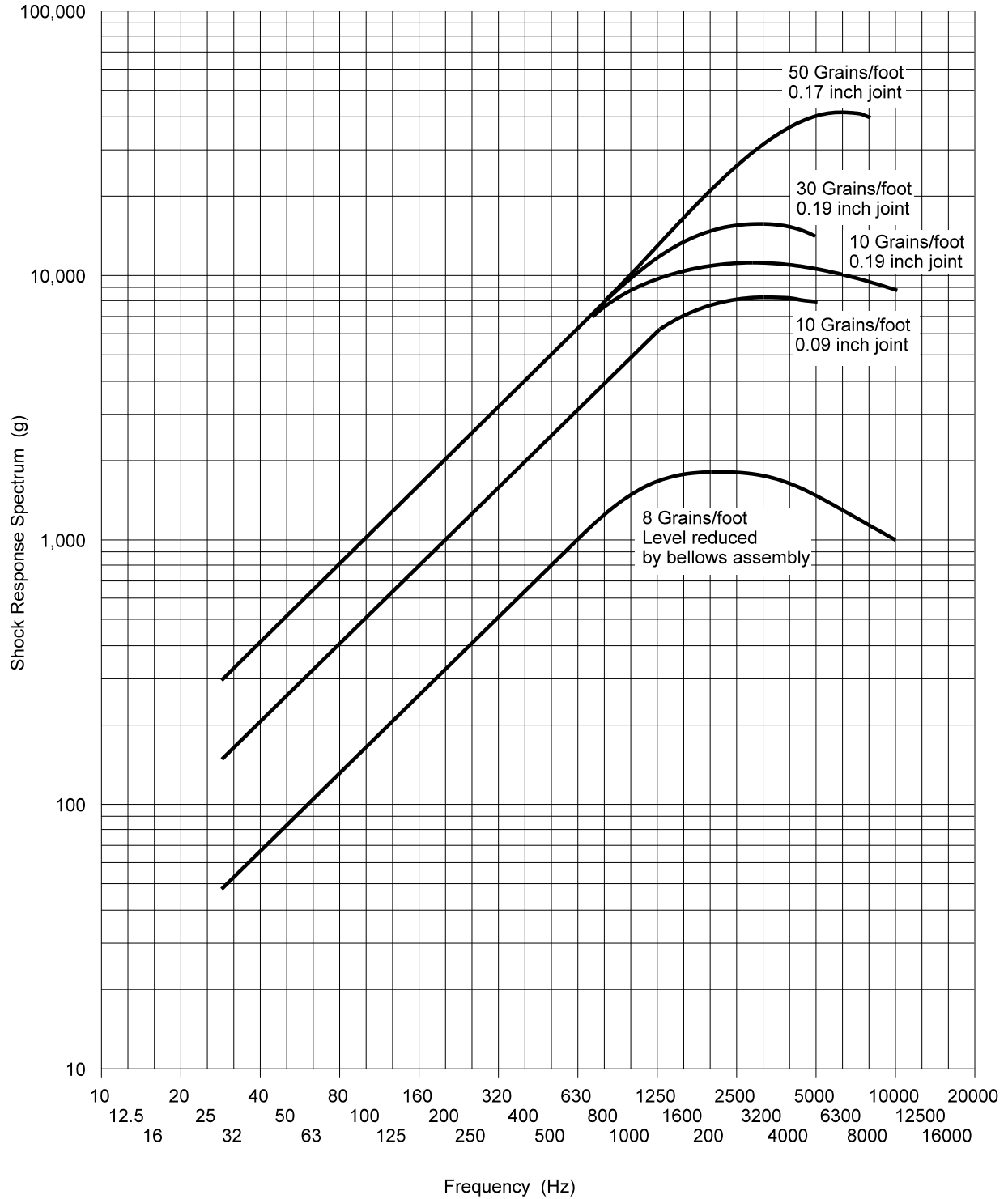

Figure A-4 - Shock Environment Produced by Linear Pyrotechnic Devices

Check the GSFC Technical Standards Program website at <http://standards.gsfc.nasa.gov> or contact the Executive Secretary for the GSFC Technical Standards Program to verify that this is the correct version prior to use.

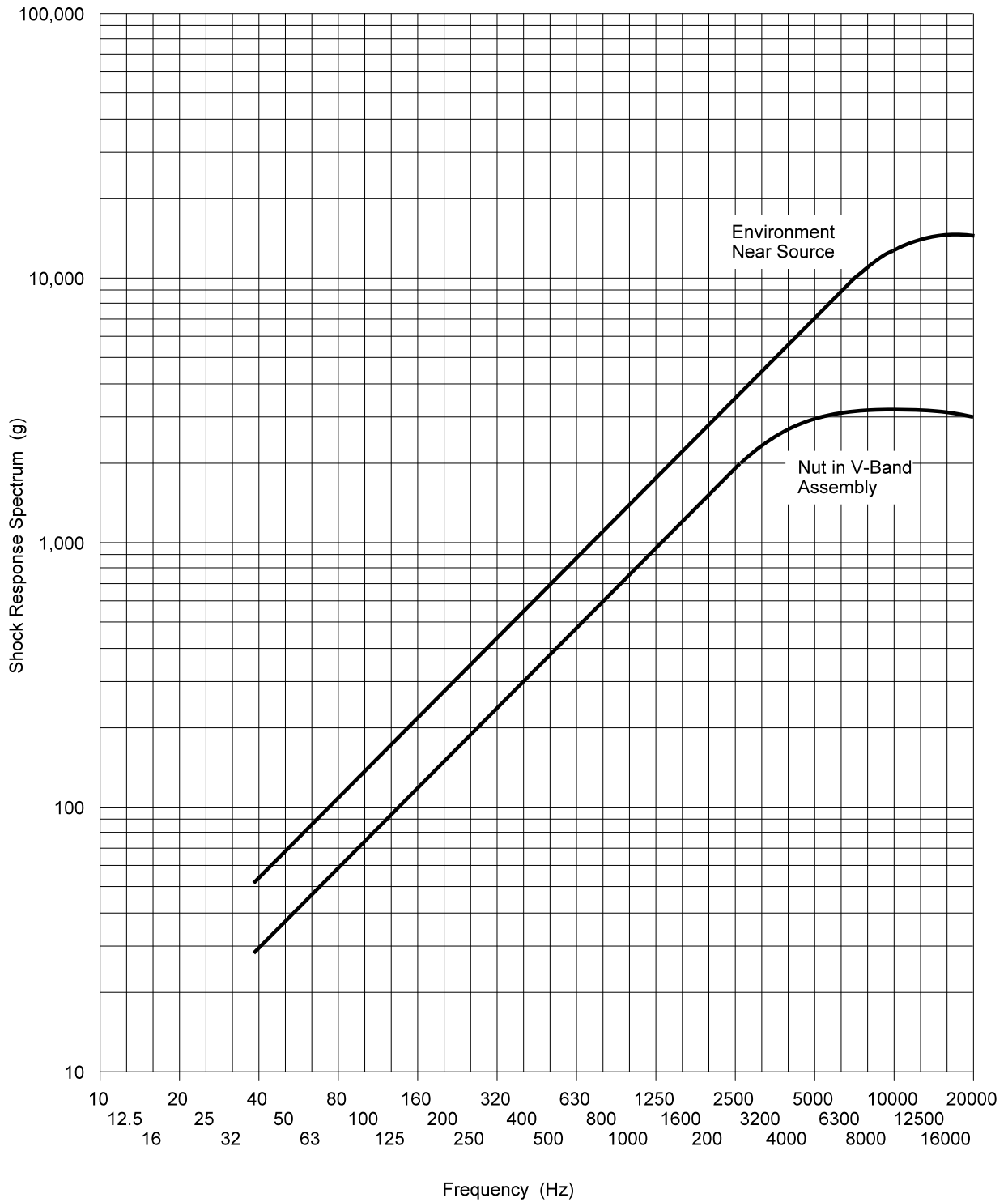

Figure A-5 - Shock Environment Produced by Separation Nuts and Explosive Bolts

Check the GSFC Technical Standards Program website at <http://standards.gsfc.nasa.gov> or contact the Executive Secretary for the GSFC Technical Standards Program to verify that this is the correct version prior to use.

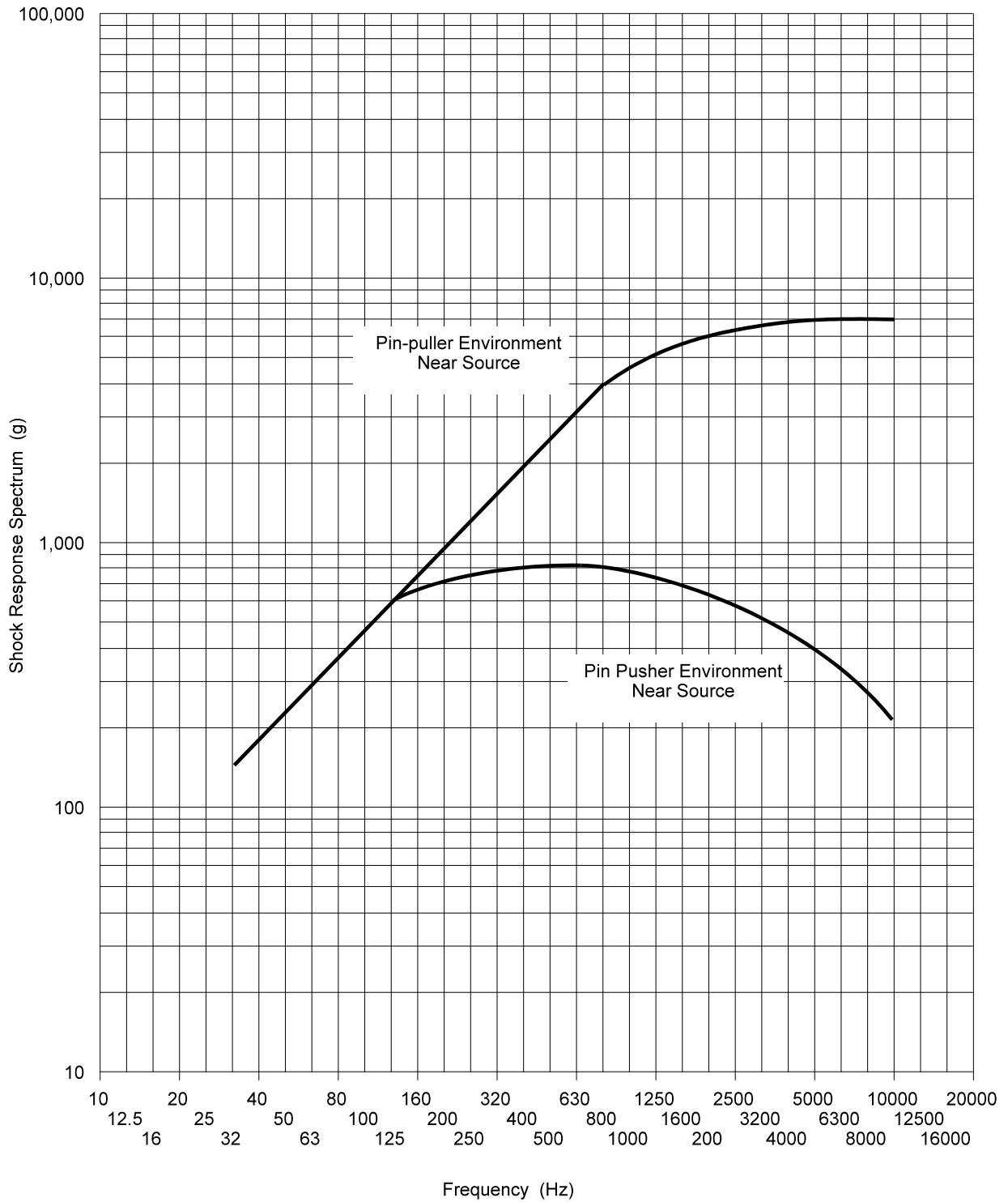

Figure A-6 - Shock Environment Produced by Pin-Pullers and Pin-Pushers

Check the GSFC Technical Standards Program website at <http://standards.gsfc.nasa.gov> or contact the Executive Secretary for the GSFC Technical Standards Program to verify that this is the correct version prior to use.

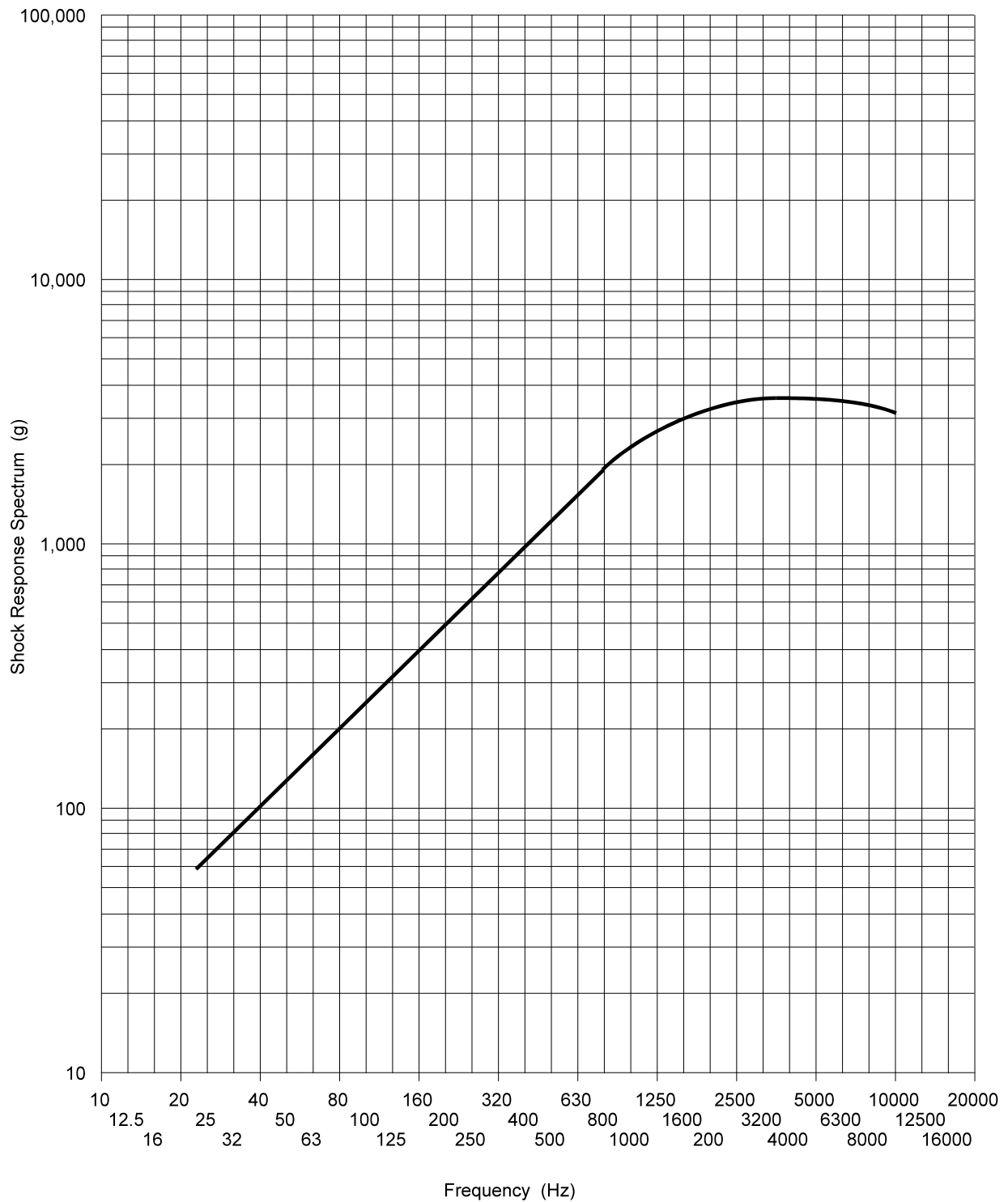

Figure A-7 - Shock Environment Produced by Bolt-Cutters, Pin-Cutters, and Cable-Cutters

Check the GSFC Technical Standards Program website at <http://standards.gsfc.nasa.gov> or contact the Executive Secretary for the GSFC Technical Standards Program to verify that this is the correct version prior to use.

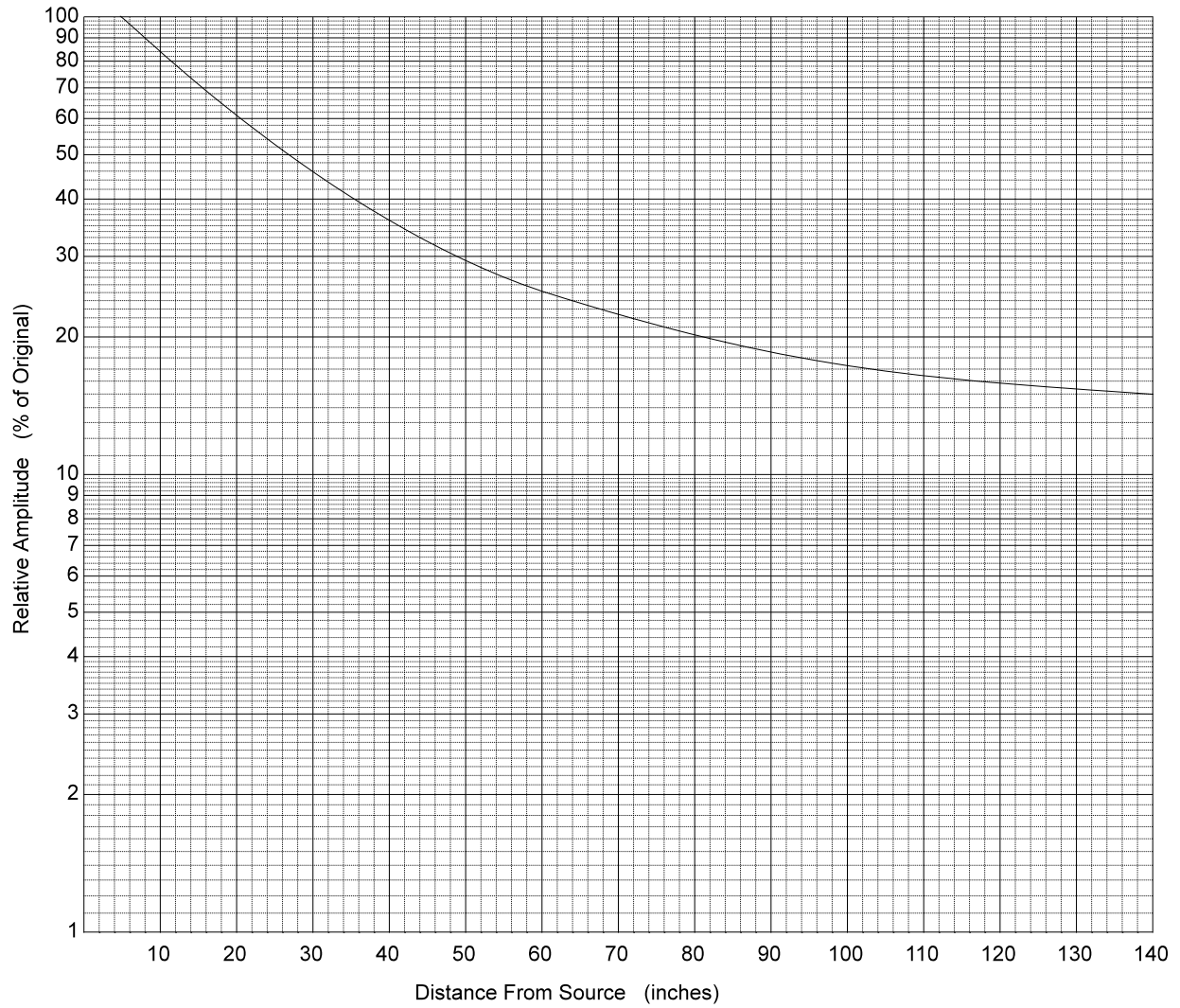
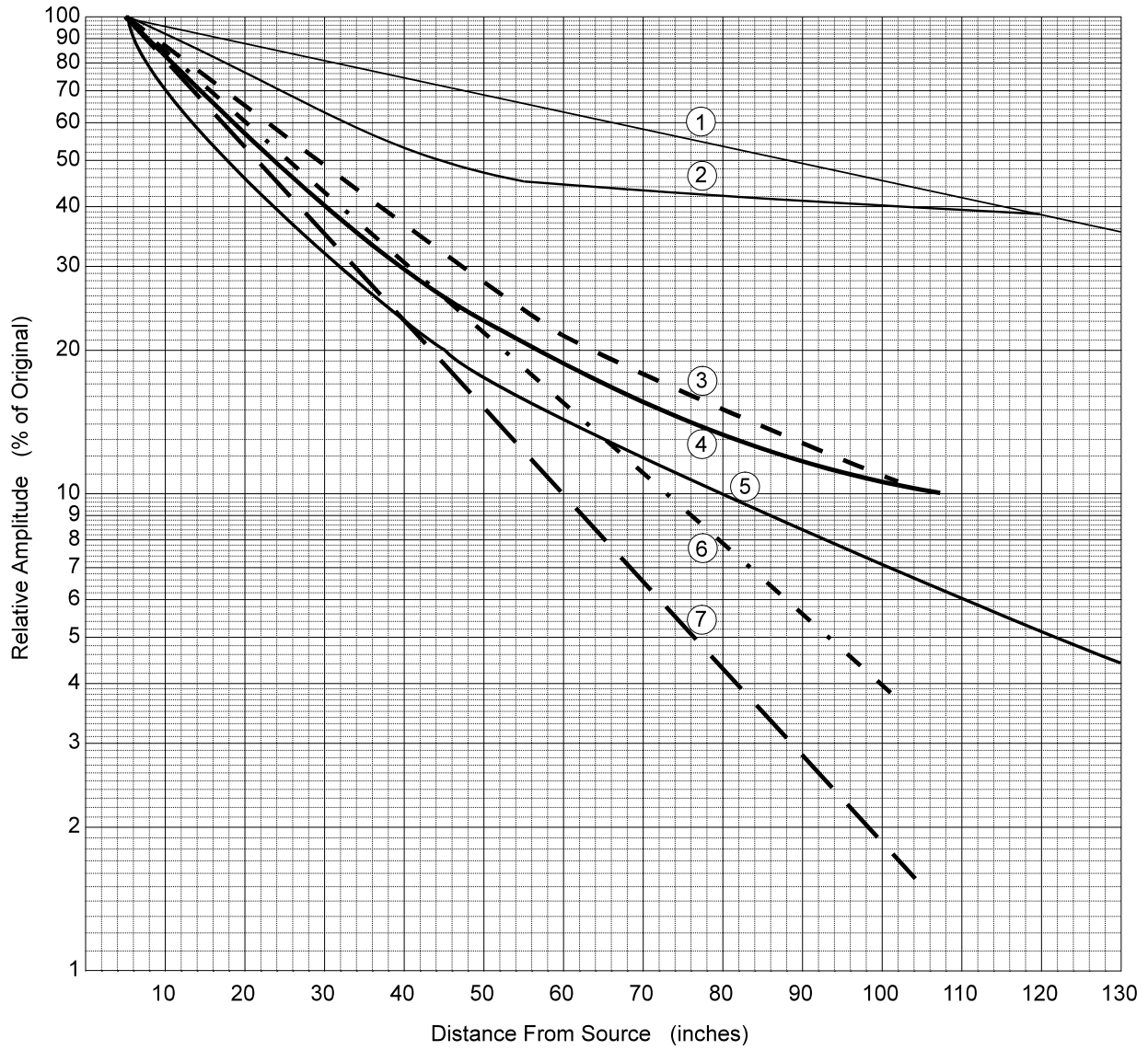

Figure A-8 - Attenuation of Constant Velocity Line

Check the GSFC Technical Standards Program website at <http://standards.gsfc.nasa.gov> or contact the Executive Secretary for the GSFC Technical Standards Program to verify that this is the correct version prior to use.



- ☐ Honeycomb structure
- ☐ Longeron or stringer of skin/ring-frame structure
- ☐ Primary truss members
- ☐ Cylindrical shell
- ☐ Ring frame of skin/ring-frame structure
- ☐ Complex equipment mounting structure
- ☐ Complex airframe

Figure A-9 - Peak Pyrotechnic Shock Response vs Distance

Check the GSFC Technical Standards Program website at <http://standards.gsfc.nasa.gov> or contact the Executive Secretary for the GSFC Technical Standards Program to verify that this is the correct version prior to use.

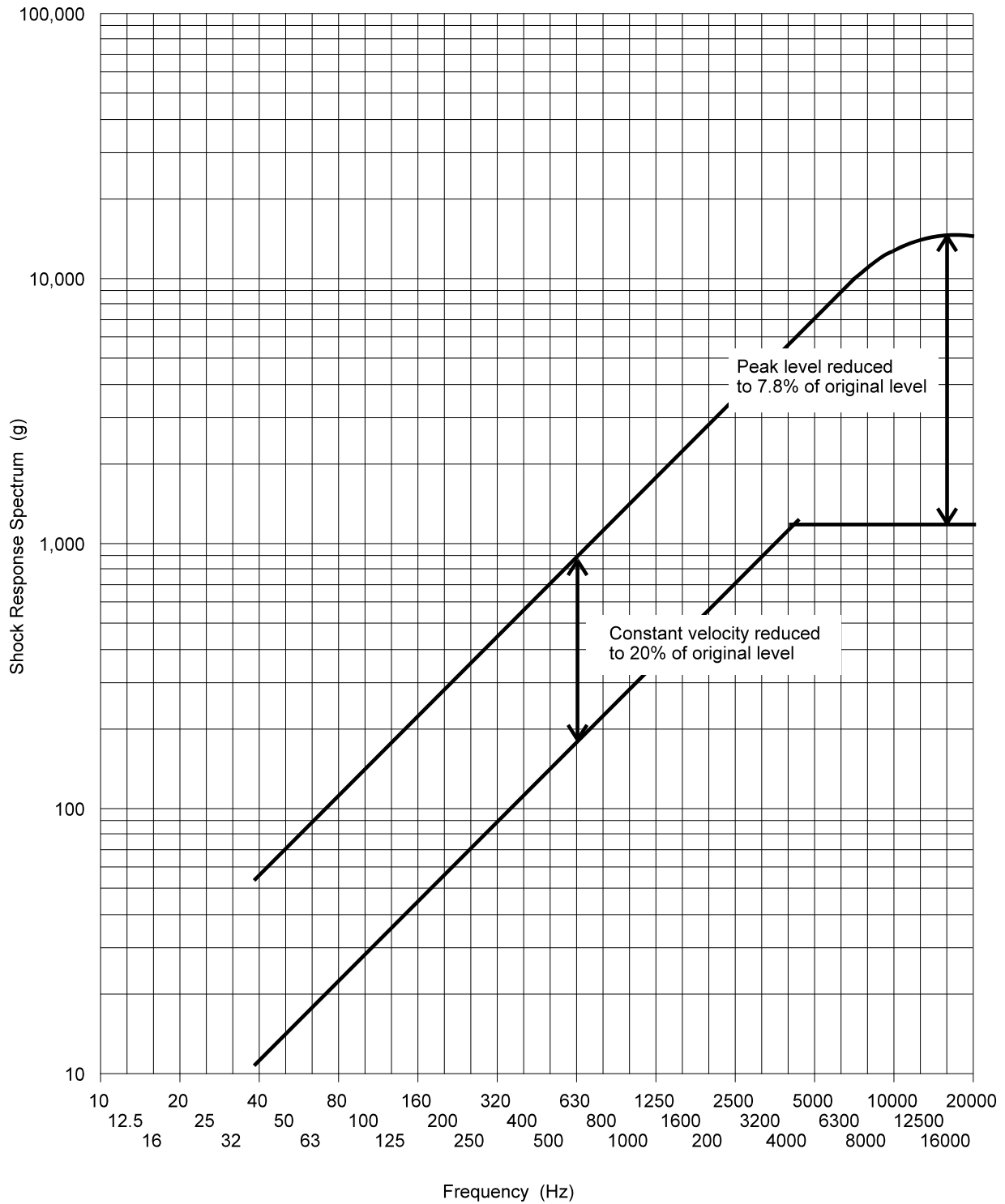

Figure A-10 - Shock Attenuation Example

Check the GSFC Technical Standards Program website at <http://standards.gsfc.nasa.gov> or contact the Executive Secretary for the GSFC Technical Standards Program to verify that this is the correct version prior to use.

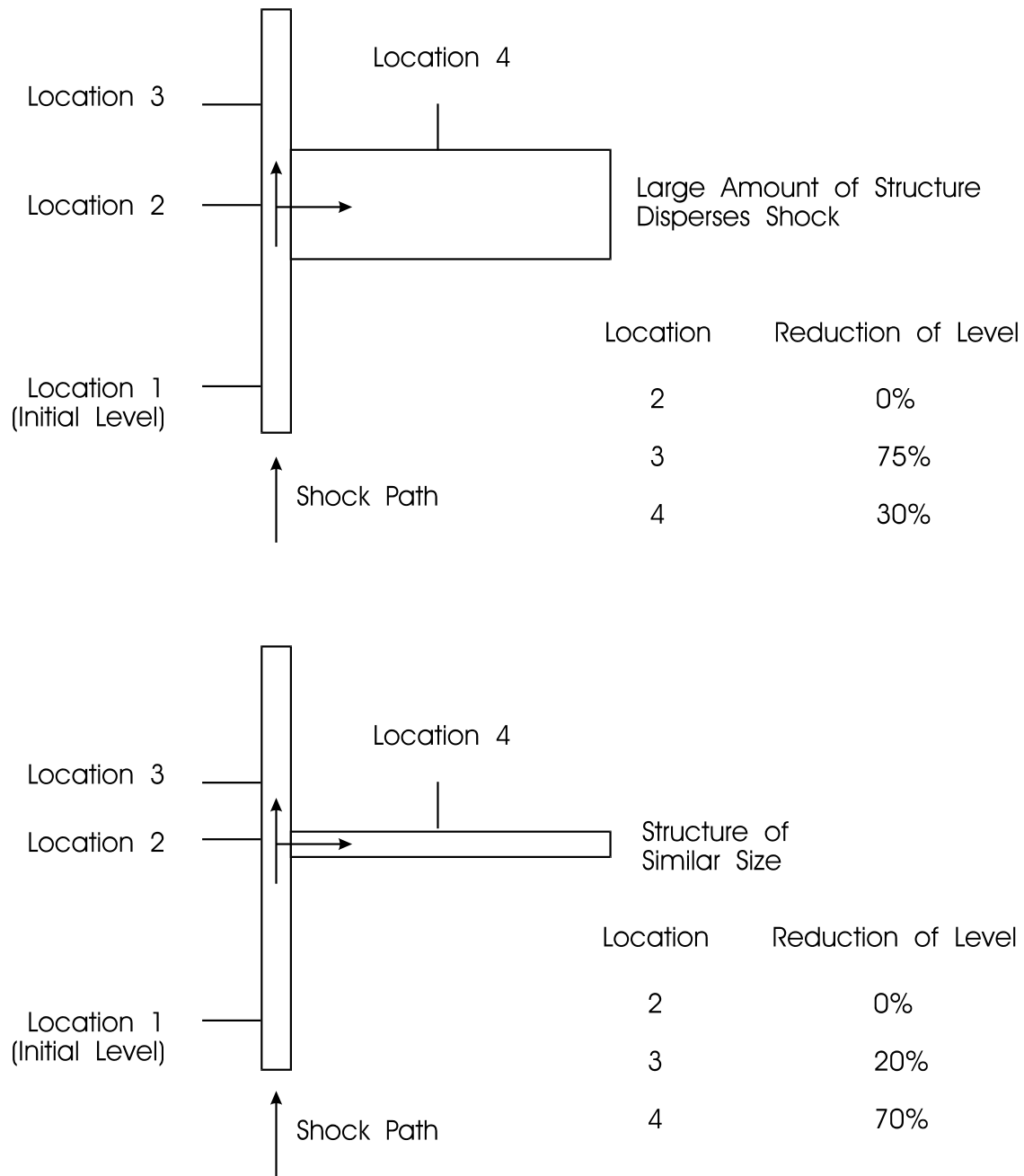

Figure A-11 - Reduction of Pyrotechnic Shock Response due to Intervening Structure

## Appendix B

### Guidelines For CubeSats

**Appendix B - Environmental Verification for CubeSats**  
**Companion to GSFC-STD-7000 (General Environmental Verification Standard)**

David Everett and Leslie Hartz

with inputs from Scott Glubke, Scott Gordon, Eric Grob, Randy Hedgeland, Ken Javor, John McCloskey,  
Carlton Peters, and Tim Trenkle

May 17, 2018

This document describes the risks retired with the verifications described in the General Environmental Verification Standard (GEVS) for GSFC Flight Programs and Projects (GSFC-STD-7000), with the focus on projects such as cubesats, where limited resources and relatively high risk tolerance will lead projects to reduce the scope of testing. This document will enable these projects to more effectively trade cost vs. technical risk when they are developing their verification plans.

This section directly references specific GEVS sections above.

**Section 2.2** of GEVS provides general guidance on environmental verification.

**Section 2.2.2 Verification Program Tailoring**

This section is particularly applicable to cubesats, since a full, GEVS-defined approach would be overkill for a cubesat. GEVS is “written assuming a low-risk program.”

**Section 2.3 Electrical Function Test Requirements**

**Section 2.3.1 Electrical Interface Tests**

This section describes the importance of verifying interfaces prior to connecting electronics. These tests are commonly referred to as safe-to-mate tests. Thorough safe-to-mate tests take some time to plan out and execute, but they prevent damage caused by errors in electrical interfaces. A knowledgeable engineer must determine the resistances and signal levels expected on each pin of an electrical interface, determine the proper test equipment (the wrong meter can cause damage in some cases), and capture that information in a procedure. These measurements are then made with a break-out box prior to integration. For interfaces with many signals, these tests frequently catch mistakes in pin assignments or errors in harness wiring. These tests also catch errors in signal waveforms caused by mistakes or misunderstandings in the design or assembly errors.

This section of GEVS does not mention interfaces tests prior to flight integration, but, in general, ALL projects should plan to conduct interface tests as soon as breadboard designs exist, per GSFC-STD-1000, rule 1.44. These tests will identify mistakes and misunderstandings at a time when the problems can be fixed with little or no schedule and cost impact.

**2.3.2 Comprehensive Performance Test (CPT)**

All projects should follow the principles described here, although what is considered “comprehensive” will certainly be much less for a cubesat than a larger mission. CPT’s are generally run once before environmental testing as a baseline, once spread out over the hot environmental testing, once spread out over the cold environmental testing, and once at the end of environmental testing. It may not be possible to cover all items in the CPT during the hot and cold testing. For cubesats, the project may need to further descope some aspects of the standard CPT testing, based on the costs of the test relative to the risks retired by the testing.

**2.3.3 Limited Performance Tests (LPT)**

Limited Performance Tests are frequently called “functional” tests. For a cubesat, the CPT may be short enough that no LPT is necessary. The primary purpose of the LPT is to ensure nothing has broken during environmental testing. With large spacecraft, the CPT is too long to execute multiple times during environmental testing.

### **2.3.4 Performance Operating Time and Failure-Free Performance Testing**

GOLD rule 2.01 in GSFC-STD-1000 duplicates the requirements associated with this section of GEVS, but it allows fewer than 1000 operating hours for missions which are class D and below.

Operating hours as a system provides a higher likelihood that rare timing problems will manifest themselves. Total component operating hours on the ground help screen out early failures related to manufacturing defects and design errors. Hours in vacuum are generally more stressful on components, especially at hot temperature, because there is no convection to cool the parts. In general, the more operating hours the better, to identify problems.

Cubesat projects should investigate alternative testing options, such as a 500-hour burn-in at elevated temperature, which can provide screening for a variety of parts, design, and workmanship issues. The duration of a cubesat mission should be factored in to the considerations related to operating time and failure-free performance testing.

## **2.4 Structural and Mechanical Verification Requirements**

It is of utmost importance to ensure that the cubesat hardware poses no risks to any primary payload with which it is manifested. The second consideration should be to reduce the risk of structural and mechanical failure of the cubesat as much as possible given the programmatic constraints that cubesats usually face.

Given the constrained resources of most cubesat programs, a structural qualification unit is not likely. Most cubesat projects that are launching a single cubesat will want to follow a protoflight model for structural verification. Missions with multiple identical cubesats will want to consider protoflight testing for the first unit with acceptance testing for the follow on units.

The baseline structural and mechanical verification program defined in GEVS assumes that a payload is sufficiently modularized to allow for testing lower levels of assembly. For cubesats this is typically not the case, so mechanical verification testing will almost always be performed at the payload level on the cubesat mounted in its dispenser system. Verification tests defined in GEVS for lower levels of assembly should be addressed as required during cubesat testing.

### **2.4.1 Structural Loads Qualification**

Qualification of the cubesat for its structural loads environment will be accomplished by a combination of test and analysis. Structural loads qualification is typically performed by test and accompanied by analysis showing positive margins of safety against limits loads using the factors defined in Table 2.2-3 in GEVS. For metallic structure, it may be possible to demonstrate strength qualification by analysis only using higher no-test factors of safety.

Determining the structural loading environment for cubesats will depend on a number of factors including the first frequency of the cubesat-dispenser system and whether or not a vibration isolation system is used. For larger payloads, a coupled loads analysis (CLA) is used to derive the quasi-static limit loads for structural loads verification. Since most cubesats do not respond dynamically to the low-frequency launch environment, a dedicated CLA will not be run to derive launch loads. The cubesats will be analyzed and tested for a set of conservative quasi-static limit loads that have been developed to envelope the expected loads for a given launch configuration. If the first frequency of the combined cubesat-dispenser (and possible load isolation system) falls below 100 Hz, a model of the cubesat system might need to be provided to the launch vehicle provider for inclusion in the coupled loads analysis to derive limit loads for structural qualification. Cubesat systems with modes below 100 Hz may also need to provide a test verified model that has been correlated through a modal survey or vibration testing

Whenever possible, structural testing of the cubesat should be performed inside its dispenser or an identical substitute. This ensures that the interfaces and loads on the cubesat are as flight like as possible. In addition, the rail-style dispenser can result in rattling of the cubesat, which results in non-linear response, which can only be simulated by test. Tests should be performed in each of three orthogonal axes.

#### **2.4.1.1 Coupled Loads Analysis**

Given the late manifesting, high frequency and low mass nature of cubesats, a formal couple loads analysis is unlikely to be possible for most cubesat programs. When developing the structural loads for a cubesat, the mechanical experts should try to envelop the structural loads from all possible launch services.

Check the GSFC Technical Standards Program website at <http://standards.gsfc.nasa.gov> or contact the Executive Secretary for the GSFC Technical Standards Program to verify that this is the correct version prior to use.

#### **2.4.1.2 Modal Survey – Frequency Verification**

Because of their low mass, high frequency and simple mode shapes, a dedicated modal survey test of the cubesat-dispenser system is generally not necessary. Usually a test verified model would only be required if the cubesat or cubesat-deployer system has modes below 100 Hz. If a test-verified model of the cubesat-dispenser system is required, the correlation can usually be performed based on measured responses from vibration testing that can be used to tune the finite-element model so that it accurately represent the frequency and response amplitudes from the test. In most cases, if a test verified model is not required, a low-level signature test (sine or random) in each axis is sufficient to verify the first frequency of the cubesat system. A low-level signature test is generally performed before and after vibration testing to ensure that the structural characteristics of the system have not changed after exposure to the vibration environment.

#### **2.4.1.3 Design Strength Qualification**

Strength qualification of cubesats can be accomplished in a number of ways. First, if the random vibration (or sine vibration, if required) environment is the enveloping source of structural loads, the vibration test can serve as the strength qualification test. Care should be taken when using this approach to ensure that realistic analytical assumptions for damping and load paths are used to determine loading under dynamic vibration.

If vibration cannot be shown to be the driving environment for structural loads and the cubesat has simple, easy-to-analyze load paths, strength verification can be accomplished through analysis only using no-test factors of safety as outlined in this section of GEVS. It should be noted that a no-test approach is only applicable to metallic structures and cannot be used for beryllium, welded, ceramic, composite, or bonded structures.

If vibration testing or a no-test analytical approach cannot be shown to be adequate to demonstrate structural qualification, the project should perform a dedicated strength test.

#### **2.4.1.4 Structural Reliability (Residual Strength Verification)**

Cubesat projects should assess the structural risks associated with using materials not in table 1 of MSFC-SPEC-3029. The risks will be primarily related to mission success, since the launch container provides protection to the primary payload.

#### **2.4.1.5 Acceptance Requirements for Strength Qualification**

This section applies to all cubesats. Strength testing is generally not required for a follow-on cubesat whose design has been previously demonstrated to be strength qualified except for structures using materials that have been identified as requiring proof testing.

#### **2.4.2 Vibroacoustic Qualification**

Random vibration, without acoustics testing, is generally sufficient for cubesats. Cubesats do not have large surface areas that can absorb acoustic energy, and the stiffness of most dispensers provides additional protection. Random vibration is likely to be the most important mechanical environments test for most cubesats. It is the primary structural loading environment for cubesats with a first frequency greater than 100 Hz. It is also an excellent workmanship test. This test alone may be sufficient for a cubesat.

Force limiting will generally NOT be useful for cubesats because of their low mass, but special circumstances may make the extra complexity of force limiting worth the effort (for instance, an interface with high random environment but not much mass available to deliver energy to the cubesat or a cubesat deployer on an isolation system with high mass participation modes that would result in unrealistic loading during vibration testing).

#### **2.4.2.3 Payload Random Vibration Qualification Tests**

Whenever possible, vibration testing of the cubesat should be performed inside its dispenser or an identical substitute. This ensures that the interfaces and loads on the cubesat are as flight like as possible. Cubesats typically do not have levels of assembly below the payload level. Therefore, all vibration testing is performed at the payload level of assembly. However, the requirement to expose electrical, electronic, and electro-mechanical hardware to minimum workmanship levels should be maintained for cubesats as a

Check the GSFC Technical Standards Program website at <http://standards.gsfc.nasa.gov> or contact the Executive Secretary for the GSFC Technical Standards Program to verify that this is the correct version prior to use.

screen for workmanship flaws in electronics boards. The cubesat protoflight vibration environment should therefore be derived as the envelope of limit level + 3dB and minimum workmanship.

#### **Section 2.4.2.5 Component/Unit Vibroacoustic Qualification**

This section is not typically applicable to cubesats as all verification testing will be performed at the payload level of assembly.

As part of payload level of assembly testing, vibration testing of the CubeSat inside the dispenser typically requires demonstration of no power on until released from the dispenser, and no RF emissions until after thirty minutes after release from the dispenser.

#### **Section 2.4.2.8 Retest of Reworked Hardware**

This section provides guidance on testing after rework.

#### **2.4.3 Sinusoidal Sweep Vibration Qualification**

Because of the higher resonant frequencies in a small cubesat, a sinusoidal sweep is generally NOT required. A sine test would only be required if the resonant frequency of the cubesat is less than 1.5 times the upper frequency defined for the launch vehicle sine environment. A mechanical engineer should verify this assumption for all cubesats.

A sine vibration test should also be considered if cubesat uses a rail-style dispenser or a load isolation system. The rail-style dispenser system can cause non-linear responses due to rattling under the low-frequency dynamic launch environment simulated by sinusoidal vibration. The load isolation system may drop the frequency of the system to where it could respond to a sine input.

Whenever possible, sine vibration testing of the cubesat should be performed inside its dispenser or an identical substitute. This ensures that the interfaces and loads on the cubesat are as flight like as possible. Vibration testing of the cubesat inside the dispenser typically requires demonstration of no power on until released from the dispenser (i.e., now vibe-induced power on) and no RF emissions until after 30 minutes after release from the dispenser.

#### **2.4.4 Mechanical Shock Environment**

Self-induced and externally induced shock should be considered when assessing the cubesat for sensitivity to the shock environment. Release from the launch container will provide an external shock to a cubesat. Launch vehicle separation events are also sources of external shock for cubesat payloads. However, the interfaces between launch vehicle shock sources and the launch container plus the interface between the container and the cubesat will help reduce the severity of the launch vehicle shock environment. All external shock sources for the cubesat should be captured in interface requirements from the container manufacturer or the launch provider.

Cubesat designers also need to consider internal sources of shock from deployments (both the release and the hard stop of any undamped release) of on-board mechanisms and from any other sudden release of stored energy that will occur during operation of the payload.

##### **2.4.4.1 Subsystem Mechanical Shock Tests**

This section provides guidance on testing for shock and for assessing the risk associated with not performing a shock test. The shock verification approach defined in this section is applicable to cubesats.

##### **2.4.4.2 Payload (Spacecraft) Mechanical Shock Tests**

As stated above, the cubesat designer should consider the environment and determine whether or not a system-level test is appropriate.

#### **2.4.5 Mechanical Function Verification**

This section provides guidance on verification of mechanisms, including life tests and torque margin. Some or all of it may be applicable, depending on the type of mechanisms in the system. The primary difference between a cubesat and a large, class B mission may just be in the level of detail in the analyses. Cubesat

Check the GSFC Technical Standards Program website at <http://standards.gsfc.nasa.gov> or contact the Executive Secretary for the GSFC Technical Standards Program to verify that this is the correct version prior to use.

designers should make conservative, simplifying assumptions and move forward, assuming the margin requirements are met. Be aware of forces that become significant for small mechanisms, such as friction, electrostatic force, surface tension, etc., and ensure sufficient force is available to drive the mechanism under all conditions.

During design, consider how the deployments will be tested. Under most cases, the designer should be able to provide enough force and strength to perform deployment tests on the ground without g-negation devices.

#### **2.4.6 Pressure Profile Qualification**

Cubesat designers should ensure adequate venting for the worst-case pressure profile. A good rule of thumb that envelopes all launch vehicles is to provide a vent area of 0.05 square inches (0.25" diameter hole) per cubic foot of enclosed volume. This will ensure that the peak pressure level with the volume is less than 0.5 psi during launch. The small volume of a cubesat limits the concerns associated with pressure profile.

#### **2.4.7 Mass Properties Verification**

As this section states, mass properties verification is dependent on mission requirements.

### **2.5 Electromagnetic Compatibility Requirements**

Given that cubesats typically launch unpowered, the interference to the launch vehicle or from the launch environment is not applicable in most cases. In general, the most significant concerns for cubesats consist of self-compatibility, compatibility with ground-based tracking radars, and compatibility with on-board antenna(s) on-orbit.

GEVS is based primarily on MIL-STD-461, which specifies tests at the component level prior to integration into a larger platform, e.g. instrument, payload, spacecraft, etc. Because cubesats are generally small, self-contained enclosures, the equivalent of a "component level" test program would apply at the card level, for which the tests specified in GEVS are generally not applicable.

This places an emphasis on the need to identify and correct potential issues at the card level to the extent feasible. This may be accomplished with a combination of test and analysis, the specifics of which must be determined by the needs of each platform. A minimum set of recommendations is provided in section 2.5.1 below.

The integrated cubesat platform must demonstrate compatibility with its communications subsystem. A minimum set of recommendations is provided in section 2.5.2 below.

#### **Card Level Tests**

For cards that provide sources of power to other cards, an assessment of power quality should be performed at card level. This may consist of a simple measurement of differential voltage ripple in the time domain (i.e. on an oscilloscope). The voltage ripple limit must be determined by the specific needs of the platform, but a recommended limit is 200 mV peak-to-peak on top of a 12 Vdc bus, measured in the time domain with a bandwidth of 1 MHz.

Most cubesat platforms consist of a single instrument. On such platforms, there are no hard and fast requirements for conducted emissions (CE), conducted susceptibility (CS), or power quality to be applied. Such requirements are intended to establish compatibility between multiple instruments or payloads operating from a common power bus. Thus the main issue regarding power on single instrument cubesats reduces to compatibility between the single instrument and the power subsystem.

On cubesat platforms that include more than one instrument or experiment, measures must be taken to control the ripple generated by any instrument that may be seen by the other instrument(s). This is best done with a measurement of current ripple at card level. The limit must be tailored to each specific platform. A recommended starting point is to characterize the impedance between the power source and the common distribution point. The current limit may be derived from the allowable voltage ripple at the distribution point and the common source impedance, while also allowing for the number of different loads. Because the

Check the GSFC Technical Standards Program website at <http://standards.gsfc.nasa.gov> or contact the Executive Secretary for the GSFC Technical Standards Program to verify that this is the correct version prior to use.

source impedance varies with frequency, the current limit will also vary with frequency. Thus it is recommended that this measurement be performed in the frequency domain with a spectrum analyzer, similar to the CE101 test method of MIL-STD-461G.

Once all of the cards are integrated but prior to closing up the box, a measurement of aggregate time domain differential voltage ripple should be performed at the common distribution point in the power subsystem in order to verify that the voltage ripple requirement above is still met with all of the loads operating. Designers of the system should consider a layout that enables this test.

On cubesat platforms with one or more instruments that are particularly sensitive to magnetic fields (e.g. magnetometers), it may be necessary to apply some limit of magnetic field emissions to other equipment in the system. This may be done at the card level with a tailored version of the RE101 test method of MIL-STD-461G. The ultimate verification will be an assessment of card-to-card compatibility in the integrated configuration.

### Integrated Cubesat Level Tests

At the integrated cubesat level, it must be demonstrated that its radiated emissions do not interfere with the uplink signal(s) to its receiving antenna(s). The recommended method, per MIL-STD-464, is first to connect the output of the receive antenna directly to an external EMI receiver or spectrum analyzer, then measure the received RF power levels at the uplink frequencies while the platform is put through its normal operations. If it is possible to define a limited set of “most emissive modes,” it may be sufficient to test only in those modes, and it will make most efficient use of test time.

A radio frequency (RF) link margin analysis should be performed in order to determine the minimum signal that may be read by the on-board receiver(s). This level is used as the benchmark for the measurement outlined above. Thus the combination of measurement and analysis provides a direct assessment of radio frequency (RF) self-compatibility while also providing an assessment of margin.

Also, the integrated cubesat must demonstrate that it is compatible with the RF energy generated by its transmitter(s) and antenna(s). This may be demonstrated by transmitting the full power levels out of each transmit antenna while the platform is put through its normal operations. If it is possible to define a limited set of “most susceptible modes,” it may be sufficient to test only in those modes, and it will make most efficient use of test time.

## 2.6 Thermal Vacuum

### 2.6.1 Summary of Requirements

Due to the small size and integrated nature of cubesats, the project should determine how much testing is appropriate prior to integration vs. conducting all testing at the system level. Component-level testing reduces the risk that a problem will be found later, after integration. Specifics on thermal vacuum testing:

- **Bakeout:** From a “do no harm” perspective, a system-level bakeout is generally required to ensure the cubesat does not have any outgassing products that might damage the prime payload.
- **Balance:** Thermal balance testing at the system level will demonstrate proper thermal analysis and temperature control.
- **Temperature:** Testing the system over temperature ensures that all components work together as timing and other parameters change over temperature.
- **Cycling:** Thermal cycling stresses components and assemblies to weed out weak designs and workmanship issues. Because of the small size of components and even the entire system, the temperature can generally be cycled fairly quickly, so the cost of performing a cycle is not that great. Other testing, such as a high-temperature burn in, might be considered as an alternate approach to extra cycling.

### 2.6.2 Thermal-Vacuum Qualification

This section, with the margins and cycles, is appropriate for cubesats, with the considerations listed above.

The use of a TQCM is not required if the cubesat can meet the time-at-temperature requirements of bakeout.

It is not necessary for a cubesat to dwell for 24 hours at each extreme. Dwell times should be based on how quickly the spacecraft internal temperatures will stabilize and how long it takes to run performance testing.

Failure-free performance duration of 100 hours hot and 100 hours cold reduces the risk that some vacuum or temperature related problem is missed during the testing. The project should carefully look at the risks vs. benefits of reducing these times.

### **2.6.3 Thermal Balance Qualification**

This section is generally applicable to cubesats.

The survival case for cubesats might be unpowered during launch.

Because of the small size, the cubesat may be more susceptible to heat leaks through cabling and mounting.

### **2.6.4 Temperature-Humidity Verification**

This section is only applicable for components in pressurized volumes.

### **2.6.5 Leakage (Integrity Verification)**

Any components that rely on a pressurized volume should be tested to ensure they do not leak more than is acceptable.

## **2.8 Contamination and Coatings Engineering, and Planetary Protection**

### **2.8.1 Contamination**

This section is applicable to cubesats. The first step is determination of contamination sensitivity. Sensitivity to contamination should be based upon the optical, thermal, and mechanical system performance requirements. Assessments should address all environments including materials outgassing, on-orbit and thermal vacuum molecular transport, particle generation, materials degradation, thruster plume impingement, solar radiation, atomic oxygen, charged particle effects, and any synergistic effects among these environments. The primary payload may drive the contamination control requirements for the cubesat system. For many cubesats, proper material selection and relatively straightforward handling techniques may be sufficient to achieve the necessary contamination control.

### **2.8.2 Coatings Engineering**

This section is applicable to cubesats. Since many cubesats have a short mission duration, the degradation of coatings from beginning of life to end of life will likely be relatively small. GSFC Coatings Committee and thermal engineering experts maintain the latest coatings performance information. Unproven coatings should be reviewed by the GSFC Coatings Committee.

### **2.8.3 Planetary Protection**

Cubesats will be required to comply with planetary protection requirements if they are leaving Earth orbit or going to the moon.

## **2.9 End-to-End Testing**

End-to-end testing per this section of GEVS is applicable to cubesats. It is easy to miss subtle design issues that will cause problems in flight. Compatibility testing and mission simulations provide an inexpensive way to retire these sort of risks.

## **Appendix A**

The acoustic fill information is most likely not useful for a cubesat. The random vibration and shock information might be useful.