

**Measurement System Identification:  
Metric (English)**



**NASA TECHNICAL STANDARD**

**National Aeronautics and Space Administration**

**NASA-STD-8739.5A  
Change 1**

**Approved: 2015-09-14  
Superseding NASA-STD-8739.5**

**WORKMANSHIP STANDARD FOR FIBER OPTIC TERMINATIONS,  
CABLE ASSEMBLIES, AND INSTALLATION**

# NASA-STD-8739.5A

## DOCUMENT HISTORY LOG

Status	Document Revision	Approval Date	Description
Baseline		1998-02-09	Initial Release
Change	1	2008-07-25	Update references, add ‘requirement’ tags, and revalidate (JWL4)
Change	2	2011-03-29	Editorial corrections to Foreword and paragraph 9.2.c. Format Page numbers. Add reference to NASA-STD 8709.22 in paragraphs 2.1.2 and 3.2. (JWL4)
Revision	A	2015-09-15	The Workmanship Standard for Fiber Optic Terminations, Cable Assemblies, and Installation, NASA-STD-8739.5, was revised to: <ul style="list-style-type: none"> <li>a. Reflect current NASA standards formatting</li> <li>b. Update language for seeking relief from the stated requirements</li> <li>c. Make it consistent with NASA-STD-8739.6</li> <li>d. Implement other clarifications and corrections</li> </ul> (JFP)
Change	1	2021-07-09	Revalidated with changes to: <ul style="list-style-type: none"> <li>a. Add Section 2.3 Order of Precedence.</li> <li>b. Apply additional controls to mechanical stripping operations.</li> <li>c. Increase magnification range for inspection of cleaved bare fibers.</li> <li>d. Add controls for cleaning materials</li> <li>e. Remove improper use of term “preconditioning”, where applicable, replacing with “temperature cycling”.</li> <li>f. Require minimum long term bend radius in engineering documentation.</li> <li>g. Change cable tie spacing from recommendation to requirement.</li> </ul>

# NASA-STD-8739.5A

## FOREWORD

This Standard is published by the National Aeronautics and Space Administration (NASA) to provide uniform engineering and technical requirements for processes, procedures, practices, and methods that have been endorsed as standard for NASA programs and projects, including requirements for selection, application, and design criteria of an item.

This Standard is approved for use by NASA Headquarters and NASA Centers, including Component Facilities and Technical and Service Support Centers, and is intended to be applied on NASA contracts.

This Standard prescribes NASA's process and end-item requirements for reliable fiber optic terminations, cables, assemblies, and the installation thereof.

This NASA-STD was developed by NASA Headquarters Office of Safety and Mission Assurance and the NASA Workmanship Standards Program. Requests for information, corrections, or additions to this Standard should be submitted to the National Aeronautics and Space Administration, Director, Safety and Assurance Requirements Division, Office of Safety and Mission Assurance, Washington, DC 20546 or via "Feedback" in the NASA Standards and Technical Assistance Resource Tool at <http://standards.nasa.gov>.

  
Terrence W. Wilcutt  
Chief, Safety and Mission Assurance

  
Approval Date

TABLE OF CONTENTS

**Document History Log ..... 2**  
**Foreword..... 3**  
**Table of Contents ..... 4**  
**List of Appendices..... 5**  
**List of Figures..... 5**

**1. SCOPE ..... 6**  
1.1 Purpose..... 6  
1.2 Applicability ..... 6

**2. APPLICABLE AND REFERENCE DOCUMENTS ..... 7**  
2.1 Applicable Documents..... 7  
2.2 Reference Documents ..... 7  
2.3 Order of Precedence..... 9

**3. ACRONYMS AND DEFINITIONS..... 11**  
3.1 Acronyms and Abbreviations ..... 11  
3.2 Definitions..... 11

**4. GENERAL..... 15**  
4.1 General..... 15  
4.2 Design Considerations ..... 15

**5. TRAINING AND CERTIFICATION PROGRAM..... 17**

**6. FACILITIES, EQUIPMENT AND MATERIALS..... 18**  
6.1 Environmental Conditions ..... 18  
6.2 Tools and Equipment ..... 18  
6.3 Inspection Aids ..... 19  
6.4 Storage and Handling..... 19  
6.5 Parts and Materials Selection..... 19  
6.6 Solvents..... 20  
6.7 Adhesives..... 20  
6.8 Material Shelf Life Requirements..... 22  
6.9 Personnel Protection ..... 22

**7. OPTICAL FIBER END PREPARATION ..... 24**  
7.1 General..... 24  
7.2 Safety Requirements ..... 24  
7.3 Procedures..... 24

**8. CLEANING ..... 26**  
8.1 General..... 26

**9. FIBER OPTIC SPLICING ..... 27**  
9.1 Splice Assembly..... 27

# NASA-STD-8739.5A

<b>10.</b>	<b>FIBER OPTIC CABLE ASSEMBLIES .....</b>	<b>28</b>
10.1	General.....	28
10.2	Cable Assembly .....	28
10.3	Post Assembly Testing.....	29
<b>11.</b>	<b>FIBER OPTIC ASSEMBLIES.....</b>	<b>31</b>
11.1	General.....	31
11.2	Fiber Optic Connector Termination.....	31
11.3	Post Fiber Optic Connector Termination.....	31
11.4	Fiber Optic Routing .....	32
11.5	Fiber Optic Assembly Testing .....	32
<b>12.</b>	<b>FIBER OPTIC CABLE ASSEMBLY INSTALLATION .....</b>	<b>34</b>
12.1	General.....	34
12.2	Design Requirements and Considerations for Fiber Optic Assembly Installation .....	34
<b>13.</b>	<b>QUALITY ASSURANCE PROVISIONS.....</b>	<b>36</b>
13.1	General.....	36

## LIST OF APPENDICES

Appendix A. Fiber End-Face Inspection Criteria After Polishing.....	37
---	----

## LIST OF FIGURES

Figure 7-1. Parts of a Typical Optic Cable .....	25
Figure A-1. Bare Fiber - Back-Lit .....	37
Figure A-2. Bare Fiber - Back-Lit - Continued .....	38
Figure A-3. Fiber in Ferrule - Back-Lit .....	39
Figure A-4. Fiber in Ferrule - Back-Lit - Continued .....	40
Figure A-5. Fiber in Ferrule - Direct-Lit, No Core Illumination.....	41

# **FIBER OPTIC TERMINATIONS, CABLE ASSEMBLIES, AND INSTALLATION**

## **1. SCOPE**

### **1.1 Purpose**

This Standard sets forth termination and cabling requirements for optical fiber and cable assemblies.

### **1.2 Applicability**

1.2.1 This Standard is approved for use by NASA Headquarters and NASA Centers, including Component Facilities, and Technical and Service Support Centers, and may be cited in contract, program, and other Agency documents as a technical requirement. This Standard may also apply to the Jet Propulsion Laboratory other contractors, grant recipients, or parties to agreements only to the extent specified or referenced in their contracts, grants, or agreements.

1.2.2 This standard applies to critical work, as defined by NPD 8730.5. Critical work is any task that if performed incorrectly or in violation of prescribed requirements poses a credible risk of loss of human life; serious injury; loss of a Class A, B, or C payload (see NPR 8705.4); loss of a Category 1 or Category 2 mission (see NPR 7120.5); or loss of a mission resource valued at greater than \$2M (e.g., NASA space flight hardware, Government test or launch facility).

1.2.3 For payload installation operations where Technical Order 1-1A-14, Installation and Repair Practices, Aircraft Electric and Electronic Wiring, is the baseline or primary design and quality standard, the applicable requirements herein are limited to those in Chapter 12, Fiber Optic Cable Assembly Installation.

1.2.4 Use of the term “supplier” applies to any entity who is manufacturing hardware in accordance with the requirements herein including NASA Centers and NASA contractors.

# NASA-STD-8739.5A

## 2. APPLICABLE AND REFERENCE DOCUMENTS

### 2.1 Applicable Documents

The documents listed in this section contain provisions that constitute requirements of this standard as cited in the text. Use of more recent issues of cited documents may be authorized by the responsible SMA Technical Authority. The applicable documents are accessible via the NASA Technical Standards System at <https://standards.nasa.gov> or may be obtained directly from the Standards Developing Organizations or other document distributors.

#### 2.1.1 Government Documents

NPD 8730.5	NASA Quality Assurance Program Policy
NPR 7120.5	NASA Space Flight Program and Project Management Requirements
NPR 8705.4	Risk Classification for NASA Payloads
NASA-STD-8739.1	Workmanship Standard for Polymeric Application on Electronic Assemblies
NASA-STD-8739.6	Implementation Requirements for NASA Workmanship Standards

#### 2.1.2 Non-Government Documents

ANSI Z136.1	Safe Use of Lasers
ANSI Z136.2	Safe Use of Optical Communication Systems Utilizing Laser Diode and LED Sources

### 2.2 Reference Documents

The documents listed in this section do not constitute requirements of this standard, but are cited in the text to provide further clarification and guidance.

#### 2.2.1 Government Documents

NASA-HDBK-8709.22	Safety and Mission Assurance Acronyms, Abbreviations, and Definitions
-------------------	---

#### 2.2.2 Non-Government Documents

The following fiber optic test procedures should be considered for all optical fiber cable assemblies, splices, and/or connectors, as applicable:

EIA/TIA 440	Fiber Optic Terminology
-------------	-------------------------

## NASA-STD-8739.5A

EIA-455 (FOTP 1)	Cable Flexing for Fiber Optic Interconnection Devices
EIA-455-3 (FOTP 3)	Procedure to Measure Temperature Cycling Effects on Optical Fibers, Optical Cable, and Other Passive Fiber Optic Components.
EIA-455-4 (FOTP 4)	Fiber Optic Connector/Component Temperature Life.
EIA-455-5 (FOTP 5)	Humidity Test Procedure for Fiber Optic Connecting Devices
EIA-455-6 (FOTP 6)	Cable Retention Test Procedure for Fiber Optic Cable Interconnecting Devices
EIA-455-11 (FOTP 11)	Vibration Test Procedure for Fiber Optic Connecting Devices and Cable
EIA-455-12 (FOTP 12)	Fluid Immersion Test for Fiber Optic Components
EIA-455-13 (FOTP 13)	Visual and Mechanical Inspection of Fiber, Cables, Connectors etc.
EIA-455-14 (FOTP 14)	Fiber Optic Shock Test (Specified Pulse)
EIA-455-15 (FOTP 15)	Altitude Immersion
EIA-455-16 (FOTP 16)	Salt Spray
EIA-455-17 (FOTP 17)	Maintenance Aging of Fiber Optic Connectors and Terminated Cable Assemblies
EIA-455-21 (FOTP 21)	Mating Durability for Fiber Optic Interconnecting Devices
EIA-455-25 (FOTP 25)	Repeated Impact Testing of Fiber Optic Cables and Cable Assemblies
EIA-455-26 (FOTP 26)	Crush Resistance of Fiber Optic Interconnecting Devices
EIA-455-33 (FOTP 33)	Fiber Optic Cable Tensile Loading and Bending Test
EIA-455-34 (FOTP 34)	Interconnection Device Insertion Loss Test
EIA-455-36 (FOTP 36)	Twist Test for Fiber Optic Connecting Devices
EIA-455-37 (FOTP 37)	Low or High Temperature Bend Test for Fiber Optic Cable
EIA-455-39 (FOTP 39)	Fiber Optic Cable Water Wicking Test
EIA-455-41 (FOTP 41)	Compressive Loading Resistance of Fiber Optic Cables

## NASA-STD-8739.5A

EIA-455-42 (FOTP 42)	Optical Crosstalk in Fiber Optic Components
EIA-455-53 (FOTP 53)	Attenuation by Substitution Measurement for Multi-mode Graded-Index Optical Fibers or Fiber Assemblies Used in Long Length Communication Systems
EIA-455-57 (FOTP 57)	Optical Fiber End Preparation and Examination
EIA-455-59 (FOTP 59)	Measurement of Fiber Point Defects using an Optical Time Domain Reflectometer
EIA-455-60 (FOTP 60)	Measurement of Fiber or Cable Length Using an OTDR
EIA-455-61 (FOTP 61)	Measurement of Fiber or Cable Attenuation Using an OTDR
EIA-455-62 (FOTP 62)	Measurement of Optical Fiber Macrobend Attenuation
EIA-455-69 FOTP 69)	Test Procedure for Evaluation of the Effect of Minimum and Maximum Exposure Temperatures on the Optical Fiber
EIA-455-85 (FOTP 85)	Fiber Optic Cable Twist Test
EIA-455-88 (FOTP 88)	Fiber Optic Cable Bend Test
EIA-455-91 (FOTP 91)	Fiber Optic Cable Twist-Bend Test
EIA-455-95 (FOTP 95)	Absolute Optical Power Test for Optical Fibers and Cables
EIA-455-96 (FOTP 96)	Fiber Optic Cable Long-Term Storage Temperature Test for Extreme Environments
EIA-455-98 (FOTP 98)	Fiber Optic Cable External Freezing Test
EIA-455-171 (FOTP 171)	Attenuation by Substitution Measurement for Short-Length Multimode Graded-Index and Single-Mode Optical Fiber Cable Assemblies
NRL/MR/6505-92-6963	Procedure for Measuring Radiation-Induced Attenuation in Optical Fibers and Optical Cables

### 2.3 Order of Precedence

2.3.1 Where conflicts exist between this standard and applicable Federal and State regulations, the applicable regulations take precedence.

2.3.2 Where conflicts exist between this standard and applicable Agency directives, the applicable Agency directives take precedence.

## **NASA-STD-8739.5A**

2.3.3 Where conflicts exist between this standard and standards that contain provisions that constitute requirements of this standard as cited in the text, this standard takes precedence, except in the case where those standards are Federal or State regulations.

2.3.4 Where conflicts exist between a requirement that is meant to be applied generally and a requirement that is specific, the requirement that is specific takes precedence.

2.3.5 Clarification and further resolution of conflicts is resolved by the responsible SMA Technical Authority.

# NASA-STD-8739.5A

## 3. ACRONYMS AND DEFINITIONS

### 3.1 Acronyms and Abbreviations

ANSI	American National Standards Institute
EIA	Electronic Industries Association
ESD	Electrostatic Discharge
FOTP	Fiber Optic Test Procedure
LED	Light Emitting Diode
lm/m <sup>2</sup>	Lumens per square meter
NASA	National Aeronautics and Space Administration
NASA-STD	NASA Standard
OTDR	Optical Time Domain Reflectometry
SDS	Safety Data Sheet
TIA	Telecommunications Industry Association
UV	Ultraviolet

### 3.2 Definitions

*Note: Definitions for SMA terms are found in NASA-HDBK-8709.22, Safety and Mission Assurance Acronyms, Abbreviations, and Definitions. Terms unique to this NASA-STD are listed below. Additional related terms and definitions can be found in EIA/TIA-440, Fiber Optic Terminology.*

**Adhesive.** A polymeric compound, usually an epoxy, used to secure the optical fiber in a splice assembly or connector.

**Back-lit.** A method of illuminating the fiber end-face by launching incoherent light into the optical fiber core through the opposite end of the fiber.

**Backscatter.** The return of a portion of scattered light to the input end of a fiber; the scattering of light in the direction opposite to its original propagation.

**Buffer.** A material applied over the coating that may be used to protect an optical fiber from physical damage, providing mechanical isolation or protection, or both.

## NASA-STD-8739.5A

**Bend Radius, Long Term.** The minimum radius to which a cable, without tensile load, can be bent for its lifetime without causing broken fibers, a localized weakening of the fibers, or a permanent increase in attenuation.

**Bend Radius, Short Term.** The minimum radius to which a cable can be bent while under the maximum installation load without causing broken fibers, a localized weakening of the fibers, or a permanent increase in cable attenuation.

**Cladding.** The dielectric material surrounding the core of an optical fiber.

**Cleave.** The process of separating an optical fiber by a controlled fracture of the glass for the purpose of obtaining a fiber end that is flat, smooth, and perpendicular to the fiber axis.

**Coating.** A material put on a fiber during the drawing process to protect it from the environment.

**Coupling Loss.** The optical power loss suffered when light is coupled from one optical device to another.

**Degas.** The removal of entrapped bubbles from a viscous fluid by placing that fluid in a centrifuge or vacuum.

**Direct-lit.** A method of illuminating the fiber end-face by projecting a light source onto the fiber.

**Ferrule.** A mechanical fixture, generally a rigid tube, used to confine the stripped end of a fiber bundle or an optical fiber.

**Fiber (Optical).** A filament shaped optical waveguide made of dielectric material.

**Fiber Optic Cable.** A fiber, multiple fiber or fiber bundle in a cable structure fabricated to meet optical mechanical and environmental specifications.

**Fiber Optic Connector.** A fiber optic component normally assembled onto a cable and attached to a piece of apparatus for the purpose of providing interconnecting/disconnecting of fiber optic cables.

**Glass Transition Temperature (T<sub>g</sub>).** The temperature above which an amorphous polymer displays viscous behavior caused by chain slip.

**Insertion Loss.** The optical attenuation caused by the insertion of an extra optical component into an optical system.

**Installation Load, maximum.** The maximum load which can be applied along the axis of a cable during installation without breaking fibers or causing a permanent increase in the cable attenuation.

## NASA-STD-8739.5A

**Interferometer.** An instrument that employs the interference of light waves for purposes of measurement.

**Laser.** A device that produces coherent optical radiation by stimulated emission and amplification.

**Mode.** In general, an electromagnetic field distribution that depends on wavelength of light and material properties of the traveling medium. In guided wave propagation, such as through a waveguide or optical fiber, a distribution of electromagnetic energy that satisfies Maxwell's equations and boundary conditions. In terms of ray optics, a possible path followed by light rays dependent on index of refraction, wavelength of light and waveguide dimensions.

**Multi-mode Fiber.** An optical fiber that will allow two or more bound modes to propagate in the core at the wavelengths of interest.

**Optical Time Domain Reflectometry (OTDR) Backscattering Technique.** A method for characterizing an optical fiber whereby an optical pulse is transmitted through the fiber and the optical power of the resulting light scattered and reflected back to the input is measured as a function of time.

**Pistoning.** The axial movement of an optical fiber within a connector or connector ferrule.

**Preconditioning.** Preparation of the fiber optic cable and/or jacket prior to manufacturing. This is usually a thermal cycling process, but may consist of other environmental factors.

**Refraction.** The bending of a beam of light in transmission through an interface between two dissimilar media or in a medium whose refractive index is a continuous function of position, for example graded index medium.

**Repair.** Action on a nonconforming product to make it acceptable for the intended use.

**Rework.** Action on a nonconforming product to make it conform to the requirements.

**Single-Mode Fiber.** An optical fiber in which only the lowest order bound mode can propagate at the wavelength of interest.

**Soxhlet Extraction.** A process similar to distillation used to separate materials. Uses relative to this standard include removing oils, resins, or other contaminants from cotton swabs or wipes.

**Splice.** An interconnection method for joining the ends of two optical fibers in a permanent or semi-permanent fashion.

**Splice, Chemical Splice.** A permanent joint made with an adhesive such as UV-cured polymer or epoxy.

## NASA-STD-8739.5A

**Splice, Fusion Splice.** A splice accomplished by the application of localized heat sufficient to fuse or melt the ends of two lengths of optical fiber, forming a continuous single optical fiber.

**Splice, Mechanical.** A fiber splice accomplished by fixtures or materials, rather than by thermal fusion.

**Splice Enclosure.** A device surrounding the spliced area of an optical fiber used to protect the splice from physical damage.

**Splice Tray.** A container used to organize and protect spliced fibers.

**Strength Member.** That part of a fiber optic cable composed of kevlar aramid yarn, steel strands, or fiberglass filaments included to increase the tensile strength of the cable, and in some applications, to support the weight of the cable.

**Ultraviolet (UV).** Optical radiation for which the wavelengths are shorter than those for visible radiation that is approximately between 1nm and 400nm.

**Working Life.** The duration of time that an adhesive can be used for a process and still achieve the intended result, with the intended quality, as measured from the time it is mixed or is fully defrosted, in the case of frozen sub-batches.

**Workmanship Temperature Cycling.** The process of stress testing a completed optical assembly to verify its optical performance, mechanical assembly attributes, or reliability is not diminished or otherwise adversely affected.

# NASA-STD-8739.5A

## 4. GENERAL

### 4.1 General

4.1.1 When there is a conflict between the requirements of NASA-STD-8739.6 and those herein, the requirements in NASA-STD-8739.6 shall take precedence.

4.1.2 When Electrostatic Discharge (ESD) control is required during workmanship operations defined herein, the ESD control requirements of NASA-STD-8739.6 shall apply.

4.1.3 A program shall be established to assure continuing process capability.

4.1.4 Special controls shall be developed for process parameters and equipment settings that influence product compliance with critical performance and quality requirements.

### 4.2 Design Considerations

The following considerations shall be used when selecting and qualifying parts, materials and processes used for terminating fiber via splicing or when manufacturing cables that meet the requirements of this standard:

- a. Construction, weight, and physical dimension requirements for cables, splices and subsystems.
- b. Tensile strength continuity between spliced cables without concentrating the cable tensile load on the splice junction.
- c. Cable stress relief and environmental sealing between the cables and splice, or the cables and the connectors, to prevent the entry of external contaminants and to provide protection from both cable tensile forces and cable axial compressive forces.
- d. Optical, mechanical, and environmental performance requirements for cables, splices and subsystems.
- e. Physical and functional interchangeability, for all splice parts and for all connector parts of the same type without the need for modification of the parts or of the splicing or terminating equipment.
- f. Use only of connector parts from the same manufacturer in a given mated connector pair to prevent connector intermateability problems.
- g. Protection against electrolysis and corrosion when dissimilar metals are used in contact with each other.
- h. Seals for isolating splice and connector interiors from humidity and contamination.
- i. Mechanical protection parts and methods for splices. The use of splice trays is recommended for multiple splices.

## **NASA-STD-8739.5A**

- j. Staking requirements in NASA-STD-8739.1.
- k. Minimum fiber and cable bend radii, both short term and long term.
- l. Use of clear heat shrinkable sleeving to improve ability to inspect.

## **NASA-STD-8739.5A**

### **5. TRAINING AND CERTIFICATION PROGRAM**

This chapter has been superseded by NASA-STD-8739.6. Refer to NASA-STD-8739.6 for applicable training requirements.

# NASA-STD-8739.5A

## 6. FACILITIES, EQUIPMENT AND MATERIALS

### 6.1 Environmental Conditions

6.1.1 The environmental control requirements of NASA-STD-8739.6 shall apply.

6.1.2 Light intensity shall be a minimum of 1077 lumens per square meter (lm/m<sup>2</sup>) (100 foot-candles) on the surface where fiber optic fabrication operations are being performed, inspected, or tested. Supplemental lighting may be used to achieve the required lighting levels.

### 6.2 Tools and Equipment

6.2.1 The tool and equipment selection and control requirements of NASA-STD-8739.6 shall apply. See NASA-STD-8739.6 for metrology and calibration requirements.

6.2.2 The supplier's process documentation for tool and equipment use and control shall be available for review and approval prior to processing mission hardware.

#### 6.2.3 Fiber Stripping Tools

6.2.3.1 Chemical stripping materials shall be of a composition that will not impart damage to the optical fiber or termination elements. Refer to Safety Data Sheets (SDS) for proper handling of chemical stripping materials.

#### 6.2.3.2 Mechanical Stripping Tools

6.2.3.2.1 Mechanical stripping tools shall be used in accordance with manufacturer specifications.

6.2.3.2.2 Mechanical stripping tools shall not impart damage to the optical fiber or termination elements.

6.2.3.2.3 Fixed fiber diameter tools shall remove the coating from one specific fiber diameter (e.g., 125 microns).

6.2.3.2.4 Variable fiber diameter tools shall use interchangeable die to accommodate the different fiber diameters.

*Caution: Stripping can cause nicks, scratches, or chips that are not easily detectable. Use Extreme care when selecting and evaluating tools.*

#### 6.2.4 Fiber Cleaving Tools

6.2.4.1 The fiber cleaving tool design shall be such that the cleaved fiber end is retained, thus preventing possible injury to personnel.

6.2.4.2 The following capabilities of the selected fiber cleaving tools shall be demonstrated prior to use for producing mission hardware:

## NASA-STD-8739.5A

- a. Capable of allowing a clean, fragment-free, crack-free cleave which minimizes chips or other defects as shown in Appendix A on the cleaved fiber end.
- b. Capable of allowing the operator to control the strip length of the fiber to meet end item design and quality requirements.
- c. Capable of producing a cleaved fiber with an end-face angle as required by engineering documentation.

### **6.3 Inspection Aids**

6.3.1 Magnification aids shall be capable of viewing both the bare optical fiber and the termination without imparting damage.

6.3.2 Magnification aids shall be capable of rendering true colors, proportional dimensions, and adequate resolution at the magnification chosen to perform the specified inspection.

6.3.2.1 For inspection of cleanliness, chemical strip wicking, cracks, nicks, and cuts in the glass fiber and coating, magnification shall be between 50X and 80X.

6.3.2.2 For inspection of connector end-faces and cleaved bare fibers, magnification shall be 100X or greater.

6.3.3 For critical end-face measurements, an interferometer shall be used for inspections.

6.3.4 Additional Nondestructive Inspection Methods

6.3.4.1 The use of other nondestructive inspection methods (e.g., laser or automated inspection systems) is permitted. The method chosen shall be fully documented and not damage parts.

6.3.4.2 When other nondestructive inspection methods are used per 6.3.4.1, inspectors shall be trained to use the applicable controlled procedure.

### **6.4 Storage and Handling**

6.4.1 Containers shall be compatible with the stored materials.

6.4.2 Personnel shall ensure that hands and tools are clean prior to processing optical parts.

6.4.3 Stripped fibers or connector interfaces shall not be handled with bare hands due to risk of contamination to the fiber interface.

### **6.5 Parts and Materials Selection**

6.5.1 Vinyl dust caps shall not be used for flight applications.

## NASA-STD-8739.5A

6.5.2 See sections 4.2 and 9.1.3 for design considerations that should influence part and material selections.

### **6.6 Solvents**

6.6.1 The solvents used for the removal of grease, oil, dirt, or other debris shall be selected for their ability to remove both ionic and nonionic contamination.

6.6.2 The solvents used shall not degrade the materials or parts being cleaned.

6.6.3 Solvent containers shall be properly labeled.

6.6.4 Solvents shall be identified in materials lists.

6.6.5 SDS for solvents shall be available for personnel review and posted where solvents are being used.

6.6.6 When any type of water is used, drying shall be accomplished immediately after its use. Exposure of bare fiber to water should be minimized.

6.6.7 Solvents have the potential of removing marking information from parts. Marking permanency testing shall be performed as part of the selection and qualification process for any solvent.

### **6.7 Adhesives**

#### 6.7.1 Adhesives Selection

6.7.1.1 Adhesives shall be readily dispensable. Adhesives and the cure schedule shall be compatible with the part and process and not interfere with the termination performance.

6.7.1.2 Adhesives shall be noncorrosive.

6.7.1.3 Some adhesives can become brittle when they have come in contact with solvents used for cleaning fiber optic assemblies. Process design and qualification shall include verifying compatibility between the adhesives and the solvents.

6.7.1.4 Adhesives shall be selected such that the glass transition temperature ( $T_g$ ) is above the maximum temperature the assembly will be exposed to during system-level processing, during testing, and during the mission by a margin defined by project requirements.

#### 6.7.2 Process Controls

6.7.2.1 Dispensing equipment shall not contaminate the adhesive material (e.g., silicone lubricated syringes).

6.7.2.2 Adhesives shall not be used in the optical path of the termination.

## NASA-STD-8739.5A

6.7.2.3 Adhesives shall provide good wetting action that develops strong bonding between the fiber and the internal fiber channel of the connector or mechanical splice. Mixed adhesives shall be degassed (e.g., centrifuge or vacuum) before they are applied to optical fibers and connectors.

*Caution: Care should be taken not to introduce bubbles or voids into adhesive during mixing operations. Bubbles and voids in the adhesive surrounding optical fibers in connectors have been correlated to fiber breakage.*

6.7.3 For all multipart epoxies, a record for each mix batch shall be maintained.

6.7.4 The mix record for the multipart epoxy shall document:

- a. Unique batch identifier (e.g. serial number).
- b. The unique identifier of each sub-batch if separated into sub-batches (i.e. into syringes). It is recommended that sub-batch identifiers are a derivative of the parent batch identifier.
- c. Materials used (including manufacturer, part number, traceability code, expiration date)
- d. The mix ratio
- e. Ambient conditions (temperature, humidity)
- f. Time mixed
- g. Working life
- h. Date
- i. Operator
- j. Mix procedure name or number and revision
- k. Test specimen acceptance test results

6.7.5 The mix record for premixed, preloaded syringes as obtained directly from a commercial supplier may not be available. When this is the case, the manufacturer name, product identification (e.g. part number) and lot date code for each syringe shall be recorded and used for product traceability.

6.7.6 When using preloaded syringes instead of a newly mixed batch, data shall be recorded to provide evidence that the working life was not exceeded.

6.7.7 Syringes used for epoxy dispensing shall be verified to be silicone-free prior to use. Silicones are used by some syringe suppliers to reduce plunger friction. Silicone is detrimental to polymeric bond reliability.

## NASA-STD-8739.5A

6.7.8 A test specimen shall be produced for all mixed batches of adhesives to verify that the mix was performed correctly, prior to applying it to mission hardware. With NASA pre-approval the test specimen may be cured concurrently with the material used on the mission hardware (i.e. cured with the mission hardware).

6.7.9 The witness sample shall be stored under the standard controlled laboratory conditions defined in NASA-STD-8739.6.

6.7.10 The witness sample shall be traceable to the mix record.

6.7.11 Adhesive lot numbers and mix records shall be documented and traceable to the hardware.

6.7.12 Uncontrolled heat sources (e.g., heat guns or hotplates) to cure adhesives shall not be used.

### **6.8 Material Shelf Life Requirements**

6.8.1 Material storage shall be controlled by shelf life labels attached to each material container.

6.8.2 Records for manufacturing date, lot number, and receiving date of each material shipment shall be maintained.

6.8.3 Material shall not be used if the shelf life has expired.

6.8.4 Shelf life may be extended one time, for one-half of the original shelf life with prior NASA approval, based on test results that demonstrate material acceptability in accordance with the manufacturer's specification and engineering documentation..

6.8.5 The working life of an adhesive shall be defined for the processes for which it will be used and recorded in the mix record.

### **6.9 Personnel Protection**

6.9.1 All necessary safety precautions shall be taken to protect personnel from injury while fabricating, inspecting, or testing fiber optic cable assemblies. The safety requirements of NASA-STD-8739.6 apply.

6.9.2 Protection from Bare Fibers

6.9.2.1 Personnel who may come in contact with bare fibers shall wear wrap-around safety goggles for eye protection.

6.9.2.2 Slivers of bare fiber shall be wrapped in a heavy tape (e.g., duct tape) and placed in a specially marked container for later disposal.

## NASA-STD-8739.5A

6.9.2.3 Fiber waste is a personnel safety concern and shall be handled as such during disposal. Incineration is the recommended method of safe disposal.

6.9.3 Protection from eye exposure to light sources shall be in accordance with ANSI Z136.1, American National Standard for the Safe Use of Lasers; and ANSI Z136.2, American National Standard for the Safe Use of Optical Fiber Communication Systems Utilizing Laser Diode and LED Sources.

*Warning: Some light sources used in testing and operating fiber optic cable assemblies may cause permanent eye damage.*

## **7. OPTICAL FIBER END PREPARATION**

### **7.1 General**

All parts, materials, tooling and equipment shall be verified for compliance with the engineering documentation prior to the start of fiber end preparation activities.

### **7.2 Safety Requirements**

The requirements of 6.9.2 apply for protection from bare fibers when preparing optical fiber ends.

### **7.3 Procedures**

7.3.1 Fiber optic cables shall be thermally preconditioned prior to preparation for termination to provide material stability in the final assembly.

7.3.2 Cables (see Figure 7-1 for a typical fiber optic cable) shall be prepared for termination in a fashion that will allow for the fiber to be exposed without sustaining damage or contamination.

7.3.3 All outer protective materials shall be removed to the dimensions defined in the engineering documentation.

7.3.4 The use of chemical strippers (e.g., acetone) for removal of certain buffer materials is acceptable. Chemically stripped fiber ends shall be thoroughly cleaned to remove any residual chemical stripping compounds and buffer materials immediately after stripping.

7.3.5 All parts that come in contact with the adhesives, including all dispenser parts and mixing pans, as well as the fiber and connector to be bonded, shall be thoroughly cleaned with appropriate solvents before bonding.

7.3.6 Procedures for collecting, controlling, and disposing of fiber optic waste shall be implemented.

7.3.7 The connector end-face may be finished either by polishing or cleaving provided that the process is compatible with the finished product quality and performance requirements.

7.3.8 The optical fiber shall be back-lit using an incoherent, low intensity light source from the opposite end of the cable, without touching the fiber, to inspect for cracks on or through the fiber end-face before and after polishing.

7.3.9 When the opposite end of the cable is not accessible, inspection techniques which produce core illumination shall be used.

# NASA-STD-8739.5A

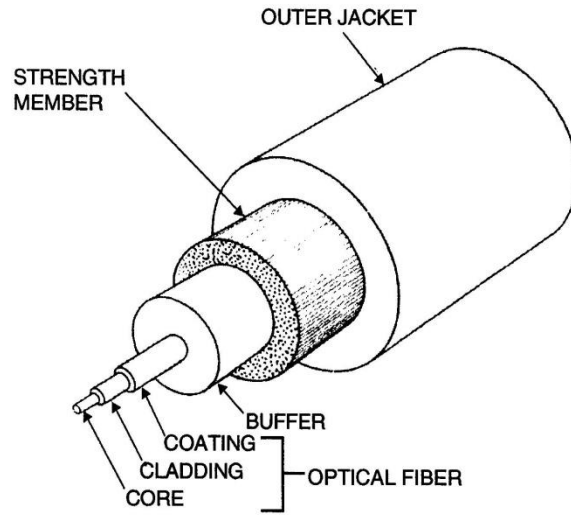

Figure 7-1. Parts of a Typical Optic Cable

# NASA-STD-8739.5A

## 8. CLEANING

### 8.1 General

8.1.1 Cleaning procedures shall address the processes to be used for cleaning, drying parts, and visual inspection.

8.1.2 Fiber optic terminations to be cleaned shall be handled in a manner that will not degrade or damage the termination.

8.1.3 Terminations shall be cleaned within a time frame that permits removal of all contaminants.

#### 8.1.4 Manual Cleaning

8.1.4.1 Manual cleaning of fiber optic terminations shall be performed using a solvent and a wipe or swab.

8.1.4.2 The wipe or swab shall be non-abrasive, lint free, and either soxhlet extracted, or equivalent, to minimize residues.

8.1.5 Cleaning processes and materials shall not degrade the optical characteristics of the termination or impart damage to the optical fiber or assembly.

8.1.6 Cleaning shall ensure removal of dirt, oil, grease, and particulate matter.

8.1.7 If not terminated immediately, prepared cable components shall be protected from contamination.

## **9. FIBER OPTIC SPLICING**

### **9.1 Splice Assembly**

9.1.1 Prior to splicing, the fiber shall be examined to ensure there is no contamination, blockage of the internal fiber channel in parts or fixturing, unacceptable conditions as shown in Appendix A as applicable, or other nonconformances with specific requirements in the engineering documentation.

9.1.2 The prepared fiber shall not be used to check for blockage of the fiber channel in parts or fixturing.

9.1.3 Completed fusion splices shall be able to withstand a minimum 4.45 newton (1 pound) pull test, or as specified in the engineering documentation.

9.1.4 Mechanical splicing shall not be used for mission hardware assemblies.

9.1.5 Chemical splicing shall only be used for temporary joining of fiber optics (i.e., testing).

#### **9.1.6 Completed Splices**

9.1.6.1 Splices shall not be located in flexure areas of the cable except when a splice is recoated and re-jacketed in accordance with the manufacturer's original specifications.

9.1.6.2 Splices shall be protected from inadvertent mechanical damage using an enclosure or an equivalent method.

9.1.6.3 Strength members shall be secured to splice enclosures, or other means of protection, to prevent mechanical stress on the optical fiber.

9.1.7 Finished splices shall be inspected visually and optically to verify that they meet physical quality and optical performance requirements. Optical Time Domain Reflectometry (OTDR), as well as other appropriate test procedures from Section 2.2.2, may be applied.

9.1.8 Test records shall be maintained with the assembly/subassembly documentation.

# NASA-STD-8739.5A

## 10. FIBER OPTIC CABLE ASSEMBLIES

### 10.1 General

A fiber optic cable assembly consists of a prepared fiber optic cable, connector, and associated hardware.

### 10.2 Cable Assembly

10.2.1 Fiber optic cables shall be identified in such a way to distinguish these cables from wire or coaxial cables.

10.2.2 Cable connectors shall be permanently marked with mating connector designation within 15 cm (6 in) of connector body, or as stated in the engineering documentation.

10.2.3 Prior to assembly, compliance of all parts, materials, and tooling with critical dimensions, conditions, and quality controls and requirements, defined in the engineering documentation shall be verified.

10.2.4 Prior to assembly, prepared fiber optic cables shall be subject to documented in-process visual inspection for the following:

- a. Correct cable stripping dimensions.
- b. Strength member damage.
- c. Cracks, nicks, cuts, or other damage in the termination area to all cable components, including the optical fiber.
- d. Chemical strip wicking or damage.
- e. Cleanliness as per Chapter 8.
- f. All other critical dimensions, conditions and quality criteria defined herein and in the engineering documentation.

*Note: The requirement in NASA-STD-8739.6 prohibiting operators from inspecting their own work applies.*

10.2.5 The prepared fiber shall not be used to check for blockage.

10.2.6 Prior to assembly, prepared fiber optic connector parts shall be examined for the following:

- a. Blockage in the internal fiber channel.
- b. Cleanliness as per Chapter 8.

## NASA-STD-8739.5A

- c. Cracks or deformities on the connector ferrule.

10.2.7 Completed cable assemblies shall be inspected for the following:

- a. Strength member, when visible, is uniformly distributed and securely attached to the connector.
- b. Heat shrinkable sleeving and crimp sleeve is positioned properly.
- c. Connector end-face geometry is compliant with engineering documentation.
- d. Connector ferrule length is compliant with engineering documentation.
- e. Connector end-face quality is in accordance with Appendix A or the engineering documentation.
- f. Proper positioning and attachment of the strain relief device per the engineering documentation.
- g. Cleanliness as per Chapter 8.
- h. Cable axial alignment with the connector is within 5 cm (2 inches) of the termination or per the engineering documentation.
- i. Freedom from nicks exposing underlying elements.
- j. Freedom from kinks or twists.
- k. Cable designation marking.

10.2.8 If cracks in a flight fiber optic cable end-face are found, the cable shall be re-terminated or scrapped. Re-polishing to fix cracks in flight hardware is prohibited.

### **10.3 Post Assembly Testing**

10.3.1 All completed flight cable assemblies shall be tested to ensure that measured optical performance (e.g., insertion loss or return loss) meets or exceeds the performance requirements in the engineering documentation.

10.3.2 Records of testing shall be maintained with the assembly or subassembly documentation. Section 2.2.2 provides a list of standard test and verification methods.

10.3.3 Upon completion of the test(s) required in paragraph 10.3.1, the flight cable assemblies shall be subjected to workmanship temperature cycling to ensure assembly geometries and conditions are stable.

10.3.4 Following workmanship temperature cycling per 10.3.3, the measured optical performance of the cable shall be retested per paragraph 10.3.1.

## NASA-STD-8739.5A

10.3.5 Following retesting per 10.3.3 the cable shall be visually inspected to verify conformance with the quality criteria and requirements defined in in the engineering documentation for the following:

- a. Cracks in fiber end-face.
- b. Pistoning of the fiber in connector.
- c. Cracks in epoxy bond line at the end-face.
- d. Shrinkage of the cable components (e.g. buffer, strength members, jacket).

10.3.6 Cracks in the fiber end-face of fiber optic assemblies shall be inspected using direct light, and back lighting with an incoherent, low intensity light source from the opposite end of the fiber, without touching the fiber as part of the examination.

## 11. FIBER OPTIC ASSEMBLIES

### 11.1 General

Fiber optic assemblies include such devices as electro-optical components, star couplers, and splice enclosures. The optical fibers found in these devices consist of the fiber (core and cladding) and the coating surrounding the fiber. Optical fibers differ from fiber optic cables which may have a buffer, loose tube, strength members, and outer jacket as additional protective sheathing.

### 11.2 Fiber Optic Connector Termination

11.2.1 Prior to assembly, compliance of all parts, materials, and tooling with critical dimensions, conditions, and quality controls and requirements, defined in the in the engineering documentation shall be verified.

11.2.2 Prior to assembly, prepared optical fibers shall be subject to documented in-process visual inspection for the following:

- a. Correct stripping dimensions.
- b. Cracks, nicks, cuts, or other damage to the coating and fiber.
- c. Chemical strip wicking or damage.
- d. Cleanliness per Chapter 8.

*Note: The requirement in NASA-STD-8739.6 prohibiting operators from inspecting their own work applies.*

11.2.3 The prepared fiber shall not be used to check for blockage.

11.2.4 Prior to assembly, fiber optic connector parts shall be examined for the following:

- a. Blockage in the internal fiber channel.
- b. Cleanliness per Chapter 8.
- c. Cracks or deformities on the connector ferrule.

### 11.3 Post Fiber Optic Connector Termination

11.3.1 Terminated fiber optics shall be inspected for the following:

- a. Heat shrinkable sleeving and/or crimp sleeve is positioned properly.
- b. Connector end-face geometry is compliant with engineering documentation.

## NASA-STD-8739.5A

c. Connector end-face requirements are in accordance with Appendix A or engineering documentation.

d. Proper positioning of the strain relief per the engineering documentation.

11.3.2 The inspection of terminated fiber optics shall use back lighting with an incoherent, low intensity light source from the opposite end of the fiber, without touching the fiber as part of the examination.

11.3.3 When the opposite end of the fiber is not accessible, inspection of terminated fiber optics shall use techniques which produce core illumination.

11.3.4 If cracks in a flight fiber optic assembly end-face are found, the assembly shall be re-terminated or scrapped. Re-polishing to fix cracks in flight hardware is prohibited.

### 11.4 Fiber Optic Routing

11.4.1 The optical fiber shall not be routed over sharp edges or corners unless appropriate protection is provided.

11.4.2 The minimum bend radius of the routed optical fiber shall be in accordance with the engineering documentation.

11.4.3 The optical fiber shall be tied down (e.g., lacing cord) per the engineering documentation to prevent subsequent damage due to processing, handling and operational environments.

11.4.4 The ties shall not pinch, deform or otherwise stress the optical fiber.

11.4.5 The ties shall be loose enough to allow the fibers to move slightly due to thermal expansion and contraction.

*Note: Overly tight ties can cause microbending of the fiber and affect performance or reliability. Conduits should be used to route optical fibers through areas where access is limited or restricted. Optical fiber should be secured in conduits in a manner to preclude damage. See 11.4.3.*

11.4.6 Staking or conformal coating shall only be applied to optical fiber when specified in the engineering documentation. See NASA-STD-8739.1 for Workmanship requirements for staking.

### 11.5 Fiber Optic Assembly Testing

11.5.1 All finished flight fiber optic assemblies shall be tested to ensure that measured optical performance meets the performance requirements in the engineering documentation.

11.5.2 Records of testing shall be maintained with the assembly or subassembly documentation (Requirements). Section 2.2.2 provides a list of available test and verification methods.

## NASA-STD-8739.5A

11.5.3 Upon completion of the test(s) required in paragraph 11.5.1 the flight fiber optic assemblies shall be subjected to temperature cycling as identified in the engineering documentation to demonstrate the assembly's mechanical and optical stability following exposure to mission-relevant temperatures.

11.5.4 Upon completion of the environmental test in 11.5.3, retest the flight fiber optic assembly per paragraph 11.5.1.

11.5.5 Following the optical retest in 11.5.4, the flight fiber optic assembly shall be examined for the following:

- a. Cracks in fiber end-face.
- b. Pistoning of the fiber in connector or termination.
- c. Cracks in epoxy bond line at the end-face.
- d. Shrinkage of buffer or outer jacket.

11.5.6 The examination of the flight fiber optic assembly in [11.5.5](#) shall use direct and back lighting with an incoherent, low intensity light source from the opposite end of the fiber, without touching the fiber as part of the examination.

11.5.7 When the opposite end of the fiber is not accessible, the examination of the flight fiber optic assembly in [11.5.5](#) shall use inspection techniques that produce core illumination.

## **12. FIBER OPTIC CABLE ASSEMBLY INSTALLATION**

### **12.1 General**

12.1.1 Care is necessary to prevent damage to fiber optic cable assemblies during the installation process. Fiber optic cables shall only be installed and inspected by trained fiber optic operators and inspectors.

12.1.2 This chapter applies for both mission hardware as well as for fiber optic assemblies used in critical ground support equipment with the exception described in 12.2.12.

### **12.2 Design Requirements and Considerations for Fiber Optic Assembly Installation**

12.2.1 Fiber optic cable assemblies should not be combined in the same wiring bundle as wire or coaxial cable assemblies to ensure they are not exposed to handling practices that are acceptable for electrical cables but can damage optical cables.

12.2.2 The engineering documentation shall specify the maximum installation tensile load and the maximum use tensile load.

12.2.3 For fiber optic assemblies used in ground support equipment, the engineering documentation shall specify the maximum vertical rise for cable assemblies installed in raceways, trays, ducts or conduits.

12.2.4 The minimum short term and long term bend radii applicable to all operations during installation and use of the fiber optic assembly or cable shall be specified in the engineering documentation. A bend radius of not less than 10 times the cable diameter is recommended for long term bend radius.

12.2.5 The minimum bend radius shall not be violated at connector backshells (Requirement).

#### **12.2.6 Protection Constraints for Fiber Optic Cable Assemblies**

12.2.6.1 When installed, fiber optic cable assemblies shall be constrained to protect them from damage during operations on the ground, from movement during launch, and from movement in the mission as applicable.

12.2.6.2 The method of constraint (e.g. cable ties, staking) shall be specified in the engineering documentation.

12.2.7 Tie downs shall be tight enough to capture the fiber optic cable but shall not deform the cable outer jacket.

12.2.8 The ties shall not pinch, deform, kink, or otherwise stress the cable assembly.

12.2.9 Dust caps shall be installed on all connectors when not in use.

12.2.10 Vinyl dust caps shall not be used.

## **NASA-STD-8739.5A**

12.2.11 Fiber optic cable connector or termination end-faces shall be examined before each mate and cleaned if necessary in accordance with Chapter 8.

12.2.12 For payload installation operations in certified aircraft where Technical Order 1-1A-14, Installation and Repair Practices, Aircraft Electric and Electronic Wiring, is the baseline or primary design and quality standard, all requirements in this chapter shall be flowed to the work orders, procedures or other applicable engineering documentation used when installing optical cable and harness assemblies in NASA mission aircraft.

12.2.13 Partial operator training is recommended for individuals whose interactions with fiber optic assemblies is limited to assembly installation. Partial Level B Instructor training is recommended for instructors who will only teach operators who perform fiber optic installations in accordance with this chapter but will not terminate fiber or cable or repair terminations.

## 13. QUALITY ASSURANCE PROVISIONS

### 13.1 General

13.1.1 Workmanship shall be of sufficient quality to assure that the products meet the performance requirements of the engineering documentation and criteria delineated herein.

13.1.2 Inspection for acceptability shall be performed on all fiber optic terminations and cable assemblies to the requirements specified in this Standard.

13.1.3 If any elements of the fiber optic components are moved to aid inspection, they shall not be disturbed in a fashion that will cause damage.

13.1.4 X-ray or other means of automated inspection techniques are permissible provided that it has been determined that the x-ray emission level is not detrimental to the product being inspected.

13.1.5 Quality Assurance. The following functions shall be performed:

- a. Product Verification. Witness or verify that all tests, examinations, peer verifications, inspections, and measurements specified by this Standard and the engineering documentation have been performed.
- b. Personnel Qualifications. Verify that all personnel who assemble or inspect hardware in accordance with this Standard have been trained in accordance with NASA-STD-8739.6.
- c. Processes and Procedures. Verify, through manufacturing readiness reviews and in-process surveillance of all assembly operations that all processes and procedures implementing the requirements of this Standard are current, approved, adequate, and are being accurately used.
- d. Part Cleanliness. Verify that all parts were cleaned and undamaged prior to being assembled.
- e. Facility Control. Verify that the facility cleanliness, environmental conditions, and lighting requirements of NASA-STD-8739.6 and Chapter 6 herein are met.

**APPENDIX A. FIBER END-FACE INSPECTION CRITERIA AFTER POLISHING**







<p>PERFECT FIBER</p>	<p>Top View</p>  <p>Photo Image</p> 	<p>ACCEPTABLE</p>
<p>Oblique View</p> 	<p>Accept. Free from cracks, scratches, edge chips, hackles, pits and other anomalies and core is clearly discerned.</p>	
<p>EDGE CHIPS</p>	<p>Top View</p>  <p>Photo Image</p> 	<p>ACCEPTABLE</p>
<p>Oblique View</p> <p>Cladding Core</p> 	<p>Acceptable if chip maximum dimension <math>\leq 3\%</math> of fiber diameter and number of chips <math>\leq 3</math>.</p>	
<p>HACKLE</p>	<p>Top View</p>  <p>Photo Image</p> 	<p>REJECT</p>
<p>Oblique View</p> 	<p>Surface irregularity due to improper cleaving. Reject/re-cleave. Reject for splice connection. May be fixable by polishing if used in connector.</p>	

Figure A-1. Bare Fiber - Back-Lit

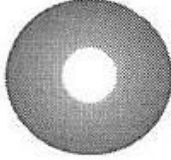
NASA-STD-8739.5A

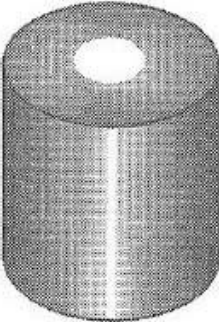

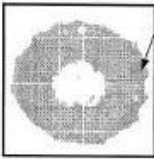
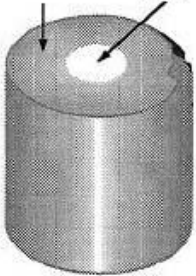

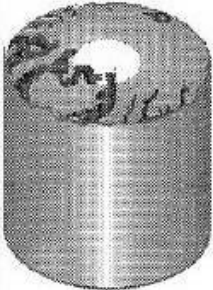

<p>SCRATCHES</p>	<p>Oblique View</p>  <p>Top View</p>  <p>Photo Image</p> 	<p>REJECT</p> <p>Reject/Repolish. Reject if performance is affected.</p>
<p>CRACK</p>	<p>Oblique View</p>  <p>Top View</p>  <p>Photo Image</p> 	<p>REJECT</p> <p>Any cracks are rejectable.</p>
<p>CRACK (Below Surface)</p>	<p>Oblique View</p>  <p>Cut Away View</p>  <p>Top View</p> 	<p>REJECT</p> <p>Any cracks are rejectable. Most often only detected by back-lit operation.</p>

Figure A-2. Bare Fiber - Back-Lit - Continued

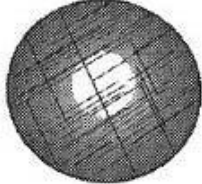
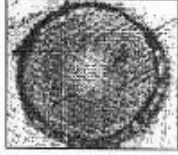
# NASA-STD-8739.5A



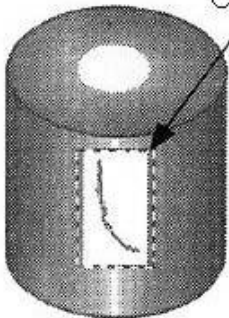

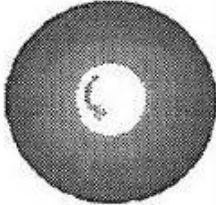
<p>PERFECT FIBER</p> <p>Top View</p>  <p>Ferrule Cladding Core Adhesive bond line</p>	<p>ACCEPT</p> <p>Free from cracks, scratches, voids in the adhesive bond, and other anomalies; and concentric within the performance requirements.</p>
<p>SURFACE PITS</p> <p>Top View</p>  <p>Photo Image</p> 	<p>REJECT</p> <p>Reject/Repolish if in core or cladding.</p>
<p>SCRATCHES</p> <p>Top View</p>  <p>Photo Image</p> 	<p>REJECT</p> <p>Reject/Repolish if in core.</p>

Figure A-3. Fiber in Ferrule - Back-Lit

NASA-STD-8739.5A

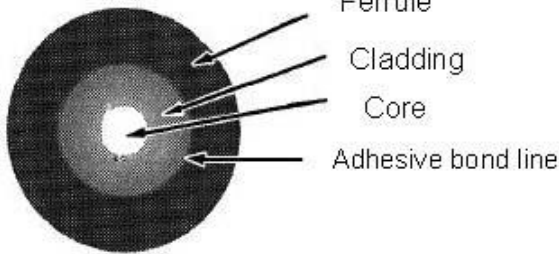
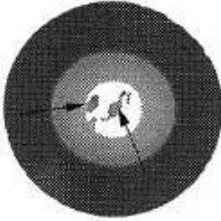

<p>CRACK</p> <p>Top View</p>  <p>Photo Image</p>  <p>*Ferrule not visible in photo</p>	<p>REJECT</p> <p>Reject.</p>
<p>EDGE CHIPS</p> <p>Top View</p>  <p>Photo Image</p>  <p>*Ferrule not visible in photo</p>	<p>REJECT</p> <p>May be fixable by polishing.</p>

Figure A-4. Fiber in Ferrule - Back-Lit - Continued

# NASA-STD-8739.5A

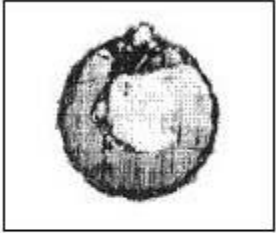

<p><b>PERFECT</b></p> <p>Top View</p>  <p>Ferrule</p> <p>Core and Cladding</p> <p>Photo Image</p>  <p>* Ferrule not visible in photo</p>	<p><b>ACCEPT</b></p> <p>Free from cracks, scratches, edge chips, hackles, pits, and other anomalies; and concentric within the performance requirements.</p> <p>Note: Cracks may be invisible without core illumination.</p>
<p><b>SURFACE PITS</b></p> <p>Top View</p>  <p>Photo Image</p>  <p>* Ferrule not visible in photo</p>	<p><b>REJECT</b></p> <p>Reject/Repolish if in core or cladding.</p> <p>Confirm by backlighting.</p>
<p><b>SCRATCHES</b></p> <p>Top View</p> 	<p><b>REJECT</b></p> <p>Reject/Repolish.</p>
<p><b>EPOXY</b></p> <p>Top View</p>  <p>Photo Image</p>  <p>* Ferrule not visible in photo</p>	<p><b>REJECT</b></p> <p>Reject if epoxy is on core, cladding or ferrule. May be fixable by repolishing.</p>

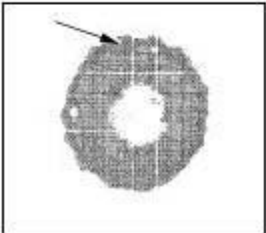
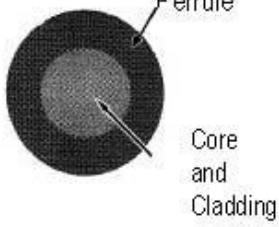
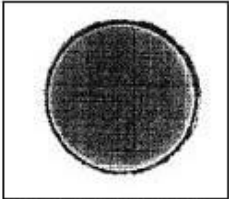
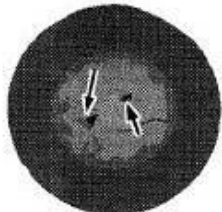
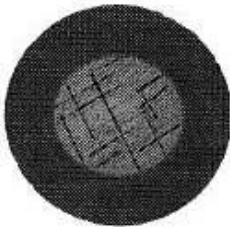
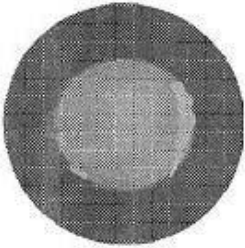
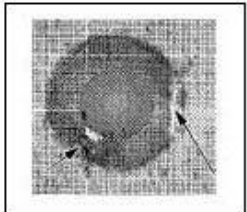
Figure A-5. Fiber in Ferrule - Direct-Lit, No Core Illumination