



National Aeronautics and  
Space Administration

MSFC-STD-3528  
REVISION E  
EFFECTIVE DATE: 10-JAN-2017

---

George C. Marshall Space Flight Center  
Marshall Space Flight Center, Alabama 35812

**EV32**

**MSFC TECHNICAL STANDARD**

**COMPUTER-AIDED DESIGN  
(CAD) STANDARD**

Approved for Public Release; Distribution Unlimited

CHECK THE MASTER LIST  
VERIFY THAT THIS IS THE CORRECT VERSION BEFORE USE

<b>MSFC Technical Standard EV32</b>		
<b>Title: Computer-Aided Design (CAD) Standard</b>	<b>Document No.: MSFC-STD-3528</b>	<b>Revision: Revision E</b>
	<b>Effective Date: 10-JAN-2017</b>	<b>Page 2 of 98</b>

## DOCUMENT HISTORY LOG

Status (Baseline/ Revision/ Canceled)	Document Revision	Effective Date	Description
Baseline	-	September 30, 2008	Initial release of document.
Revision	A	January 14, 2009	<p>General throughout: Changed "As-Manufactured" to "As-Designed".</p> <p>Section 3.1: Changed MKS for Meter Kilogram Second to mmKS for millimeter Kilogram Second</p> <p>Section 3.2: Inserted definition of Configuration Item and renumbered accordingly. Updated definition of End Item.</p> <p>Section 4.1.5.1 b: Changed Meter Kilogram Second (MKS) to millimeter Kilogram Second (mmKS).</p> <p>Section 4.1.6.1: Added "inches for English start parts and 0.00127 millimeters for metric start parts" to the end of the first sentence.</p> <p>Section 8.6.8 was: "A WT Part that is to be used outside of its product context is typically an "End Item" and will have a special WT Part object assigned. These end items are normally "Major Assemblies" such as an Aft Skirt or an Instrument Unit."</p> <p>Section 8.10.1: Inserted Latest Design as a Configuration and updated the definition for Latest, Latest Workgroup Approved, and Latest Released.</p> <p>Section 8.13.2: Updated role names. Replaced Specification Documents with Skeleton Files in 8.13.2.2.</p> <p>Section 8.13.3: Updated all Access by Lifecycle States information.</p> <p>Section 8.14: Updated Workgroup Approval information.</p> <p>Section 8.17: Updated requirements for Viewables.</p> <p>Section 12.10: Updated requirements regarding Named Views and Cross-Section Datums.</p> <p>Designer's Checklist: Updated C-21, C-22, A-15, and A-16 in accordance with Section 12.10 changes and made them N/A to Checkers. Deleted A-14.</p>
Revision	B	May 19, 2009	<p>Section 2 - Added Authority Documents to the title, made Authority Documents para. 2.1 and renumbered the remaining para.; Added (Draft) after CxP 72142 title. Assigned titles to Desktop Instructions ED-CAD-DI-025 and ED-CAD-DI-026.</p> <p>Section 3.2 - Added definitions for Common Parts and Standard Parts.</p> <p>Section 4.1.3.4 - Replaced "REV-" with "*" in the template file name, with "*" representing the latest revision.</p> <p>Section 4.2.4 - Added reference to ED-CAD-DI-026.</p> <p>Section 5.4.3 - Added -BULK1, -BULK2, etc. as a companion file type.</p> <p>Section 6.5.4.1 - Modified the Description, Part Number and Part Type parameter requirements.</p> <p>Section 6.8.1 - Added exceptions to the requirements for Bulk Items, and a reference to ED-CAD-DI-025.</p> <p>Section 7.2.2 - Added exceptions to 7.2.2.1. Added 7.2.2.3 to define the exceptions.</p> <p>Section 7.3, 8.1.4, 12.1.2.5, 13.6, Appendix B6, Designer's Checklist A-13 - Changed Standard Parts Library to Common Parts Library.</p> <p>Section 7.6.2 - Deleted.</p> <p>Section 8.6.12, 8.12.2, 8.13.1.3 - Deleted.</p> <p>Section 8.9.2 - Added "for assemblies or non-latest revisions of parts" to Item c.</p> <p>Section 12.1.2.1 Para. c. and 12.7.4 - Added " promoting the model to the "Design" state and prior to submitting the model for WGA or" before "release".</p> <p>Section 12.1.2.5 - Added "parts in flat or formed states" to the list for use of family tables. Added Sections 12.7.2.1 and 12.7.2.2 regarding feature and edge references.</p> <p>Section 12.13.5 - Added requirements regarding rounds and chamfer children. Changed Appendix B reference to 12.13.6.</p> <p>Appendix B - Corrected paragraph reference for B1, B6, B14. and B16. Deleted ModelCHECK errors and warning list from B2. Deleted B9, B12, and B13. Deleted "lifecycle" two places and the last bullet from B10.</p> <p>Appendix C - Deleted the Optimum Workstation Settings.</p>

**CHECK THE MASTER LIST  
VERIFY THAT THIS IS THE CORRECT VERSION BEFORE USE**

<b>MSFC Technical Standard EV32</b>		
<b>Title: Computer-Aided Design (CAD) Standard</b>	<b>Document No.: MSFC-STD-3528</b>	<b>Revision: Revision E</b>
	<b>Effective Date: 10-JAN-2017</b>	<b>Page 3 of 98</b>

			<p>Appendix D - Added C-25 to check for round and chamfer children. Added reference to ED-CAD-DI-025 to A-7.</p> <p>Appendix E - Assigned titles to Desktop Instructions ED-CAD-DI-025 and ED-CAD-DI-026.</p>
Revision	C	February 08, 2010	<p>Changed the Office of Primary Responsibility from EV83 to EV32.</p> <p>Section 2.1 - Corrected the document number and title.</p> <p>Section 2.3 - Inserted ED-OWI-005 and renumbered; changed the title of Desktop Instruction ED-CAD-DI-014 to Cable Routing; added six new Desktop Instructions at the end of the list.</p> <p>Section 3.2 - Updated the definitions of Effectivity, Hpgl Format, and WT Part.</p> <p>Section 4.1.3.4 - Corrected the template names and clarified the meaning of the “**”.</p> <p>Section 4.3.3.1 - Added an exception and the appropriate reference within the document regarding composite views.</p> <p>Section 5.4.3 - Added -PATL as a companion file extension for partial assemblies.</p> <p>Section 5.5 - Added requirements from NASA-STD-(I)-0007 for the file name.</p> <p>Section 6.5.4.2 - Changed “FABRICATION” to “NEXTASSY” and reordered the listing in the tables to match the order the designer fills them out.</p> <p>Section 6.7.2 - Updated the requirements for the OML rep and added requirements for a Graphics rep.</p> <p>Section 6.7.3.1.d – Clarified that fasteners are included in SIMPLE rep.</p> <p>Section 7.2.2 - Added note requirements for Altered Item, Source Control, Vendor Item Control, and Envelope drawings.</p> <p>Section 8.9, 8.10 - Updated the requirements for Managed Baselines.</p> <p>Section 8.10, 8.13, 8.14 - Changed “design data” to CAD and “WT Parts”.</p> <p>Section 8.10.1.5 - Added reference to ED-CAD-DI-030.</p> <p>Section 8.13.3.1 - Updated Access to include CAD-WT Part In Work-Read Only.</p> <p>Section 8.15.1.1 - Added reference to ED-OWI-005.</p> <p>Section 12.16.3 - Change DI title to Cable Routing.</p> <p>Section 12.22 - Added additional requirements for Composite Parts.</p> <p>Section 12.23, 13.13 - Added new requirement for Layouts.</p> <p>Section 13.12 - Added new requirements for Large File Management and Partial Assemblies.</p> <p>Section 14.3.8 - Added the exception of adding a new dash number to existing released design data and re-formatted the section to use bullets.</p> <p>Section 14.3.9 - Modified the requirement to reflect that every drawing has an EPL.</p> <p>Section 14.3.11 - Added new section to add requirements for Drawings of Composites.</p> <p>Section 14.4.2 - Added details for drawing notes for other types of drawings added in Section 7.2.2.</p> <p>Section 14.4.5 - Changed “shall” to “should” regarding use of Standard Notes.</p> <p>Section 14.6.2 - Changed the viewable format from hpgl to pdf.</p> <p>Appendix D - Added reference to Paragraph 14.3.8 to C-13. Added C-26 through C-29. Modified D-7 and D-14 to be consistent with new requirements. Added D-17 through D-19.</p> <p>Appendix E - Changed the title of Desktop Instruction ED-CAD-DI-014 to Cable Routing; added two new Desktop Instructions at the end of the list.</p>
Revision	D	August 18, 2011	<p>Section 1.1.4 – Added “and parts list” after drawing.</p> <p>Section 1.1.9 – Corrected the web address for Pro/ENGINEER Tips and Techniques.</p> <p>Section 2.2 – Deleted CxP 72142 from the list of Required Documents.</p> <p>Section 2.3, Appendix E – Added Desktop Instructions ED-CAD-DI-031, -032, -033, -034, -035, -036.</p> <p>Section 3.1 – Deleted CLV, DAC, IE, PIM from the Acronym list.</p> <p>Section 3.2 – Updated definitions of Baseline, Inseparable Assembly, Mono-detail Drawing, and added definitions for Bottom-Up Design Methodology, DDMS Baseline, Design Layout Drawing, Modular Product Architecture, Pro/ENGINEER Layout, and Top-Down Design Methodology. Deleted Hpgl from the list.</p> <p>Section 4.1.5.1 – Changed dashes in Start Part file names to underbars.</p> <p>Section 4.2.4 – Added reference to ED-CAD-DI-026 for acceptable exceptions to ModelCHECK errors.</p> <p>Section 5.1.2.1 Table 2 – Added file extension information to Number field.</p> <p>Section 5.2.2 – Replaced “Part Number” with “Dash Number”.</p>

**CHECK THE MASTER LIST  
VERIFY THAT THIS IS THE CORRECT VERSION BEFORE USE**

<b>MSFC Technical Standard EV32</b>		
<b>Title: Computer-Aided Design (CAD) Standard</b>	<b>Document No.: MSFC-STD-3528</b>	<b>Revision: Revision E</b>
	<b>Effective Date: 10-JAN-2017</b>	<b>Page 4 of 98</b>

		<p>Section 5.2.2.7 – Replaced “Part Number” with “Dash Number”; replaced MFSC-STD-555 with ED-OWI-005; deleted item d.</p> <p>Section 5.3.1.1 Table 3 – Updated information for Filename and Number.</p> <p>Section 5.3.1.2 – Inserted “base” after “Final”.</p> <p>Section 5.3.1.3 – Replaced final CAD file name requirement with requirement for who assigns the dash number.</p> <p>Section 5.3.1.4 – Added -101, etc., for dash numbers for inseparable assemblies.</p> <p>Section 5.4.1 – Changed “Companion Files...” to “Companion CAD Files...”.</p> <p>Section 5.4.3 – Updated descriptions for ENV, LAY, and REL companion files.</p> <p>Section 5.6 – Updated requirements to change from WGA Promotion Notice to WGA CR; deleted the option of the drawing number for multiple assemblies being in the name.</p> <p>Section 5.7.2 – Added.</p> <p>Section 6.5.4.2 – Changed the drawing parameter name from “NEXTASSY” to “NEXTHIGHER”.</p> <p>Section 6.7.2.1.d – Added “shaded” in front of GRAPHICS in (1) and (2).</p> <p>Section 6.7.3.1.a – Added item (3).</p> <p>Section 6.7.3.1.e – Updated (1) and (2).</p> <p>Section 7.2.2.1 – Added “schematics, etc. to the list of exceptions.</p> <p>Section 7.2.2.5 – Changed “Approved” to “Suggested” in item 4.</p> <p>Section 7.2.2.6 – Added “schematics” after “Envelope”.</p> <p>Section 7.2.2.7 – Added.</p> <p>Section 7.3.5 – Deleted.</p> <p>Section 8.2.3 – Added reference to ED-CAD-DI-033 and ED-CAD-DI-035.</p> <p>Section 8.4.1 – Added reference to ED-CAD-DI-032.</p> <p>Section 8.8.1.3 – Deleted “mono-detail”.</p> <p>Section 8.9, 8.10, Appendix B – Change “Managed Baseline” to “DDMS Baseline”.</p> <p>Section 8.11.4 – Added.</p> <p>Section 8.13.3.6 – Inserted “Rework” state and renumbered “Released” state.</p> <p>Section 8.14.1 – Changed “promotion” to “CR”.</p> <p>Section 8.15.1.1 – Added reference to ED-CAD-DI-036.</p> <p>Section 8.17.2 – Deleted references to solid geometry and managed baseline.</p> <p>Section 9 – Changed section from “Top Down Design Methodology” to “Design Methodology”.</p> <p>Section 10 – Changed section from “SPECIFIC GUIDELINES FOR TDD INTEGRAL METHODOLOGY AND CONTROL STRUCTURE” to “BOTTOM-UP DESIGN METHODOLOGY”.</p> <p>Section 11 – Rewrote the requirements regarding Modular Product Architecture and moved old information to ED-CAD-DI-034.</p> <p>Section 12.1.2.1.c – Updated wording to apply to Copy Geometry features</p> <p>Section 12.1.2.1.d – Added.</p> <p>Section 12.4 – Corrected the numbering of the sub-sections.</p> <p>Section 12.7.3 – Added “something logical and meaningful to the designer” as the naming criteria.</p> <p>Section 12.7.4 – Added to delete dependencies prior to release.</p> <p>Section 12.8.2 – Added “or missing details” to the end of the requirement.</p> <p>Section 12.18 – Updated requirements for UDFs.</p> <p>Section 12.22 – Added “or surface” to requirements for boundary curves.</p> <p>Section 12.23 – Added requirements for Pro/ENGINEER layouts.</p> <p>Section 12.24 – Added requirements for Envelope Models.</p> <p>Section 13.3.2 – Added requirement regarding Design State and WGA, and to delete prior to release.</p> <p>Section 13.4.1 – Replaced “etc.” with “or any other feature that removes material.”</p> <p>Section 13.14 – Added requirements for Inseparable Assemblies.</p> <p>Section 14.2.2 – Added exception for drawings of 2D geometry and Kit Drawings.</p> <p>Section 14.3.6 – Added “common” between “insert symbols.”</p> <p>Section 14.3.8 Clarified that mono-detail applies to assembly drawings and deleted the last bullet. Added reference to Section 13.14.</p> <p>Section 14.3.13 – Added requirements for Kit Drawings.</p> <p>Section 14.3.14 – Added requirements for Design Layout Drawings.</p>
--	--	---

**CHECK THE MASTER LIST  
VERIFY THAT THIS IS THE CORRECT VERSION BEFORE USE**

<b>MSFC Technical Standard EV32</b>		
<b>Title: Computer-Aided Design (CAD) Standard</b>	<b>Document No.: MSFC-STD-3528</b>	<b>Revision: Revision E</b>
	<b>Effective Date: 10-JAN-2017</b>	<b>Page 5 of 98</b>

			<p>Section 14.3.15 – Added requirements for Envelope/Vendor Item Control/Source Control Drawings.</p> <p>Section 14.4.1 – Added exception for 2D drawings and Kit drawings.</p> <p>Appendix B1 – Changed “increased” to “adjusted” in the first sentence and deleted the last sentence.</p> <p>Appendix B3, B15 – Deleted.</p> <p>Appendix B14 – Changed “hpgl” to pdf”.</p> <p>Appendix D – Updated C-4, C-6, C-15, C-16, C-25, C-26, C-27, C-28, A-1, A-2, A-11, D-2, D-3.</p> <p>Appendix D – Deleted C-20.</p> <p>Appendix D – Added C-30, A-19, W-6.</p> <p>Appendix E – Added six Desktop Instructions to the end of the list.</p>
Revision	E	10--JAN-2017	<p>General throughout: Changed “Pro/ENGINEER” to “Creo Parametric”, and “DDMS” to “ICE Windchill”. Updated trademark information. Added headers to tables. Changed filename to two words.</p> <p>Section 1 – Deleted the last sentence to remove addressing other CAD tools.</p> <p>Section 1.1.1 – Added “legacy” before “Ground Support Equipment”, and added a second sentence requiring GSE which interfaces with flight hardware to adhere to this document.</p> <p>Section 1.1.2 – Added “for non-flight hardware” after GSE.</p> <p>Section 1.1.9 – Deleted and renumbered following sections.</p> <p>Section 1.1.10 – Replaced the DDMS website with the ICE Windchill website.</p> <p>Section 2 – Changed “Authority” to “Authoritative” and “Required” to “Applicable” and added first paragraph.</p> <p>Section 2.2 – Replaced “H Para. 4.3.8” with “J” for MSFC-STD-555.</p> <p>Section 2.3 – Deleted b. through f. and renumbered.</p> <p>Section 3 – Updated Acronyms.</p> <p>Sections 4 and 14 – Changed “Guidelines” to “Requirements”.</p> <p>Section 4.1.4.5, 4.4.1.6 – Deleted and renumbered following sections.</p> <p>Section 4.1.4.7 – Defined how to over-ride the drawing format title block tolerances.</p> <p>Section 4.2 – Changed running ModelCHECK prior to WGA from a requirement to a best practice.</p> <p>Section 4.3.1 – Added references to ASME Y14.5M-1994 and ASME Y14.41-2003.</p> <p>Section 5.1.1 – Updated the figures.</p> <p>Section 5.2.1 – Changed the initial CAD file name to be less restrictive.</p> <p>Figure 1 and Section 5.3.1 – Deleted “Design Software”.</p> <p>Section 5.3.1.1 Table 3 – Clarified that there is no dash number for the 2D drawing file name for tabulated and non-part drawings such as schematics.</p> <p>Section 5.3.1.4 – Added “as an inseparable assembly in Section 13.14.1”.</p> <p>Section 5.4.1, 5.4.3, 8.8, 14.3.14.2, Appendix D W-2 – Changed “active” to “primary”.</p> <p>Section 5.4.3 – Added ACM1, ICM1, and IDP1 as companion file types. Moved BULK1 to make the list alphabetical.</p> <p>Section 5.6.2, 5.6.3 – Change “IEC” to “NASA”.</p> <p>Section 5.6.3.2 – Deleted the requirement to have the CR number in the name.</p> <p>Section 5.7.2, Appendix D C-6, A-2, D-3, W-6 – Deleted the requirement that the designer had to delete the extension.</p> <p>Section 6.1.1.4 – Added requirement to hide all layers if possible.</p> <p>Section 6.5.4.1, 6.5.4.2 – Updated all the parameter information.</p> <p>Section 6.7.2.1 – Changed “simplified reps” to “representation”. Deleted GRAPHICS reps and made SIMPLE and OML reps a best practice in a new Section 6.7.2.2.</p> <p>Section 6.7.3.1 – Moved the last three reps to a new Section 6.7.3.2 and made them a best practice.</p> <p>Section 6.8.1 – Added –BULK clarification and cotter pins as an exception for bulk items with CAD.</p> <p>Section 7.2.2.2 – Added Fastener Procurement to the Common Notes list.</p> <p>Section 7.2.3 – Added “Selecting Not Applicable will place “RESERVED” as the text for that note.” as the second sentence.</p> <p>Section 7.3.1 – Deleted “for the entire vehicle” and moved “common” before “parts” in the first sentence.</p> <p>Section 7.6 – Corrected the Config.win file name.</p>

**CHECK THE MASTER LIST  
VERIFY THAT THIS IS THE CORRECT VERSION BEFORE USE**

<b>MSFC Technical Standard EV32</b>		
<b>Title: Computer-Aided Design (CAD) Standard</b>	<b>Document No.: MSFC-STD-3528</b>	<b>Revision: Revision E</b>
	<b>Effective Date: 10-JAN-2017</b>	<b>Page 6 of 98</b>

			<p>Section 8.6.5, 8.6.6, 8.15.2, 12.24.4 – Changed “active” to “owner” association”.  Section 8.6.7, 8.8.2.1 through 8.8.2.5, 8.15.2, 12.24.4, Appendix D W-4, W-5 – Changed “passively” associated” to “have a “content” association”.</p> <p>Section 8.6.11 – Deleted.</p> <p>Section 8.9.3, 8.10.2 – Changed the reference to the DDMS User’s Guide module to the MSFC CAD library in ICE Windchill.</p> <p>Section 8.7 – Changed the section to refer to “ICE Windchill Relationships Built Through Product Structure”.</p> <p>Section 8.8.2.5 – Changed “shall NOT” to “may not” and added “Refer to MSFC-STD-555 Appendix I2.1 for when a WT Part is required.”</p> <p>Section 8.10.1.3 through 8.10.1.6a – Added “This is a manual process performed by the designer.”</p> <p>Section 1.1.4, 3.2, 8.1.1, 8.11, 14.3.13.3 – Added “engineering” before “parts list” or substituted “EPL” for “parts list”.</p> <p>Section 8.13.2, 8.13.3 – Updated the access role titles and added new roles.</p> <p>Section 8.14.1 – Deleted the reference to the User’s Guide Module.</p> <p>Section 8.15.1.1 – Replaced reference to OWI with MSFC-STD-555 Section 4.6.2.</p> <p>Section 8.18 – Updated the title and content for expedited changes.</p> <p>Section 9.1.2.2, 11.1.1, 11.4.4, 12.1.2.1c, 12.7.4, 13.3.2, Appendix D C-16, C-30 and A-19 – Changed from breaking/deleting/toggling external references to setting them to “Independent.”</p> <p>Section 10.1 – Changed “Pro/PIPING” to “Creo Piping” and “Pro/CABLING” to “Creo Cabling”.</p> <p>Section 11.1.2 – Deleted.</p> <p>Section 11.3.3 – Changed to “An interface control skeleton shall control only one interface.”</p> <p>Section 11.4.1 – Added “except for bolt hole pattern axes” to the end.</p> <p>Section 11.4.3 – Changed to “One skeleton shall NOT be used for more than one routed line.”</p> <p>Section 11.4.4 – Deleted “Reference viewer or”.</p> <p>Section 12.1.2.5 – Added a reference to ED-CAD-DI-013.</p> <p>Section 12.20.1 – Added –MOD clarification.</p> <p>Section 12.20.2 – Added a reference to ED-CAD-DI-031.</p> <p>Section 12.22.2 – Added “normal” after “projected”.</p> <p>Section 12.22.2, 12.22.3, 12.22.4 – Deleted “or surface” from the first sentence.</p> <p>Section 12.22.3, 12.22.4 – Added a note at the end.</p> <p>Section 13.6.1 – Replaced “program approved” with “library”.</p> <p>Section 13.7, 13.9.1 – Changed “shall” to “should”.</p> <p>Sections 13.7.2, 13.7.3 – Updated the statements to be consistent with 12.10.</p> <p>Sections 13.14.1, 13.14.2 – Reversed the order.</p> <p>Section 13.14.1 – Added “but not required” after allowed and “inseparable assembly” before drawing in the first sentence. Added details to a. through d. for numbering, drawings, and WT Parts.</p> <p>Section 13.14.2 – Added “inseparable assembly” before drawing in the first sentence. Added “or bonded assemblies” after “Weldments” and replaced “weld” with “process” in b. Added reference to 13.14.1. to b and c.</p> <p>Section 14.1.2 – Changed the standard font from msfc02.fnt to CG Triumvirate on new drawings. Added statements regarding existing drawings and consistent font within a drawing. Added a note to refer to Section 4.1.3.4 regarding font.</p> <p>Section 14.1.3 – Added “Axonometric views shall NOT be dimensioned.”</p> <p>Section 14.3.8 – Changed “Table driven” to “Family Table driven/tabulated”. Added reference to Section 12.1.2.5.</p> <p>Section 14.3.9 – Added “that requires an EPL” to the first sentence.</p> <p>Section 14.3.10 – Deleted and renumbered the following sections.</p> <p>Section 14.3.11.2 – Changed “on” to “for”.</p> <p>Section 14.3.13.3 – Allowed the Kit drawing to be on the parts list as reference.</p> <p>Appendix A – Change the title and changed “has” to “can have” in the first sentence.</p> <p>Appendix D – Corrected the function in C-1. Deleted SIMPLE and OML from C-12. Added “as needed” to A-6. Updated exceptions in A-7. Updated D-18 for rosette.</p>
--	--	--	--

**CHECK THE MASTER LIST  
VERIFY THAT THIS IS THE CORRECT VERSION BEFORE USE**

<b>MSFC Technical Standard</b>		
<b>EV32</b>		
<b>Title: Computer-Aided Design (CAD) Standard</b>	<b>Document No.: MSFC-STD-3528</b>	<b>Revision: Revision E</b>
	<b>Effective Date: 10-JAN-2017</b>	<b>Page 7 of 98</b>

**TABLE OF CONTENTS**

<b>PARAGRAPH</b>	<b>PAGE</b>
<b>1. SCOPE/PURPOSE .....</b>	<b>12</b>
1.1 Application.....	12
<b>2. AUTHORITATIVE AND APPLICABLE DOCUMENTS .....</b>	<b>13</b>
2.1 Authoritative Documents .....	13
2.2 Applicable Documents.....	13
2.3 Reference Documents .....	13
<b>3. ACRONYMS/DEFINITIONS .....</b>	<b>14</b>
3.1 Acronyms .....	14
3.2 Definitions.....	15
<b>4. GENERAL REQUIREMENTS.....</b>	<b>18</b>
4.1 Default Settings.....	18
4.1.1 Start Part.....	18
4.1.2 Start Assembly .....	18
4.1.3 Start Drawing/Drawing Template.....	19
4.1.4 Dimensional and Angular Tolerances.....	19
4.1.5 Systems of Units .....	20
4.1.6 Part Accuracy.....	20
4.2 Model and Drawing Integrity .....	20
4.3 General Drafting Requirements .....	21
<b>5. NAMING CONVENTION.....</b>	<b>22</b>
5.1 Initial CAD Identification .....	22
5.1.1 Initial Creo Parametric CAD Name, Common Name, and File Name .....	22
5.1.2 Initial ICE Windchill CAD Number, Name, and File Name .....	23
5.2 Initial CAD File Name.....	24
5.3 Final CAD Identification for “As-Designed” Model.....	24
5.3.1 Final ICE Windchill and Creo Parametric CAD Identification .....	24
5.4 Companion CAD File Identification.....	26
5.5 CAD File Name for Vendor Parts.....	27
5.6 Numbering and Naming of ICE Windchill Baseline and Change Requests (CRs) for WGA and Other Release.....	28
5.6.1 ICE Windchill Baseline Numbering and Naming .....	28
5.6.2 ICE Windchill CR Numbering and Naming for WGA.....	28
5.6.3 ICE Windchill CR Numbering and Naming for Release.....	29
5.7 WT Part Identification .....	30

**CHECK THE MASTER LIST  
VERIFY THAT THIS IS THE CORRECT VERSION BEFORE USE**

<b>MSFC Technical Standard</b>		
<b>EV32</b>		
<b>Title: Computer-Aided Design (CAD) Standard</b>	<b>Document No.: MSFC-STD-3528</b>	<b>Revision: Revision E</b>
	<b>Effective Date: 10-JAN-2017</b>	<b>Page 8 of 98</b>

**TABLE OF CONTENTS**  
**(Continued)**

<b>PARAGRAPH</b>	<b>PAGE</b>
<b>6. STANDARD PRACTICES .....</b>	<b>30</b>
6.1 Layers .....	30
6.1.1 Layer Usage .....	30
6.1.2 Default Layers.....	31
6.2 Colors .....	32
6.3 Materials .....	32
6.4 Mass Properties .....	33
6.5 Parameters .....	33
6.6 Relations .....	36
6.7 Simplified Representations .....	37
6.7.1 Use of Simplified Representations.....	37
6.7.2 Part Simplified Representations.....	37
6.7.3 Assembly Simplified Representations .....	37
6.8 Bulk Items .....	38
<b>7. STANDARDIZATION .....</b>	<b>38</b>
7.1 Settings and Scripts.....	38
7.2 Standard Notes List.....	39
7.3 Common Parts Library.....	40
7.4 Symbol Library .....	41
7.5 Startup Script .....	41
7.6 Configuration Settings .....	41
<b>8. PRODUCT LIFECYCLE MANAGEMENT USING ICE WINDCHILL .....</b>	<b>42</b>
8.1 ICE Windchill .....	42
8.2 CAD Entry into ICE Windchill.....	42
8.3 CAD Document and CAD Structure Creation in ICE Windchill .....	42
8.4 ICE Windchill Product Areas .....	43
8.5 ICE Windchill CAD Object Versions (Revisions/Iterations) .....	43
8.5.1 Version Schemes.....	43
8.5.2 Numeric Version Scheme .....	43
8.5.3 Alpha-Numeric Version Scheme .....	43
8.6 ICE Windchill Product Structure .....	44
8.7 ICE Windchill Relationships Built Through Product Structure .....	45
8.8 WT Part Digital Data Sets.....	45
8.8.1 Primary Model (“As-Designed”) .....	45
8.8.2 Related Models .....	45
8.9 ICE Windchill Baselines .....	46
8.10 Configurations (Options for Gathering Data within ICE Windchill) .....	46
8.10.1 Description of Configuration for Designers .....	46

**CHECK THE MASTER LIST**  
**VERIFY THAT THIS IS THE CORRECT VERSION BEFORE USE**



<b>MSFC Technical Standard</b>		
<b>EV32</b>		
<b>Title: Computer-Aided Design (CAD) Standard</b>	<b>Document No.: MSFC-STD-3528</b>	<b>Revision: Revision E</b>
	<b>Effective Date: 10-JAN-2017</b>	<b>Page 9 of 98</b>

**TABLE OF CONTENTS**  
**(Continued)**

<b>PARAGRAPH</b>	<b>PAGE</b>
8.11 Engineering Parts List.....	48
8.12 Lifecycle Scheme.....	48
8.13 Access Methodology.....	48
8.13.1 General Requirements.....	48
8.13.2 Access by Folder.....	48
8.13.3 Access by Lifecycle State.....	49
8.14 Workgroup Approval (WGA).....	50
8.15 Release.....	50
8.15.1 Initiation.....	50
8.15.2 Initial Release.....	51
8.15.3 Changes to Released Design.....	51
8.16 Security (SBU).....	51
8.17 Viewables.....	51
8.18 Expedited Changes to Released Data.....	52
<b>9. DESIGN METHODOLOGY .....</b>	<b>52</b>
9.1 Guidelines for Selecting Design Methodology.....	52
<b>10. BOTTOM-UP DESIGN METHODOLOGY .....</b>	<b>52</b>
<b>11. MODULAR PRODUCT ARCHITECTURE (MPA) .....</b>	<b>53</b>
11.1 General Requirements.....	53
11.2 Locator Skeletons.....	53
11.3 Interface Control Skeletons.....	53
11.4 Model Requirements.....	53
<b>12. PART MODELING .....</b>	<b>54</b>
12.1 Modeling Requirements.....	54
12.2 Design Intent.....	55
12.3 Part Initialization.....	55
12.4 Model Creation.....	55
12.5 Sketcher.....	56
12.6 Part/Sketcher Relations.....	56
12.7 Feature References.....	56
12.8 Feature Modification/Verification.....	57
12.9 Part Assembly Datums.....	57
12.10 Named Views and Cross-Section Datums.....	57
12.11 Family Tables.....	57
12.12 Holes.....	58
12.13 Rounds and Chamfers.....	58

**CHECK THE MASTER LIST**  
**VERIFY THAT THIS IS THE CORRECT VERSION BEFORE USE**

<b>MSFC Technical Standard</b>		
<b>EV32</b>		
<b>Title: Computer-Aided Design (CAD) Standard</b>	<b>Document No.: MSFC-STD-3528</b>	<b>Revision: Revision E</b>
	<b>Effective Date: 10-JAN-2017</b>	<b>Page 10 of 98</b>

**TABLE OF CONTENTS**  
**(Continued)**

<b>PARAGRAPH</b>	<b>PAGE</b>
12.14 Drafts.....	59
12.15 Castings and Forgings.....	59
12.16 Piping/Cabling .....	59
12.17 Sheet Metal .....	59
12.18 User Defined Features (UDF).....	59
12.19 Gears, Splines and Sprockets.....	60
12.20 Variable Geometry Components.....	60
12.21 Pro/PROGRAM™ .....	60
12.22 Composite Parts .....	60
12.23 Creo Parametric Layouts.....	61
12.24 Envelope Models .....	61
<b>13. ASSEMBLY MODELING .....</b>	<b>62</b>
13.1 Start Assembly.....	62
13.2 Skeleton Parts.....	62
13.3 Assembly Level Dependencies .....	62
13.4 Assembly Created Features.....	62
13.5 Component Placement Constraints .....	63
13.6 Common Parts.....	63
13.7 Named Views and Cross-Section Datum Planes .....	63
13.8 Related Level Drawing Model.....	64
13.9 Shrinkwrap™ Files .....	64
13.10 Exploded Views .....	64
13.11 Extraneous Entities .....	64
13.12 Large File Management .....	64
13.12.1 Partial Assemblies.....	64
13.13 Layouts.....	65
13.14 Inseparable Assemblies.....	65
<b>14. DRAWING REQUIREMENTS .....</b>	<b>66</b>
14.1 Drawing Standards.....	66
14.2 Drawing Template and Format .....	66
14.3 Drawing Content and Types of Drawings .....	66
14.4 Drawing Notes .....	69
14.5 Tabulated Drawing.....	69
14.6 Drawing Information from ICE Windchill .....	69

**CHECK THE MASTER LIST**  
**VERIFY THAT THIS IS THE CORRECT VERSION BEFORE USE**

<b>MSFC Technical Standard EV32</b>		
<b>Title: Computer-Aided Design (CAD) Standard</b>	<b>Document No.: MSFC-STD-3528 Effective Date: 10-JAN-2017</b>	<b>Revision: Revision E Page 11 of 98</b>

APPENDIX A Initial Naming Convention Example .....71  
APPENDIX B Additional Information For Reference Only.....74  
APPENDIX C (Deleted) .....81  
APPENDIX D Designer’s Checklist .....82  
APPENDIX E List of Desktop Instructions.....97  
APPENDIX F Recommended Hole Sizes .....98

**LIST OF FIGURES**

<b>FIGURE NO.</b>	<b>PAGE</b>
Figure 1. Creo Parametric Name Entry Interface .....	23
Figure 2. ICE Windchill Name Entry Interface .....	24

**LIST OF TABLES**

<b>TABLE NO.</b>	<b>PAGE</b>
Table 1. Creo Parametric CAD Initial Naming Requirements .....	22
Table 2. ICE Windchill CAD Initial Numbering/Naming Requirements.....	23
Table 3. ICE Windchill CAD Final Numbering/Naming Requirements .....	25
Table 4. Companion File Extensions .....	26
Table 5. ICE Windchill WT Part Identification Requirements.....	30
Table 6. Part/Assembly Parameters .....	34
Table 7. Drawing Parameters.....	34
Table 8. Drawing Approval/Release Parameters .....	35

**CHECK THE MASTER LIST  
VERIFY THAT THIS IS THE CORRECT VERSION BEFORE USE**

<b>MSFC Technical Standard EV32</b>		
<b>Title: Computer-Aided Design (CAD) Standard</b>	<b>Document No.: MSFC-STD-3528</b>	<b>Revision: Revision E</b>
	<b>Effective Date: 10-JAN-2017</b>	<b>Page 12 of 98</b>

## 1. SCOPE/PURPOSE

This document establishes the requirements and procedures for the creation and modification of Creo Parametric® (formerly called Pro/ENGINEER®) design software Computer-Aided Design (CAD) models and drawings for use at MSFC. The goal is to produce robust models that relate correct dimensional data directly to manufacturing processes. This document identifies modeling methodology so that all design groups produce consistent electronic deliverables within MSFC.

### 1.1 Application

1.1.1 All Creo Parametric objects created at MSFC **shall** adhere to the practices described within this document, except legacy Ground Support Equipment (GSE), Special Test Equipment (STE), and other non-flight hardware development entities which typically utilize existing or modified legacy hardware. GSE which interfaces with flight hardware and must be released through the MSFC release system as defined in MSFC-STD-555 **shall** adhere to the practices described within this document.

1.1.2 GSE for non-flight hardware, STE, and other non-flight hardware development entities should use this standard as a guide for modeling practices and adhere to it wherever practical.

1.1.3 The solid geometry in the CAD model **shall** be the authority, supplemented by 2-Dimensional (2D) drawings.

1.1.4 The drawing and Engineering Parts List (EPL) **shall** be used to define the notes, Geometric Dimensioning and Tolerancing (GD&T), and other information necessary to fully define the configuration.

1.1.5 Full Model Based Definition (MBD) will be addressed in a future appendix or revision to this document. All model annotations and tolerances until full MBD is implemented **shall** be ignored for manufacturing and quality assurance purposes.

1.1.6 This document will be applicable to all subcontractors preparing Creo Parametric models that will be integrated into MSFC designs.

1.1.7 The Designer's Checklist in Appendix D **shall** be used to check design packages for compliance with this Standard.

1.1.8 Models **shall** meet the Designer's Checklist in Appendix D.

1.1.9 Information regarding the Integrated Collaborative Environment (ICE) Windchill® can be found at the following website: <https://nasa-ice.nasa.gov/portal/> Refer to Desktop Instruction ED-CAD-DI-001, Workspace Use and Troubleshooting, for additional information.

**CHECK THE MASTER LIST  
VERIFY THAT THIS IS THE CORRECT VERSION BEFORE USE**

<b>MSFC Technical Standard EV32</b>		
<b>Title: Computer-Aided Design (CAD) Standard</b>	<b>Document No.: MSFC-STD-3528</b>	<b>Revision: Revision E</b>
	<b>Effective Date: 10-JAN-2017</b>	<b>Page 13 of 98</b>

1.1.10 Desktop Instructions (DIs) provide specific information on implementation techniques for certain requirements within the Standard and are listed in Appendix E. These DIs can be found at the Engineering Directorate Operational Instruction website: [https://masterlist.msfc.nasa.gov/lvl4\\_queries\\_new/iso9000\\_level4.taf?function=search](https://masterlist.msfc.nasa.gov/lvl4_queries_new/iso9000_level4.taf?function=search)

## **2. AUTHORITATIVE AND APPLICABLE DOCUMENTS**

### 2.1 Authoritative Documents

- |    |                   |   |
|----|-------------------|---|
| a. | NASA-STD-(I)-0007 | NASA Computer-Aided Design Interoperability |
|----|-------------------|---|

### 2.2 Applicable Documents

- |    |                     |   |
|----|---------------------|---|
| a. | MSFC-STD-555 Rev. J | MSFC Engineering Documentation Standard                         |
| b. | MSFC-STD-2806       | MSFC Tailoring Guide for the Global Drawing Requirements Manual |
| c. | Global Engineering  | Drawing Requirements Manual 10 <sup>th</sup> Edition            |
| d. | ASME Y14.100 – 2000 | Engineering Drawing Practices                                   |
| e. | ASME Y14.41 – 2003  | Digital Product Definition Data Practices                       |

### 2.3 Reference Documents

- |    |                                   |  |
|----|-----------------------------------|--|
| a. | ASME Y14.5M – 1994                | Dimensioning and Tolerancing                       |
| b. | Desktop Instruction ED-CAD-DI-001 | Workspace Use and Troubleshooting                  |
| c. | Desktop Instruction ED-CAD-DI-002 | Naming and Renaming Files in ICE Windchill         |
| d. | Desktop Instruction ED-CAD-DI-003 | Library Components                                 |
| e. | Desktop Instruction ED-CAD-DI-004 | Standard Drawing Notes                             |
| f. | Desktop Instruction ED-CAD-DI-005 | Simplified Representation Creation and Maintenance |
| g. | Desktop Instruction ED-CAD-DI-006 | Creation of Skeleton Files                         |
| h. | Desktop Instruction ED-CAD-DI-007 | Standard Symbols                                   |
| i. | Desktop Instruction ED-CAD-DI-008 | Updating Drawing Formats                           |
| j. | Desktop Instruction ED-CAD-DI-009 | MOD File Creation                                  |
| k. | Desktop Instruction ED-CAD-DI-010 | Shrinkwrap Creation                                |
| l. | Desktop Instruction ED-CAD-DI-011 | Data Transfer                                      |
| m. | Desktop Instruction ED-CAD-DI-012 | Casting and Forging Creation                       |
| n. | Desktop Instruction ED-CAD-DI-013 | Standard Barrel Panels                             |
| o. | Desktop Instruction ED-CAD-DI-014 | Cable Routing                                      |
| p. | Desktop Instruction ED-CAD-DI-015 | Piping   |
| q. | Desktop Instruction ED-CAD-DI-016 | Related Companion Files                            |
| r. | Desktop Instruction ED-CAD-DI-017 | Creating Standard Layers                           |
| s. | Desktop Instruction ED-CAD-DI-018 | Sheet Metal Parts                                  |
| t. | Desktop Instruction ED-CAD-DI-019 | Adding Materials and Generating Mass Properties    |
| u. | Desktop Instruction ED-CAD-DI-020 | User-Defined Features                              |
| v. | Desktop Instruction ED-CAD-DI-021 | Gears, Splines, and Sprockets                      |

**CHECK THE MASTER LIST  
VERIFY THAT THIS IS THE CORRECT VERSION BEFORE USE**

<b>MSFC Technical Standard EV32</b>		
<b>Title: Computer-Aided Design (CAD) Standard</b>	<b>Document No.: MSFC-STD-3528</b>	<b>Revision: Revision E</b>
	<b>Effective Date: 10-JAN-2017</b>	<b>Page 14 of 98</b>

- w. Desktop Instruction ED-CAD-DI-022 Vendor Item Modeling
- x. Desktop Instruction ED-CAD-DI-023 Exploded Views
- y. Desktop Instruction ED-CAD-DI-024 Tables and Tabulated Drawings
- z. Desktop Instruction ED-CAD-DI-025 Bulk Items
- aa. Desktop Instruction ED-CAD-DI-026 Verifying 3-Dimensional CAD Models
- ab. Desktop Instruction ED-CAD-DI-027 Revising CAD Documents and WT Parts
- ac. Desktop Instruction ED-CAD-DI-028 Physical Interface Matrix Creation
- ad. Desktop Instruction ED-CAD-DI-029 Modeling of Composites
- ae. Desktop Instruction ED-CAD-DI-030 Gathering Released Data in ICE Windchill
- af. Desktop Instruction ED-CAD-DI-031 Ground Strap Creation
- ag. Desktop Instruction ED-CAD-DI-032 Folder Structure
- ah. Desktop Instruction ED-CAD-DI-033 Create, Revise, Modify, and Promote
- ai. Desktop Instruction ED-CAD-DI-034 Modular Product Architecture
- aj. Desktop Instruction ED-CAD-DI-035 Computer-Aided Design (CAD) Management Prior to Release
- ak. Desktop Instruction ED-CAD-DI-036 Preparation and Processing of an ICE Windchill Change Request for CAD and WT Part Release

### **3. ACRONYMS/DEFINITIONS**

#### **3.1 Acronyms**

2D	2-Dimensional
3D	3-Dimensional
BOM	Bill of Materials
CAD	Computer-Aided Design
CDR	Critical Design Review
CM	Configuration Management
CR	Change Request
DI	Desktop Instruction
EPL	Engineering Parts List
GDRM	Global Drawing Requirements Manual
GD&T	Geometric Dimensioning and Tolerancing
GSE	Ground Support Equipment
ICD	Interface Control Document or Interface Control Drawing
ICE	Integrated Collaborative Environment
IES	Integrated Engineering System

**CHECK THE MASTER LIST  
VERIFY THAT THIS IS THE CORRECT VERSION BEFORE USE**

<b>MSFC Technical Standard EV32</b>		
<b>Title: Computer-Aided Design (CAD) Standard</b>	<b>Document No.: MSFC-STD-3528</b>	<b>Revision: Revision E</b>
	<b>Effective Date: 10-JAN-2017</b>	<b>Page 15 of 98</b>

- Lbm     Pounds Mass
- MBD    Model Based Definition
- mmKS   millimeter Kilogram Second
- MPA    Modular Product Architecture
- MSFC   Marshall Space Flight Center
- OML    Outer Mold Line
- PDR    Preliminary Design Review
- PLM    Product Lifecycle Management
- RMB    Right Mouse Button
- STE    Special Test Equipment
- UDF    User Defined Feature
- WGA    Workgroup Approval

3.2        Definitions

- Backward Inheritance     A method of creating -MOD and -MFG files. All features necessary to show all manufacturing or mod states are created in one part. This part is inherited into a new part and features inside the inheritance are erased to show that particular manufacturing state.
- Baseline                    See ICE Windchill Baseline.
- Bill of Material (BOM)    A listing of all parts for an assembly. Also called EPL.
- Bulk Item                    Any item with a quantity of “As Required” on the EPL.
- Bottom-Up Design  
Methodology                Design of individual components independent of external references or controls.
- CAD Document             A version controlled object on ICE Windchill that can contain one primary CAD file, as well as other secondary reference files.
- CAD File                    A file used within the Creo Parametric design software which includes CAD parts, assemblies, drawings, formats, sketches, layouts, etc. (.prt, .asm, .drw, etc.)
- CAD Model Structure     The relationships between models and where those models are used or referenced.
- CAD Object                 See CAD Document.

**CHECK THE MASTER LIST  
VERIFY THAT THIS IS THE CORRECT VERSION BEFORE USE**

<b>MSFC Technical Standard EV32</b>		
<b>Title: Computer-Aided Design (CAD) Standard</b>	<b>Document No.: MSFC-STD-3528</b>	<b>Revision: Revision E</b>
	<b>Effective Date: 10-JAN-2017</b>	<b>Page 16 of 98</b>

Common Parts	Those items listed on the Common Parts List; can be standard parts and vendor parts.
Configuration Item	An aggregate of hardware, firmware, software, or any of its discrete portions, which satisfies an end-use function and is designated for CM. Configuration Items may vary widely in complexity, size, and type. The following are typically designated as Configuration Items: Top assemblies, main assemblies, components with specifications, spares units, and orbital/logistics replacement units.
Design Layout Drawing	Type of drawing created to define the overall configuration of a design; serves as an engineering work sheet from which engineering drawings are made; is not used for fabrication, procurement or inspection.
Effectivity	Defines the usage of a specific as-designed configuration for an event or range of events (flight(s), mission(s), test(s), etc.) by use of alpha-numeric values. It is NOT equivalent to as-built serial numbers, lot numbers, or calendar dates. Effectivity for subordinate components of an assembly must be equal to or greater than each applicable assembly effectivity where the component is used.
End Item	A type of WT Part that represents a Configuration Item. Effectivity can be designated against End Item WT Parts in ICE Windchill.
Forward Inheritance	A method of creating -MOD and -MFG files. Enough features are created in a part to show the first manufacturing state. This part is inherited into a new part and new features are created to show the next state. This is continued as many times as necessary to get a finished product.
ICE Windchill Baseline	A list of a particular collection of models at a certain point in time within ICE Windchill. This does not mean under configuration control. Referred as Managed Baseline within ICE Windchill.
Inseparable Assembly	An assembly whose piece parts cannot be separated and still retain their original form.
Lateral Dependency	Creating a direct dependency between components in an assembly without using a skeleton.
Lateral Inheritance	Creating an inheritance feature between unrelated parts.
Modular Product Architecture	A type of Top-Down Design Methodology which focuses on the explicit identification and control of the physical/mechanical interfaces

**CHECK THE MASTER LIST  
VERIFY THAT THIS IS THE CORRECT VERSION BEFORE USE**



<b>MSFC Technical Standard EV32</b>		
<b>Title: Computer-Aided Design (CAD) Standard</b>	<b>Document No.: MSFC-STD-3528</b>	<b>Revision: Revision E</b>
	<b>Effective Date: 10-JAN-2017</b>	<b>Page 17 of 98</b>

and/or their location in the design through the use of skeletons, but does not control the overall geometry of the design.

Mono-detail Drawing Part	Drawing of only one part or assembly. 1) A physical representation of a component or assembly as defined in the EPL or Bill of Material. 2) A Creo Parametric design software model file with a .prt extension
Creo Parametric Layout	Type of file used to create and modify models based on parameters and/or relations. Serves as a vital communication tool that controls all corresponding geometry in one central location, pictorially reflecting what each parameter drives and how.
Promotion Notice	Also called a Promotion Request. Enables the designer to set the state of one or more items to a new lifecycle state with a selection of review processes; allows the designer to promote objects to a WGA state using the WGA process.
Release	Configuration control of a file.
Reps	Short term for simplified representations.
Standard Parts	Those items governed by a national (e.g., National Aerospace Standard) or international (e.g., SAE Aerospace) standard; a non-vendor item part.
Top-Down Design Methodology	Method of placing critical information in a high-level location and communicating that information to the lower levels of the product structure.
WT Part	A version controlled object in ICE Windchill that contains attributes (e.g., number, name, CAGE Code, material, mass) and usage attributes (e.g. quantity, find numbers) for a part item (e.g., detail part, assembly, bulk item, skeleton, schematic) that will be released and/or utilized on the EPL/Bill of Materials/Product Structure. Item definition data (e.g., CAD models, drawings, EPLs, documents) are related to the WT Part to capture the complete design definition of the item. Relationships (i.e., component, assembly, next higher assembly) are created between WT Parts to create the Product Structure/Indented Parts List.

**CHECK THE MASTER LIST  
VERIFY THAT THIS IS THE CORRECT VERSION BEFORE USE**

<b>MSFC Technical Standard EV32</b>		
<b>Title: Computer-Aided Design (CAD) Standard</b>	<b>Document No.: MSFC-STD-3528</b>	<b>Revision: Revision E</b>
	<b>Effective Date: 10-JAN-2017</b>	<b>Page 18 of 98</b>

## **4. GENERAL REQUIREMENTS**

### **4.1 Default Settings**

#### **4.1.1 Start Part**

4.1.1.1 English and metric start part files **shall** be used in the creation of all parts.

4.1.1.2 If English parts are to be modeled, the English start part file **shall** be used.

4.1.1.3 Use of metric hardware should be avoided where possible.

4.1.1.4 If metric parts are to be modeled, the metric start part file **shall** be used.

4.1.1.5 These start parts are located on a controlled server and maintained by the Integrated Engineering System, (IES). The files are as follows:

a. Msfc-startpart\_std - This default start part **shall** be used on all English units designs. This part contains standard views, parameters, relations, datum planes, layers, simplified representations, and a coordinate system.

b. Msfc\_startprt\_metric - This default start part **shall** be used on all metric designs. This part contains all standard views, parameters, relations, datum planes, and a coordinate system.

#### **4.1.2 Start Assembly**

4.1.2.1 English and metric start assembly files **shall** be used in the creation of all assemblies.

4.1.2.2 If English assemblies are to be modeled, the English start assembly file **shall** be used.

4.1.2.3 If metric assemblies are to be modeled, the metric start assembly file **shall** be used.

4.1.2.4 These start assemblies are located on a controlled server and maintained by IES. The files are as follows:

a. Msfc-startassy\_std - This default start assembly **shall** be used on all English units. This assembly contains all standard views, parameters, relations, datum planes, and a coordinate system.

b. Msfc\_startasy\_metric - This is the default start assembly to be used on all metric designs. This assembly contains all standard views, parameters, relations, datum planes, and a coordinate system.

<b>MSFC Technical Standard EV32</b>		
<b>Title: Computer-Aided Design (CAD) Standard</b>	<b>Document No.: MSFC-STD-3528</b>	<b>Revision: Revision E</b>
	<b>Effective Date: 10-JAN-2017</b>	<b>Page 19 of 98</b>

#### 4.1.3 Start Drawing/Drawing Template

4.1.3.1 Drawing templates **shall** be utilized to assist users in quickly beginning a drawing.

4.1.3.2 The start parts, start assemblies, and drawing templates have parameters that **shall** control various fields in the title block.

4.1.3.3 These fields **shall** NOT be overridden by text such that the parameter is no longer controlling them.

4.1.3.4 The following drawing templates **shall** be used:

- a. MSFC\_DWG\_B\_TEMPLATE\_REV\*.DRW
- b. MSFC\_DWG\_C\_TEMPLATE\_REV \*. DRW
- c. MSFC\_DWG\_D\_TEMPLATE\_REV \*. DRW
- d. MSFC\_DWG\_E\_TEMPLATE\_REV \*. DRW
- e. MSFC\_DWG\_J\_TEMPLATE\_REV \*. DRW

where the “\*” will be replaced with the latest revision, such as -, A, B, etc.

#### 4.1.4 Dimensional and Angular Tolerances

4.1.4.1 All MSFC English start parts and assemblies **shall** have the following default tolerance values:

- a. Linear X.X            +/- 0.1
- b. Linear X.XX        +/- .03
- c. Linear X.XXX      +/- .010
- d. Angular X.X        +/- 0.5

These values control the default tolerance for all dimensional values whose tolerance is not otherwise explicitly displayed on the drawing.

4.1.4.2 Limit tolerancing **shall** NOT be used.

4.1.4.3 All tolerances **shall** be equal-bilateral, and all parts **shall** be modeled at the geometric mean of the tolerance band, except for drilled/reamed holes which may be modeled using the Recommended Holes Sizes in Appendix F and use positive unilateral tolerances.

**CHECK THE MASTER LIST  
VERIFY THAT THIS IS THE CORRECT VERSION BEFORE USE**

<b>MSFC Technical Standard</b>		
<b>EV32</b>		
<b>Title: Computer-Aided Design (CAD) Standard</b>	<b>Document No.: MSFC-STD-3528</b>	<b>Revision: Revision E</b>
	<b>Effective Date: 10-JAN-2017</b>	<b>Page 20 of 98</b>

4.1.4.4 If a specific dimension needs to have a tolerance other than the default values in Paragraph 4.1.4.1, the dimension **shall** be displayed using only the equal-bilateral tolerance format and the tolerance values adjusted as needed for that dimension on the face of the drawing.

4.1.4.5 If the entire drawing requires tolerances other than tolerances in the drawing format title block, the new tolerances **shall** be defined by a general note which will over-ride the format title block tolerances.

4.1.4.6 The drawing title block fields for default tolerances **shall NOT** be manually overridden.

#### 4.1.5 Systems of Units

4.1.5.1 The units of the start parts/assemblies are as follows:

a. Inch Lbm (Pounds Mass) Second for Msfc\_startpart\_std and Msfc\_startassy\_std. This is the Creo Parametric default.

b. Millimeter Kilogram Second (mmKS) for Msfc\_startprt\_metric and Msfc\_startassy\_metric.

#### 4.1.6 Part Accuracy

4.1.6.1 MSFC default start parts **shall** use an absolute accuracy of 0.0005 inches for English start parts and 0.0127 millimeters for metric start parts. The default value may be increased if geometry errors are produced with this value. After changing the accuracy, the model must be regenerated.

4.1.6.2 Relative accuracy **shall NOT** be used.

4.1.6.3 See Appendix B for additional information.

#### 4.2 Model and Drawing Integrity

4.2.1 ModelCHECK™ is an integrated application that runs transparently within Creo Parametric. ModelCHECK uses a configurable list of design standards and best modeling practices. It can be configured to run interactively as well as automatically when the designer regenerates or saves a model.

4.2.2 All designers **shall** run ModelCHECK interactively at the following points, at a minimum:

a. Prior to submittal for Preliminary Design Review (PDR) and Critical Design Review (CDR)

**CHECK THE MASTER LIST  
VERIFY THAT THIS IS THE CORRECT VERSION BEFORE USE**

<b>MSFC Technical Standard EV32</b>		
<b>Title: Computer-Aided Design (CAD) Standard</b>	<b>Document No.: MSFC-STD-3528</b>	<b>Revision: Revision E</b>
	<b>Effective Date: 10-JAN-2017</b>	<b>Page 21 of 98</b>

b. Prior to submittal for Configuration Management (CM) Release

4.2.3 All designers should run ModelCHECK interactively at the following points, at a minimum:

- a. At regular intervals throughout the design activity
- b. After creating Primary, Secondary, and Tertiary features for parts. Refer to Section 12 for additional information
- c. At initial check in for external or vendor parts
- d. Prior to submittal for Workgroup Approval (WGA)

4.2.4 Errors found by ModelCHECK **shall** be resolved prior to check in to ICE Windchill when changing state to design, for creation of a baseline, for WGA, at release, and other times as required at a minimum. Refer to Desktop Instruction ED-CAD-DI-026, Verifying 3-Dimensional CAD Models, for acceptable occurrences of modeling techniques that ModelCHECK lists as an error.

Warnings **shall** be evaluated and resolved where possible. Refer to Desktop Instruction ED-CAD-DI-026, Verifying 3-Dimensional CAD Models, for information on running ModelCHECK and resolving resulting errors and warnings.

4.2.5 See Appendix B for additional information.

#### 4.3 General Drafting Requirements

4.3.1 Drawings **shall** be prepared in accordance MSFC-STD-2806 and the Global Drawing Requirements Manual (GDRM) 10<sup>th</sup> Edition. The GDRM contains requirements from ASME Y14.100 and its subtier documents, including ASME Y14.5M-1994. ASME Y14.41-2003 is also applicable for controlling digital data sets.

4.3.2 The EPLs **shall** be generated within ICE Windchill and be separate from the drawing for MSFC released drawings. (Refer to Paragraph 8.11)

4.3.3 When preparing a drawing utilizing Creo Parametric design software, the following requirements apply:

4.3.3.1 All views and dimensions **shall** be derived from the model, except as allowed in Paragraph 14.3.11.

4.3.3.2 Sketching in of model geometry and overriding of dimensions **shall NOT** be allowed.

<b>MSFC Technical Standard EV32</b>		
<b>Title: Computer-Aided Design (CAD) Standard</b>	<b>Document No.: MSFC-STD-3528</b>	<b>Revision: Revision E</b>
	<b>Effective Date: 10-JAN-2017</b>	<b>Page 22 of 98</b>

4.3.3.3 Notes on drawings **shall** come from the Standard Notes List (Refer to Paragraph 7.2) when an appropriate note is available. Other notes not covered in the standard notes list may be added to the drawing as required.

4.3.4 Detailed Drawing Guidelines are given in Section 14.

## **5. NAMING CONVENTION**

### **5.1 Initial CAD Identification**

#### **5.1.1 Initial Creo Parametric CAD Name, Common Name, and File Name**

5.1.1.1 The naming requirements in Table 1 **shall** be used when creating a Creo Parametric object prior to official MSFC numbers being assigned. Figure 1 shows the Creo Parametric interface where the identification is entered. If MSFC numbers have already been assigned, the MSFC numbers may be used in accordance with Paragraph 5.3.1.

<b>TABLE 1. Creo Parametric CAD Initial Naming Requirements</b>	
<b>Creo Parametric Field Name</b>	<b>3D CAD Model or 2D CAD Drawing</b>
Name (File Name) (User entered)	Utilize Project CAD Naming Convention described in Section 5 of this standard. NOTE: A file extension .prt, .asm, or .drw is automatically added to the Name field value to create the file name based on the type of file selected.
Common Name (User entered)	Assign name using all CAPS in a format specified by the drawing title requirements of GDRM Sec 8.0 Procedures or ASME Y 14.100 Section 5.0/Appendix C. (See Para. 6.5.3)
File Name (System generated)	Software completes the file name from the Creo Parametric Name field by adding the file extension .prt, .asm, or .drw

**CHECK THE MASTER LIST  
VERIFY THAT THIS IS THE CORRECT VERSION BEFORE USE**

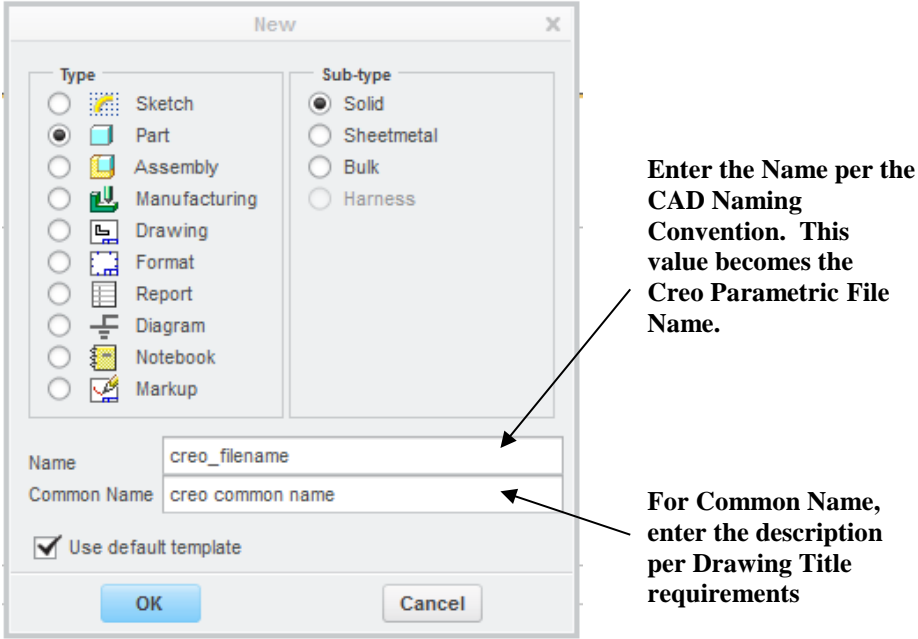

**Figure 1. Creo Parametric Name Entry Interface**

5.1.2 Initial ICE Windchill CAD Number, Name, and File Name

5.1.2.1 The naming requirements in Table 2 **shall** be used when creating an ICE Windchill CAD Document prior to official MSFC numbers being assigned. Figure 2 shows how the Creo Parametric naming maps to the ICE Windchill CAD model fields. If MSFC numbers have already been assigned, the MSFC numbers may be used in accordance with Paragraph 5.3.1.

<b>TABLE 2. ICE Windchill CAD Initial Numbering/Naming Requirements</b>	
<b>ICE Windchill Field Name</b>	<b>3D CAD Model or 2D CAD Drawing</b>
Number	Utilize Project CAD Numbering Convention described in Section 5 of this standard. (NOTE: When Creo Parametric is uploaded to ICE Windchill, this value is automatically mapped from the Creo Parametric Name (File Name) field including the file extension .prt, .asm, or drw.)
Name	Assign name using all CAPS in a format specified by the GDRM Sec 8.0 Procedures or ASME Y 14.100 Section 5.0/Appendix C (NOTE: When Creo Parametric is uploaded to ICE Windchill, this field value is automatically mapped from the Creo Parametric Common Name field)
File Name	Utilize Project CAD Numbering Convention described in Section 5. (NOTE: When Creo Parametric is saved to ICE Windchill workspace, this field value displays the Creo Parametric Name (File Name) field with file extension .prt, .asm, or drw)

**CHECK THE MASTER LIST  
VERIFY THAT THIS IS THE CORRECT VERSION BEFORE USE**

MSFC Technical Standard EV32		
<b>Title: Computer-Aided Design (CAD) Standard</b>	<b>Document No.: MSFC-STD-3528</b>	<b>Revision: Revision E</b>
	<b>Effective Date: 10-JAN-2017</b>	<b>Page 24 of 98</b>

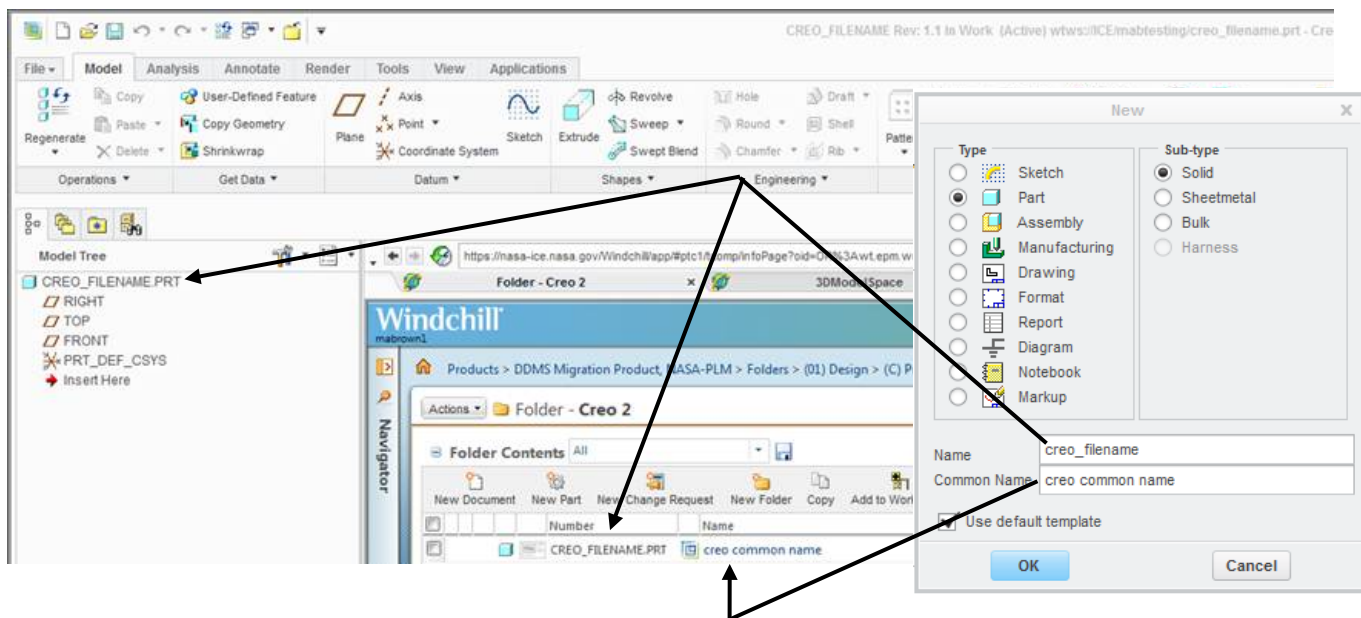

**Figure 2. ICE Windchill Name Entry Interface**

## 5.2 Initial CAD File Name

5.2.1 If MSFC numbers have already been assigned, the MSFC numbers may be used in accordance with Paragraph 5.3.1. Otherwise, the initial CAD file name should be a logical name that is descriptive of the file. Because 31 characters are the most that are allowed within Creo Parametric, the file name **shall** be limited to 25 characters initially to provides flexibility for adding extensions as needed during trades.

5.2.2 See Appendix A for an example of project specific initial CAD file naming details and examples.

## 5.3 Final CAD Identification for “As-Designed” Model

### 5.3.1 Final ICE Windchill and Creo Parametric CAD Identification

5.3.1.1 The numbering and naming convention in Table 3 **shall** be assigned to ICE Windchill Objects prior to release. It is recommended that this naming convention is utilized as soon as official MSFC numbers have been assigned:

**CHECK THE MASTER LIST  
VERIFY THAT THIS IS THE CORRECT VERSION BEFORE USE**



<b>MSFC Technical Standard EV32</b>		
<b>Title: Computer-Aided Design (CAD) Standard</b>	<b>Document No.: MSFC-STD-3528</b>	<b>Revision: Revision E</b>
	<b>Effective Date: 10-JAN-2017</b>	<b>Page 25 of 98</b>

<b>TABLE 3. ICE Windchill CAD Final Numbering/Naming Requirements</b>		
<b>ICE Windchill Field Name</b>	<b>3D CAD Model</b>	<b>2D CAD Drawing</b>
File Name	Part number plus file extension assigned by CAD package (e.g., .prt or .asm for Creo Parametric files)	a. The shown part number for drawings with a shown and opposite configuration; or  b. The base drawing number with no dash number for other drawings such as tabulated or non-part drawings (e.g., schematics) or  c. The same as the part number for all other drawings.
Number	Same as File Name.	Same as File Name.
Name	Assign name from Drawing Title requirements in the GDRM Sec 8.0 Procedures or ASME Y 14.100 Section 5.0/Appendix C. (See Para. 6.5.3)	Assign name from Drawing Title requirements in the GDRM Sec 8.0 Procedures or ASME Y 14.100 Section 5.0/Appendix C

- 5.3.1.2 Final base drawing numbers **shall** be obtained from the MSFC Release Desk.
- 5.3.1.3 The dash number **shall** be assigned by the project or design organization.
- 5.3.1.4 Dash Numbers for part and assembly files **shall** be -001, -003, etc., or -002, -004, etc. for opposites, or -101, -103, etc. for parts/assemblies defined as an inseparable assembly in Section 13.14.1 and not detailed on their own drawing.
- 5.3.1.5 Drawing numbers **shall** NOT be re-used. If a drawing number is assigned and a change deletes that part, then that drawing number is discarded and not ever used.
- 5.3.1.6 Files **shall** be renamed from the initial CAD file name to the final CAD file name as follows, whichever comes first:
- a. Rename files when ready for formal approval cycle
    - (1) This keeps the file name meaningful to those not working that subsystem
    - (2) This would help keep from wasting drawing numbers
    - (3) This would be most applicable to assembly files and associated drawings that would be released later than part files

**CHECK THE MASTER LIST  
VERIFY THAT THIS IS THE CORRECT VERSION BEFORE USE**

<b>MSFC Technical Standard EV32</b>		
<b>Title: Computer-Aided Design (CAD) Standard</b>	<b>Document No.: MSFC-STD-3528</b>	<b>Revision: Revision E</b>
	<b>Effective Date: 10-JAN-2017</b>	<b>Page 26 of 98</b>

b. Rename files when ready for design review deliverable

(1) This allows the manufacturing organization to track the files and get their system in place using the number for which they will ultimately deliver hardware

(2) This would be most applicable to parts, especially long lead items

(3) The drawing number assignment spreadsheet **shall** be available so that those not working that subsystem would know who owned any given file at least down to the subsystem level

5.3.1.7 Parts and related objects **shall** only be renamed in ICE Windchill. ICE Windchill tracks all file relationships, and objects renamed outside of ICE Windchill will lose all references to objects within ICE Windchill. Refer to Desktop Instruction ED-CAD-DI-002, Naming and Renaming Files in ICE Windchill, for additional information. See Appendix B for additional information on how to sort by part number within ICE Windchill.

#### 5.4 Companion CAD File Identification

5.4.1 Companion CAD Files are CAD models created in order to manage CAD data (i.e. Shrinkwrap™ files, skeletons, envelopes, related assemblies, etc.) or provide additional part information (modified models, manufacturing models, Stress and Analysis models, etc.). These companion models **shall** have the same part number as the primary model plus a type extension.

5.4.2 File extensions **shall** be used to differentiate between the “As-Designed” CAD model which uses the base part number and other types of companion CAD models. (Refer to Paragraph 8.8.2.3 for additional information on companion models.)

5.4.3 The following extensions **shall** be added after the dash number for the part or assembly when applicable:

<b>TABLE 4. Companion File Extensions</b>	
<b><u>EXTENSION</u></b>	<b><u>DESCRIPTION</u></b>
-ACM1, -ACM2, etc.	Alignment Control Model containing nominal locations, components, datums, etc.
-ALT1, -ALT2, etc.	Model created to provide an alternate representation of the primary CAD model such as simplified substitutes
-BULK1, BULK2, etc.	Any modeled bulk items, such as Spray on Pipe Insulation and Propellant (See Section 6.8)
-DEP1, -DEP2, etc.	Deployed models
-DYN1, -DYN2, etc.	Dynamics models
-ENV1, -ENV2, etc.	1) Envelope part models, accurately representing the Outer Mold Line (OML) of the part/assembly as a single part

**CHECK THE MASTER LIST  
VERIFY THAT THIS IS THE CORRECT VERSION BEFORE USE**

<b>MSFC Technical Standard EV32</b>		
<b>Title: Computer-Aided Design (CAD) Standard</b>	<b>Document No.: MSFC-STD-3528</b>	<b>Revision: Revision E</b>
	<b>Effective Date: 10-JAN-2017</b>	<b>Page 27 of 98</b>

<b>TABLE 4. Companion File Extensions</b>	
<b><u>EXTENSION</u></b>	<b><u>DESCRIPTION</u></b>
	2) Envelope models for Envelope, Source Control Drawings, Vendor Item Control Drawings
-FLAT1, -FLAT2, etc.	Flat state of sheet metal parts or flat pattern for cables
-GEN1, -GEN2, etc.	Generic of family table part instance. The generic should be associated to all WT Parts whose master defining model is a family table instance.
-HRN1, -HRN2, etc.	Harness subassembly models
-ICD1, -ICD2, etc.	Interface Control Document (ICD) skeleton models
-ICM1, -ICM2, etc.	Interface Control Model containing nominal interface locations, interface details, etc.
-IDP1, -IDP2, etc.	Interface Detail Product. Model containing a subset of models necessary to define a mechanical interface.
-LAY1, -LAY2, etc.	Design Layout drawing models (not Creo Parametric Layouts)
-MASS1, -MASS2, etc.	Mass properties models
-MVA1, -MVA2, etc.	Model View Assembly which facilitates copying geometry from simplified reps
-MFG1, -MFG2, etc.	Models created to support manufacturing (typically captures intermediate manufacturing states of the part).
-MOD1, -MOD2, etc.	Modified representation of the part design such as an “As-Installed” model.
-NOTE1, -NOTE2, etc.	Notebooks
-PATL1, -PATL2, etc.	Partial assemblies used in large file management
-PIPE1, -PIPE2, etc.	Pipe subassembly models
-PKG1, -PKG2, etc.	Package subassembly models
-REL1, -REL2, etc.	Related model assembly used for creation of drawings for large assemblies, used for installation/integration/design layout drawings.
-SIM1, -SIM2, etc.	Model created to support an analysis or simulation
-SKL1, -SKL2, etc.	Skeleton models (not ICDs)
-SWR1, -SWR2, etc.	Shrinkwrap models
-TRD1, -TRD2, etc.	Trade Study models

## 5.5 CAD File Name for Vendor Parts

5.5.1 The CAD file name for vendor parts **shall** match the vendor part number. The vendor file name **shall** NOT exceed 25 characters and **shall** be followed by an underbar (\_) and the MSFC 2-character identifier of MS; for example NAS1351N3-6\_MS. Refer to NASA-STD-(I)-0007 for additional information.

**CHECK THE MASTER LIST  
VERIFY THAT THIS IS THE CORRECT VERSION BEFORE USE**

<b>MSFC Technical Standard EV32</b>		
<b>Title: Computer-Aided Design (CAD) Standard</b>	<b>Document No.: MSFC-STD-3528</b>	<b>Revision: Revision E</b>
	<b>Effective Date: 10-JAN-2017</b>	<b>Page 28 of 98</b>

5.5.2 When vendor part numbers include characters that are not allowed, such as a slash (/), an underbar (\_) **shall** be substituted for such characters.

5.5.3 The relation PART\_NUMBER=REL\_MODEL\_NAME must be deleted for vendor parts. The exact part number **shall** then be entered using the Part\_Number parameter without the \_MS identifier.

5.6 Numbering and Naming of ICE Windchill Baseline and ICE Windchill Change Requests (CRs) for WGA and Other Release

5.6.1 ICE Windchill Baseline Numbering and Naming

5.6.1.1 ICE Windchill Baseline Number

ICE Windchill Baselines are either auto-numbered by the ICE Windchill system, or the ICE Windchill Baseline number should be assigned in accordance with the ICE Windchill Baseline Name requirements in Paragraph 5.6.1.2 such that the baseline Number and Name field match.

5.6.1.2 ICE Windchill Baseline Name

ICE Windchill Baselines should be named using the following convention:

(1)\_(2)\_(3)\_(4)

The values for each item are defined below.

(1) Milestone/Reason for Baseline (e.g., DAC, PDR Start, PDR End, PDR Subsystem Start, PDR Subsystem End, WGA, CR Number)

(2) Highest Assembly Part Number (e.g., 97MXXXXX-001), or CR Title

(3) Name/Abbreviation of Assembly or Drawing including where used (e.g., Project Element Subsystem Part/Drawing - ARES US Common Bulkhead Y-Ring Forging)

(4) User defined (Optional)

Example 1: PDR Subsystem Start\_97MXXXXX-001\_ARES US Common Bulkhead

Example 2: PDR System Start\_97MXXXXX-001\_ARES US Common Bulkhead

Example 3: WGA PDR System Start\_97MXXXXX-001\_ARES US Common Bulkhead

Example 4: CR CLV-US-0026\_97M12345-001\_ARES US Common Bulkhead Y-Ring Forging

5.6.2 ICE Windchill CR Numbering and Naming for WGA

The type of CR for WGA **shall** be NASA WGA Change Request.

**CHECK THE MASTER LIST  
VERIFY THAT THIS IS THE CORRECT VERSION BEFORE USE**

<b>MSFC Technical Standard EV32</b>		
<b>Title: Computer-Aided Design (CAD) Standard</b>	<b>Document No.: MSFC-STD-3528</b>	<b>Revision: Revision E</b>
	<b>Effective Date: 10-JAN-2017</b>	<b>Page 29 of 98</b>

#### 5.6.2.1 CR Number for WGA

Each CR number **shall** be a unique number.

#### 5.6.2.2 WGA CR Naming

WGA CRs should be named using the following convention. This convention is identical to the Baseline Naming Convention for a WGA.

(1)\_(2)\_(3)\_(4)

The values for each item are defined below.

(1) “WGA” plus Milestone/Reason for WGA

(2) Highest Assembly Part Number (e.g., 97MXXXXXX-001)

(3) Name/Abbreviation of Assembly or Drawing including where used (e.g., Project Element Subsystem Part/Drawing - ARES US Common Bulkhead Y-Ring Forging)

(4) User defined (Optional)

Example 1: WGA\_PDR\_System\_Start\_97MXXXXXX-001\_ARES US Common Bulkhead

Example 2: WGA\_97MXXXXXX-001\_ARES US Common Bulkhead\_2008-05-30

#### 5.6.3 ICE Windchill CR Numbering and Naming for Release

The type of CR for release **shall** be NASA Change Request.

##### 5.6.3.1 CR Number for Release

a. Each CR number **shall** be a unique number.

b. CR numbers **shall** be assigned either by the originating organization from the organization’s CR log, or assigned by the receiving Project from the Project’s CR log.

(1) MSFC organizations **shall** assign CR numbers in the following format:

Org Code-XXXX, where XXXX equals a sequential number starting with 0001

(2) Projects may assign CR numbers per the numbering system established in the Project’s CM Plan.

<b>MSFC Technical Standard EV32</b>		
<b>Title: Computer-Aided Design (CAD) Standard</b>	<b>Document No.: MSFC-STD-3528</b>	<b>Revision: Revision E</b>
	<b>Effective Date: 10-JAN-2017</b>	<b>Page 30 of 98</b>

### 5.6.3.2 CR Name (or Title)

CRs should be named using the following convention. This convention is identical to the Baseline Naming Convention for a CR.

(1)\_(2)\_(3)\_(4)

The values for each item are defined below.

(1) Highest Assembly Part Number in the CR Promotion Notice (e.g., 97MXXXXXX-001)

(2) Name/Abbreviation of Assembly or Drawing including where used (e.g., Project Element Subsystem Part/Drawing - ARES US Common Bulkhead Y-Ring Forging), or Description of the reason for the CR (e.g., Initial Release)

(3) User defined (Optional)

Example 1: CR 97MXXXXXX-001\_ARES US Common Bulkhead Y-Ring Forging

Example 2: CR 97MXXXXXX-001\_ARES US Common Bulkhead Y-Ring Forging Initial Release

## 5.7 WT Part Identification

5.7.1 Prior to release, WT Parts **shall** be identified in accordance with Table 4.

<b>TABLE 5. ICE Windchill WT Part Identification Requirements</b>	
<b>ICE Windchill Field Name</b>	<b>WT Part</b>
Number	Part number (9XMXXXXXX-XXX)
Name	Assign name using the Drawing Title requirements in the GDRM Sec 8.0 procedures or ASME Y 14.100 Section 5.0/Appendix C

## 6. **STANDARD PRACTICES**

### 6.1 Layers

#### 6.1.1 Layer Usage

6.1.1.1 All non-solid items **shall** be placed on a layer.

6.1.1.2 Items **shall** reside on one layer only.

**CHECK THE MASTER LIST  
VERIFY THAT THIS IS THE CORRECT VERSION BEFORE USE**

MSFC Technical Standard EV32		
Title: Computer-Aided Design (CAD) Standard	Document No.: MSFC-STD-3528	Revision: Revision E
	Effective Date: 10-JAN-2017	Page 31 of 98

6.1.1.3 Visibility of items **shall** NOT be controlled by UNHIDE or HIDE in the model tree at check in. Layers are used to control visibility of items, while UNHIDE or HIDE is for temporary use only.

6.1.1.4 All layers of a drawing **shall** be hidden, unless a layer is necessary to properly represent the drawing intent, and all layers **shall** have their status saved such that the appearance of the drawing is retained.

6.1.1.5 All drawings **shall** be controlled by layers at the drawing level, not at the model level.

6.1.1.6 All non-solid layers **shall** be set to hidden when checked into ICE Windchill except for drawings.

6.1.1.7 See Appendix B for additional information.

#### 6.1.2 Default Layers

6.1.2.1 All MSFC start files **shall** have default layers set up with rules or as controlled by the config.pro and the default layer model.

6.1.2.2 The following **shall** be utilized as the default layers within all MSFC CAD part models and assemblies and **shall** NOT be renamed:

01_PLANES	(Created Planes)
01_DEF_PLANES	(Default Planes)
02_CSYS	(Created CSYS)
02_DEF_CSYS	(Default CSYS)
03_AXES	(All Axes)
04_POINTS	(All Points)
05_CURVES	(All Curves)
06_GTOLS	(Geometric Tolerances)
07_SURFACES	(All Surfaces)
08_EXT_GEOM	(Any Copy or External Geometry)
09_COSMETICS	(All Cosmetic Features except Threads)
10_COSMETIC_THREADS	(Cosmetic Threads Only)
11_IMPORTED_GEOM	(Imported Geometry and Neutral Files)
12_PIPELINES	(All Piping features)
13_MODEL_NOTES	(Model Notes, Hole Callouts, other Annotations)

The following **shall** be utilized as the default layers within all MSFC drawings and **shall** NOT be renamed:

01_DRW_DRAFT_GTOL_DTMS	(All Drawing Geometric Tolerance Draft Datums)
------------------------	--

**CHECK THE MASTER LIST  
VERIFY THAT THIS IS THE CORRECT VERSION BEFORE USE**

MSFC Technical Standard EV32		
Title: Computer-Aided Design (CAD) Standard	Document No.: MSFC-STD-3528	Revision: Revision E
	Effective Date: 10-JAN-2017	Page 32 of 98

6.1.2.3 Models or drawings without standard layer assignments **shall** have the above layers assigned using the standard MSFC scripts. Refer to ED-CAD-DI-017, Creating Standard Layers, for additional information on setting up layers within models and drawings.

6.1.2.4 Addition of layers should be kept to a minimum.

6.1.2.5 Additional layers shall have a prefix of 99\_ followed by a user-defined description. (Example: 99\_CONSTRUCT\_DTMS)

## 6.2 Colors

6.2.1 Colors can be used to give a part or assembly model a certain look or texture that may be desirable to the designer. All MSFC models **shall** have default colors controlled by the config.pro, which points to the appearance.dmt file.

6.2.2 The following colors **shall** be used for the following types of routed lines as defined in the standard color table:

6.2.2.1 Hydrogen lines **shall** be RED.

6.2.2.2 Oxygen lines **shall** be GREEN.

6.2.2.3 Helium lines **shall** be YELLOW.

6.2.2.4 Nitrogen lines **shall** be BLUE.

6.2.2.5 Power cabling **shall** be GRAY.

6.2.2.6 Data cabling **shall** be BROWN.

6.2.2.7 Pyrotechnic lines **shall** be PURPLE.

6.2.3 Colors **shall** NOT be assigned at the assembly level for the above items.

6.2.4 Black or white **shall** NOT be used for any model.

## 6.3 Materials

6.3.1 Every homogeneous solid body **shall** have material assigned from the standard materials list. The standard materials list includes the appropriate density.

6.3.2 The selected material is automatically populated into the appropriate field in ICE Windchill. A standard materials library **shall** be maintained by IES.

6.3.3 Non-homogeneous or purchased items **shall** NOT have materials assigned.

**CHECK THE MASTER LIST  
VERIFY THAT THIS IS THE CORRECT VERSION BEFORE USE**



<b>MSFC Technical Standard EV32</b>		
<b>Title: Computer-Aided Design (CAD) Standard</b>	<b>Document No.: MSFC-STD-3528</b>	<b>Revision: Revision E</b>
	<b>Effective Date: 10-JAN-2017</b>	<b>Page 33 of 98</b>

6.3.4 Refer to Desktop Instruction ED-CAD-DI-019, Adding Materials and Generating Mass Properties.

#### 6.4 Mass Properties

6.4.1 Every part **shall** have Mass Properties.

6.4.2 When a component solid body is modeled with sufficient detail, mass properties **shall** be calculated by Creo Parametric and updated prior to WGA or other approval cycle and at intermediate points at the designer's discretion.

6.4.3 Otherwise, mass properties **shall** be manually entered using the alternate mass properties parameters.

6.4.4 The parameter Mass **shall** contain the correct value for the calculated mass of the part or the manually entered value for the part.

6.4.5 Refer to Desktop Instruction ED-CAD-DI-019, Adding Materials and Generating Mass Properties.

#### 6.5 Parameters

6.5.1 All user defined parameters controlling solid geometry **shall** have units assigned.

6.5.2 Dimensionless units (number of places, etc.) **shall** NOT have units assigned.

6.5.3 The Drawing Title **shall** match the Common Name field in ICE Windchill and Creo Parametric.

6.5.4 The designer **shall** correctly populate or verify the accuracy of the following standard parameters.

##### 6.5.4.1 Part/Assembly Parameters

<b>TABLE 6. Part/Assembly Parameters</b>		
<u>Parameter Name</u>	<u>Usage Information</u>	<u>Designer Responsibility</u>
DESCRIPTION	Contains the data entered in the model's Common Name field. Controlled through a relation to PTC_COMMON_NAME.	No action required by the Designer.
FRACTURE_CRITICAL	Identifies whether the model is fracture critical. Defaulted to "no".	Designer <b>shall</b> verify "no" is correct or change to "yes".
MATERIAL	(Part Parameter only) Contains the material description of the material selected for the model. Controlled through a relation to PTC_MATERIAL_DESCRIPTION.	Designer <b>shall</b> verify the information reflects the correct material. If no material description applies, delete the default

**CHECK THE MASTER LIST  
VERIFY THAT THIS IS THE CORRECT VERSION BEFORE USE**

<b>MSFC Technical Standard EV32</b>		
<b>Title: Computer-Aided Design (CAD) Standard</b>	<b>Document No.: MSFC-STD-3528</b>	<b>Revision: Revision E</b>
	<b>Effective Date: 10-JAN-2017</b>	<b>Page 34 of 98</b>

<b>TABLE 6. Part/Assembly Parameters</b>		
<u>Parameter Name</u>	<u>Usage Information</u>	<u>Designer Responsibility</u>
	Defaulted to “This material is a placeholder and should be replaced with a real material.”	statement from the model’s Material Definition.
METRIC UNITS	Identifies whether metric units are used in the model. Defaulted to “no” for the English Start Parts. Defaulted to “yes” for the Metric Start Parts.	Designer <b>shall</b> verify the correct entry is selected.
PART_NUMBER	Contains the number of the model. Controlled through a relation to REL_MODEL_NAME.	No action required by the Designer. For vendor parts, the designer may delete the relation and manually enter the part number when the part number contains special characters. See Section 5.5.
PART_TYPE	Identifies the part type: 1 = assemblies, 2 = detail parts, 3 = vendor components (valves, source control items, etc.), 4 = standard parts (fasteners, fittings, connectors, etc.).	Designer may enter the part type or leave blank (optional field).
ENGINEER	Identifies the name of the Engineer with primary responsibility for design captured in the model.	Designer <b>shall</b> enter the name of the responsible engineer. (FIRST NAME LAST NAME)
TRACE_CODE	Identifies the material traceability level number (i.e., 1, 2, 3, or 4) per MSFC-STD-555 that applies to the material selected for the model, when material traceability applies.	Designer <b>shall</b> assign the applicable material traceability level or leave blank.
CAGE_CODE	Identifies the CAGE Code for the part. Default value is the MSFC CAGE Code, 339B2. Used in the MSFC drawing format in the Title block, Code field.	Designer <b>shall</b> verify information is correct.
DENSITY	(Part Parameter only) Controlled through a relation to PRO_MP_DENSITY.	Designer <b>shall</b> verify the information is correct.
MASS	Contains the calculated Mass based on the selected material, density, and model dimensions. Controlled through a relation. Used in the MSFC drawing format in the Title block, Mass field.	Designer <b>shall</b> verify the information is correct. (i.e., regenerate, etc.)
PTC_MATERIAL_NAME	Contains the name of the material selected for this model. Controlled through a relation. Defaulted to “NO_MATERIAL”.	Designer <b>shall</b> verify the information is correct.

#### 6.5.4.2 Drawing Parameters

<b>TABLE 7. Drawing Parameters</b>		
<u>Parameter Name</u>	<u>Usage Information</u>	<u>Designer Responsibility</u>
DESIGN_ORG.	Identifies the organization code of the designer responsible for the drawing. Used in the MSFC	Designer <b>shall</b> enter his design organization (i.e., EV32)

**CHECK THE MASTER LIST  
VERIFY THAT THIS IS THE CORRECT VERSION BEFORE USE**

<b>MSFC Technical Standard EV32</b>		
<b>Title: Computer-Aided Design (CAD) Standard</b>	<b>Document No.: MSFC-STD-3528</b>	<b>Revision: Revision E</b>
	<b>Effective Date: 10-JAN-2017</b>	<b>Page 35 of 98</b>

<b>TABLE 7. Drawing Parameters</b>		
<u>Parameter Name</u>	<u>Usage Information</u>	<u>Designer Responsibility</u>
	drawing format in the Title block, Design Org field.	
DRAWN_BY	Identifies the name of the designer that prepared the drawing. Used in the MSFC drawing format in the Title block, Drawn By field.	Designer <b>shall</b> enter his name. (FIRST NAME LAST NAME)
TITLE1	Identifies the first line of the drawing title. Used in the MSFC drawing format in the Title block, Title field.	Designer <b>shall</b> enter up to first 20 characters of Name per Paragraph 5.3
TITLE2	Identifies the second line of the drawing title. Used in the MSFC drawing format in the Title block, Title field.	Designer <b>shall</b> enter up to second 20 characters of Name per Paragraph 5.3
TITLE3	Identifies the third line of the drawing title. Used in the MSFC drawing format in the Title block, Title field.	Designer <b>shall</b> enter up to third 20 characters of Name per Paragraph 5.3

The following drawing parameters are used to display information related to the release process.

<b>TABLE 8. Drawing Approval/Release Parameters</b>		
<u>Parameter Name</u>	<u>Usage Information</u>	<u>Designer Responsibility</u>
REVRELEASEDATE	Identifies the release date of the current drawing revision. Used in the MSFC drawing format Revisions block, REL DATE field.	Complete per applicable release instructions.
REVISIONAUTH NUMBER	Identifies the document number that authorized release of the current drawing revision. Used in the MSFC drawing format Revisions block, APPROVAL field.	Complete per applicable release instructions.
CHECKER	Identifies the Checker approval of the initial released revision. Used in the MSFC drawing format Title block, CHECKER field.	Complete per applicable release instructions.
MATERIALS	Identifies the Materials approval of the initial released revision. Used in the MSFC drawing format Title block, MATERIALS field.	Complete per applicable release instructions.
STRESS	Identifies the Stress approval of the initial released revision. Used in the MSFC drawing format Title block, STRESS field.	Complete per applicable release instructions.
SMA	Identifies the S&MA approval of the initial released revision. Used in the MSFC drawing format Title block, SMA field.	Complete per applicable release instructions.

**CHECK THE MASTER LIST  
VERIFY THAT THIS IS THE CORRECT VERSION BEFORE USE**

<b>MSFC Technical Standard EV32</b>		
<b>Title: Computer-Aided Design (CAD) Standard</b>	<b>Document No.: MSFC-STD-3528</b>	<b>Revision: Revision E</b>
	<b>Effective Date: 10-JAN-2017</b>	<b>Page 36 of 98</b>

**TABLE 8. Drawing Approval/Release Parameters**

<u>Parameter Name</u>	<u>Usage Information</u>	<u>Designer Responsibility</u>
MANUFAC	Identifies the Manufacturing approval of the initial released revision. Used in the MSFC drawing format Title block, MANUFACTURE field.	Complete per applicable release instructions.
CONTRACTOR	Leave blank.	Complete per applicable release instructions.
NEXTHIGHER	Identifies the Next Higher Assembly approval of the initial released revision. Used in the MSFC drawing format Title block, NHA AUTH field.	Complete per applicable release instructions.
DESIGNBRANCH	Identifies the Design Branch Chief approval of the initial released revision. Used in the MSFC drawing format Title block, BRANCH CHIEF field.	Complete per applicable release instructions.
RELEASEDATE	Identifies the Release Date of the initial released revision. Used in the MSFC drawing format Title block, RELEASE DATE field.	Complete per applicable release instructions.
INITIALAUTH NUMBER	Identifies the document number that authorized release of the initial released revision. Used in the MSFC drawing format Title block, AUTH NUMBER field.	Complete per applicable release instructions.
RELEASEFUNCTION	Identifies the Release Function responsible for the drawing release. Used in the MSFC drawing format Applications block, RELEASE FUNCT field.	Complete per applicable release instructions.

6.5.5 See Appendix B for additional information.

## 6.6 Relations

6.6.1 Relations are user-defined equations written between dimensions and parameters. Relations let the designer control relationships between features and/or parts.

6.6.2 All constant values used in relations **shall** have appropriate units assigned.

6.6.3 Sketcher relations **shall NOT** create references external to the sketch.

6.6.4 Relations **shall** be created at the part level unless limited by Creo Parametric design software.

6.6.5 Assembly level relations **shall NOT** be used to control geometry and features of parts.

6.6.6 Refer to Paragraph 12.6 for additional information on Part/Sketcher relations.

**CHECK THE MASTER LIST  
VERIFY THAT THIS IS THE CORRECT VERSION BEFORE USE**

<b>MSFC Technical Standard EV32</b>		
<b>Title: Computer-Aided Design (CAD) Standard</b>	<b>Document No.: MSFC-STD-3528</b>	<b>Revision: Revision E</b>
	<b>Effective Date: 10-JAN-2017</b>	<b>Page 37 of 98</b>

## 6.7 Simplified Representations

### 6.7.1 Use of Simplified Representations

Simplified representations (commonly called reps) **shall** be used to improve the regeneration, retrieval, and display times of assemblies to allow the designer to work more efficiently. Refer to Desktop Instruction ED-CAD-DI-005, Simplified Representation Creation and Maintenance, for additional information.

### 6.7.2 Part Simplified Representations

6.7.2.1 The following representation **shall** be used and maintained for each Creo Parametric part:

#### a. **MASTER**

- (1) The MASTER rep **shall** be the deliverable end item for all piece-parts.
- (2) The MASTER rep **shall** represent the model of the part “As-Designed” (not “As-Installed”).
- (3) The MASTER rep **shall** remain the default rep.

6.7.2.2 The following simplified reps may be used and maintained as needed:

#### a. **SIMPLE**

- (1) The SIMPLE rep should remove unnecessary features and represent a basic envelope of the part.
- (2) The SIMPLE rep should be created from the MASTER rep.
- (3) The SIMPLE rep should then be redefined as necessary to exclude features such as rounds, small holes, large patterns, pockets, fasteners, etc. Features that should not be excluded on this rep are features such as major penetrations thru the vehicle skin for vents, feed lines, umbilicals, plumbing, etc.

#### b. **OML**

- (1) The OML rep should represent those components that are visible from outside the vehicle.
- (2) The OML rep should be created from the SIMPLE rep.

### 6.7.3 Assembly Simplified Representations

6.7.3.1 The following simplified reps are required for all assemblies/sub-assemblies and **shall** be used and maintained for each Creo Parametric assembly/subassembly:

#### a. **MAIN**

- (1) The MAIN rep **shall** be the rep that coincides with the EPL.
- (2) The MAIN rep **shall** exclude items such as skeletons and reference geometry.
- (3) The default rep **shall** be the geometry rep for parts and the MAIN rep for assemblies.

**CHECK THE MASTER LIST  
VERIFY THAT THIS IS THE CORRECT VERSION BEFORE USE**

<b>MSFC Technical Standard</b>		
<b>EV32</b>		
<b>Title: Computer-Aided Design (CAD) Standard</b>	<b>Document No.: MSFC-STD-3528</b>	<b>Revision: Revision E</b>
	<b>Effective Date: 10-JAN-2017</b>	<b>Page 38 of 98</b>

b. **EMPTY**

- (1) The EMPTY rep **shall** be completely empty. The EMPTY rep is set to exclude all components.

6.7.3.2 The following simplified reps may be created and maintained for each Creo Parametric assembly/subassembly:

a. **MAIN\_NO\_FASTENERS**

- (1) The MAIN\_NO\_FASTENERS rep should be an exact copy of the MAIN rep with the exception that no fasteners are displayed.  
(2) The MAIN\_NO\_FASTENERS rep should exclude all fasteners.

b. **SIMPLE**

- (1) The SIMPLE rep should include all components in the MAIN rep, including fasteners, with the exception that the SIMPLE rep should have all components with their MASTER reps substituted to SIMPLE reps.

c. **OML**

- (1) The OML rep should have all components set to OML rep.  
(2) Fasteners may be included as required.  
(3) The OML rep should exclude internal components.

6.8 Bulk Items

6.8.1 Bulk items **shall** only exist as a WT Part within ICE Windchill and **shall NOT** have geometry associated to it, except as noted below. Bulk items are defined as any item with a quantity of “As Required” on the EPL. If a bulk item does not exist in ICE Windchill, refer to Desktop Instruction ED-CAD-DI-003, Library Components, for additional information. The -BULK extension **shall** be added to the using assembly number for each instance (e.g., 97M12345-001-BULK1.part).

NOTE: Insulation, solid propellant, and cotter pins are the only exceptions to this requirement when either needs to be modeled for mass properties, clearances, and design considerations for attaching hardware. Refer to Desktop Instruction ED-CAD-DI-025, Bulk Items, for additional information on modeling these exceptions.

## 7. STANDARDIZATION

### 7.1 Setting and Scripts

7.1.1 The following standard settings and supporting data are required to obtain consistent operation of Creo Parametric design software and to perform CAD modeling activities in accordance with this standard. These settings and supporting data **shall** be fully documented and maintained by IES.

**CHECK THE MASTER LIST  
VERIFY THAT THIS IS THE CORRECT VERSION BEFORE USE**

MSFC Technical Standard EV32		
Title: Computer-Aided Design (CAD) Standard	Document No.: MSFC-STD-3528	Revision: Revision E
	Effective Date: 10-JAN-2017	Page 39 of 98

7.1.2 Appropriate client software installation scripts **shall** be maintained that are capable of setting up a standard seat of Creo Parametric design software.

7.1.3 These installation scripts **shall** install and/or configure these standard settings and supporting data for both a client machine located inside the MSFC computer network and for a client machine located outside of the MSFC computer network.

## 7.2 Standard Notes List

7.2.1 A set of standard notes for use on MSFC drawings **shall** be located on a controlled server and maintained by IES.

7.2.2 A standard toolkit **shall** exist that will automate the addition of Common Notes to the drawing.

7.2.2.1 For part drawings (not Altered Item, Envelope, Source Control, or Vendor Item Control drawings, schematics, etc.), the toolkit will place the following notes as the required first notes (Common Notes) on the drawing:

1. GD&T and 14.41 note
2. Burrs and edge break
3. Material
4. Surface Finish
5. Surface treatment/final protective finish
6. Part marking
7. Cleaning
8. Material traceability

7.2.2.2 For assembly drawings, the toolkit will place the following notes as the required first notes (Common Notes) on the drawing:

1. GD&T and 14.41 note
2. Part marking
3. Cleaning
4. Fastener procurement

7.2.2.3 For Altered Item drawings, the toolkit will place the following notes as the required first notes (Common Notes) on the drawing:

1. GD&T and 14.41 note
2. Burrs and edge break
3. Make From note
4. Surface Finish
5. Surface treatment/final protective finish
6. Obliterate vendor part number/re-identify with new number
7. Cleaning

**CHECK THE MASTER LIST  
VERIFY THAT THIS IS THE CORRECT VERSION BEFORE USE**

<b>MSFC Technical Standard EV32</b>		
<b>Title: Computer-Aided Design (CAD) Standard</b>	<b>Document No.: MSFC-STD-3528</b>	<b>Revision: Revision E</b>
	<b>Effective Date: 10-JAN-2017</b>	<b>Page 40 of 98</b>

7.2.2.4 For Source Control drawings, the toolkit will place the following notes as the required first notes (Common Notes) on the drawing:

1. GD&T and 14.41 note
2. No substitution note
3. No guarantee of future availability from the vendor note
4. Approved source(s) note
5. Part marking

7.2.2.5 For Vendor Item Control drawings, the toolkit will place the following notes as the required first notes (Common Notes) on the drawing:

1. GD&T and 14.41 note
2. No substitution note
3. No guarantee of future availability from the vendor note
4. Suggested source(s) note
5. Part marking

7.2.2.6 For Envelope, schematics, and other types of drawings, the designer will select the applicable notes.

7.2.2.7 When Envelope drawings are planned to become Source Control Drawings or Vendor Item Control drawings, the designer **shall** use the Common Notes for Source Control Drawings or Vendor Item Control drawing, respectively.

7.2.3 When any of the Common Notes do not apply, the designer **shall** select Not Applicable instead of deleting that note and replacing it with another. Selecting Not Applicable will place “RESERVED” as the text for that note. Refer to Desktop Instruction ED-CAD-DI-004, Standard Drawing Notes, for additional information, including changes to the Standard Notes List.

### 7.3 Common Parts Library

7.3.1 A Common Parts Library **shall** be maintained to aid designers in the selection of common parts to the greatest extent possible. While not every item a designer needs will be found in the library, this should be the first place a designer looks when selecting parts. The Common Parts Library is comprised of parts that have been commonly used in the past, are known to be flight qualified for certain space flight applications, and are recommended for use in the future. Non-flight library parts are also available for GSE and STE.

7.3.2 The designer **shall** verify the parts are appropriate for a specific application. The availability of parts in the Common Parts Library does not mean a library part can be used for all applications.

7.3.3 Additions/deletions and/or revisions to the Common Parts Library can be made by the designers following the process outlined in the Desktop Instruction ED-CAD-DI-003, Library Components.

**CHECK THE MASTER LIST  
VERIFY THAT THIS IS THE CORRECT VERSION BEFORE USE**



MSFC Technical Standard EV32		
Title: Computer-Aided Design (CAD) Standard	Document No.: MSFC-STD-3528	Revision: Revision E
	Effective Date: 10-JAN-2017	Page 41 of 98

7.3.4 See Appendix B for additional information.

#### 7.4 Symbol Library

7.4.1 A standard symbol library located on a controlled server **shall** be created and maintained by IES.

7.4.2 Standard symbols **shall** be documented in Desktop Instruction ED-CAD-DI-007, Standard Symbols.

7.4.3 See Appendix B for additional information.

#### 7.5 Startup Script

7.5.1 A start up script **shall** be created which automatically copies all MSFC standard configuration files to the user and ensures the latest MSFC approved version of Creo Parametric design software is being utilized.

7.5.2 Creo Parametric design software **shall** always be started using the start up script.

#### 7.6 Configuration Settings

7.6.1 MSFC **shall** create and maintain several standard configuration files that define the setup of Creo Parametric and the way it operates. These files are located on a controlled server and maintained by IES. The following is a list of these files:

7.6.1.1 Config.pro - The config.pro file is a text file that stores all of the settings that define the way in which Creo Parametric handles operations.

7.6.1.1.1 Config.sup - Config.sup is a protected system configuration file. Any values that are set in this file cannot be overridden by other (more local) config.pro or creo\_parametric\_customization.ui file.

7.6.1.2 Creo\_parametric\_customization.- The creo\_parametric\_customization.file is a database file that stores window configuration settings, such as toolbar visibility settings and Model Tree location settings.

7.6.1.3 Drawing Setup (.dtl) File - This file controls the Creo Parametric drafting application. This setup file options determine such characteristics as the height of dimension and note text, text orientation, geometric tolerance standards, font properties, drafting standards, and arrow lengths.

7.6.1.4 Protk.dat file - The protk.dat file adds a menu to the Creo Parametric design software application for running special toolkit applications written specifically for MSFC.

<b>MSFC Technical Standard EV32</b>		
<b>Title: Computer-Aided Design (CAD) Standard</b>	<b>Document No.: MSFC-STD-3528 Effective Date: 10-JAN-2017</b>	<b>Revision: Revision E Page 42 of 98</b>

## **8. PRODUCT LIFECYCLE MANAGEMENT USING ICE WINDCHILL**

### **8.1 ICE Windchill**

8.1.1 The ICE Windchill is a web-enabled Product Lifecycle Management (PLM) tool that provides an infrastructure for management, access, and control of engineering and project data, including documents, CRs, CAD models, CAD drawings, WT Parts, CAD structure, product structure, EPLs, processes, and records.

8.1.2 ICE Windchill **shall** provide a secure, electronic environment to manage and control CAD and WT Part data, including:

- a. Application of automatic version control and retention of previous versions
- b. Locking of objects in specified approval states
- c. Managing the relationship between data objects and processes

8.1.3 ICE Windchill **shall** maintain the controls and relationships between objects and processes as long as the data objects reside within ICE Windchill.

8.1.4 ICE Windchill **shall** provide an electronic Library capability to house standard objects which are utilized across multiple products and assemblies, such as Common Parts and drawing formats.

### **8.2 CAD Entry into ICE Windchill**

8.2.1 ICE Windchill **shall** be used as the PLM tool for product definition.

8.2.2 ICE Windchill **shall** contain all CAD models defining the design.

8.2.3 Creation and maintenance of these files in ICE Windchill **shall** be the responsibility of engineering. Refer to Desktop Instruction ED-CAD-DI-033, Create, Revise, Modify and Promote, and ED-CAD-DI-035, Computer-Aided Design (CAD) Management Prior to Release, for additional information.

### **8.3 CAD Document and CAD Structure Creation in ICE Windchill**

8.3.1 ICE Windchill **shall** automatically create an ICE Windchill CAD Document for each CAD model saved in ICE Windchill.

8.3.2 ICE Windchill **shall** transfer the identity of the CAD model as a part, assembly, or drawing to the ICE Windchill CAD Document.

8.3.3 ICE Windchill **shall** transfer model parameters to the ICE Windchill CAD Document, including number and name fields as specified in Paragraph 5.1.2.

MSFC Technical Standard EV32		
Title: Computer-Aided Design (CAD) Standard	Document No.: MSFC-STD-3528	Revision: Revision E
	Effective Date: 10-JAN-2017	Page 43 of 98

8.3.4 ICE Windchill **shall** replicate the CAD model structure from Creo Parametric and apply those relationships to the CAD Documents in ICE Windchill.

#### 8.4 ICE Windchill Product Areas

8.4.1 CAD document location **shall** be set upon check in to the appropriate ICE Windchill Product folder according to the team assignment and product definition and scope. Refer to Paragraph 8.13.2 and Desktop Instruction ED-CAD-DI-032, Folder Structure, for additional information.

#### 8.5 ICE Windchill CAD Object Versions (Revisions/Iterations)

##### 8.5.1 Version Schemes

8.5.1.1 ICE Windchill object versions are in the format “revision.iteration”. ICE Windchill **shall** contain two version schemes, a numeric version scheme (e.g., 1.1, 1.2; 2.1, 2.2), and an alpha-numeric version scheme (e.g., -.1, -.2; A.1, A.2).

8.5.1.2 The numeric version scheme **shall** be applied to objects that are in a development or pre-release status.

8.5.1.3 The alpha-numeric version scheme **shall** be applied to objects that are being revised prior to submittal for release. The alpha-numeric version scheme applies to all revisions after release.

##### 8.5.2 Numeric Version Scheme

8.5.2.1 ICE Windchill **shall** identify the initial version of each CAD object checked in to ICE Windchill as version 1.1, with each update to that revision adding a new iteration (e.g., 1.1, 1.2, 1.3).

8.5.2.2 When CAD objects are revised, the version **shall** change to 2.1, with each revision adding a new numeric revision (e.g., 2.1, 3.1, 4.1).

##### 8.5.3 Alpha-Numeric Version Scheme

8.5.3.1 When CAD data is ready to be submitted for release, the designer **shall** revise the CAD data to revision dash (-.1) utilizing the instructions in Desktop Instruction ED-CAD-DI-027, Revising CAD Documents and WT Parts.

8.5.3.2 ICE Windchill **shall** reflect a new iteration with each update to that revision (e.g., -.1, -.2, -.3).

8.5.3.3 CAD data **shall** be initially released at revision dash (-).

**CHECK THE MASTER LIST  
VERIFY THAT THIS IS THE CORRECT VERSION BEFORE USE**

MSFC Technical Standard EV32		
Title: Computer-Aided Design (CAD) Standard	Document No.: MSFC-STD-3528	Revision: Revision E
	Effective Date: 10-JAN-2017	Page 44 of 98

8.5.3.4 When released CAD objects are revised, the version **shall** change to A.1, with each revision adding a new alpha revision (e.g., A.1, B.1, C.1).

## 8.6 ICE Windchill Product Structure

8.6.1 The Product Structure within ICE Windchill **shall** match the assembly structure as defined on the top assembly drawing tree or other approved document.

8.6.2 A product structure **shall** be created using WT Parts within ICE Windchill.

8.6.3 Each WT Part **shall** be created on ICE Windchill to represent all parts on the EPL. A “part” may refer to any detail part, assembly, or sub-assembly.

8.6.4 A WT Part **shall** have a part number as defined in Paragraph 5.7.

8.6.5 A WT Part **shall** only have one “owner” association to the CAD Document for the part.

8.6.6 This “owner” association to the CAD Document **shall** be considered the “master” definition of the part.

8.6.7 Additional CAD documents can have a “content” association to the WT Part as needed.

8.6.8 A WT Part that is to be linked to other WT Parts outside of its product is typically an “End Item” and will have a special WT Part object assigned.

8.6.9 The product structure for a WT Part **shall** include all related WT Parts needed to capture a complete design definition and will represent the engineering Bill of Materials (BOM) or EPL.

8.6.10 The product structure **shall** capture the definition of the following items:

- a. Part Number
- b. Part Description
- c. Part Quantity
- d. Alternate or Substitute Parts
- e. Reference Designations
- f. Find Number for its associated drawing for assemblies

## 8.7 ICE Windchill Relationships Built Through Product Structure

8.7.1 Refer to MSFC-STD-555 Appendix L for details on relationships built through product structure.

MSFC Technical Standard EV32		
Title: Computer-Aided Design (CAD) Standard	Document No.: MSFC-STD-3528	Revision: Revision E
	Effective Date: 10-JAN-2017	Page 45 of 98

## 8.8 WT Part Digital Data Sets

### 8.8.1 Primary Model (“As-Designed”)

8.8.1.1 The primary model of a WT Part **shall** represent the model of the part in its “As-Designed” condition when opened using the CAD File’s MASTER rep for parts and MAIN rep for assemblies. Refer to Paragraphs 6.7 and 12.1 for additional information.

8.8.1.2 WT Parts designed by MSFC **shall** include a 3-Dimensional (3D) model representing the “As-Designed” condition of the part design.

8.8.1.3 WT Parts designed by MSFC **shall** include a drawing containing all information necessary for fabrication, finish, marking and inspection except where required by business practices or by Creo Parametric limitations as a minimum.

8.8.1.4 Each Find Number shown on a drawing **shall** have its own WT Part object.

8.8.1.5 Digital data sets associated to each WT Part **shall** include all required dependencies to other CAD Documents as needed to fully capture and maintain the WT Part’s design definition. Other Documents can be associated to a WT Part object on ICE Windchill to fully define the design definition of the WT Part.

### 8.8.2 Related Models

8.8.2.1 CAD Documents that do not define the primary model definition of a WT Part but which are required to fully define or maintain the design definition of the same WT Part **shall** have a “content” association to each WT Part. An example of a CAD Document would be an ICD skeleton file. Refer to Paragraph 8.6 for additional information.

8.8.2.2 Models representing earlier designed conditions which are not defined by a WT Part may utilize a forward inheritance, backward inheritance or family table method as appropriate.

8.8.2.3 Companion Files **shall** have a “content” association to the WT Part object for the primary model by the same part number. Refer to Paragraph 5.4 for list of companion files.

8.8.2.4 Drawing Files **shall** have a “content” association to a WT Part object and may be used to document one or more parts.

8.8.2.5 The following types of drawings (per 7.8.7 of GDRM) **shall** have a “content” association to their referenced WT Part object, but may not have their own WT Part:

- a. Schematics
- b. Wiring Diagrams
- c. Logic Diagrams
- d. Elevation Drawings
- e. Connection Drawings

**CHECK THE MASTER LIST  
VERIFY THAT THIS IS THE CORRECT VERSION BEFORE USE**

<b>MSFC Technical Standard EV32</b>		
<b>Title: Computer-Aided Design (CAD) Standard</b>	<b>Document No.: MSFC-STD-3528</b>	<b>Revision: Revision E</b>
	<b>Effective Date: 10-JAN-2017</b>	<b>Page 46 of 98</b>

f. Printed Wiring Master Pattern

Refer to MSFC-STD-555 Appendix I2.1 for when a WT Part is required.

8.9 ICE Windchill Baselines

8.9.1 Any End Item from a product should have an ICE Windchill baseline produced immediately after the End Item has been promoted to the Workgroup Approved lifecycle state. The creator of this baseline is responsible for gathering and capturing ALL dependencies based upon the model structure using the Engineering Development Configuration. Refer to Paragraph 8.10.1.1.

8.9.2 ICE Windchill Baselines for CAD design work **may** be captured by the designer at the following points. The creator of this baseline is responsible for gathering and capturing REQUIRED dependencies based upon the model structure.

- a. End of design cycle
- b. Export of data outside ICE Windchill
- c. Prior to WGA for assemblies or non-latest revisions of parts
- d. Prior to Review (PDR, CDR, etc.)
- e. Prior to Release
- f. "As-Designed" baseline
- g. Other designated times

8.9.3 Information on Baseline Creation and Management can be found in the MSFC CAD Tips and Best Practices library in ICE Windchill.

8.9.4 See Appendix B for additional information.

8.10 Configurations (Options for Gathering Data within ICE Windchill)

8.10.1 Description of Configuration for Designers:

8.10.1.1 Latest

- a. **Shall** be used to collect the latest version of CAD and WT Parts for which the user has access.
- b. Will only collect Design or higher lifecycle states for products to which the user is only a member.
- c. Is the default configuration specification and **shall** be used for most current engineering activities.

<b>MSFC Technical Standard EV32</b>		
<b>Title: Computer-Aided Design (CAD) Standard</b>	<b>Document No.: MSFC-STD-3528</b>	<b>Revision: Revision E</b>
	<b>Effective Date: 10-JAN-2017</b>	<b>Page 47 of 98</b>

#### 8.10.1.2 ICE Windchill Baseline

- a. May be used to collect the precise versions of CAD and WT Parts as listed in the specified ICE Windchill Baseline.
- b. User must specify a baseline previously created to use this method.
- c. The specific version of the initial object selected must be in the baseline.

#### 8.10.1.3 Latest Design

- a. May be used to collect the latest version of CAD and WT Parts which are in the Design lifecycle state. This is a manual process performed by the designer.

#### 8.10.1.4 Latest Workgroup Approved

- a. May be used to collect the latest version of CAD and WT Parts which are in the Workgroup Approved lifecycle state. This is a manual process performed by the designer.

#### 8.10.1.5 Latest Released

- a. May be used to collect the latest version of CAD and WT Parts which are in the Released lifecycle state. This is a manual process performed by the designer. Refer to Desktop Instruction ED-CAD-DI-030, Gathering Released Data in ICE Windchill, for additional information on how to gather data for previously released versions as well as the latest released.

#### 8.10.1.6 Released by Effectivity

- a. **Shall** be used to collect the precise version of CAD and WT Parts effective for an End Item. This is a manual process performed by the designer.
- b. This collection rule **shall** be used for gathering data for the following cases:
  - (1) Manufacturing, Flight Readiness Reviews.
  - (2) Creation of effective “As-Designed” Baseline.

8.10.2 Information on Data Collection and Configuration Specifications can be found in the MSFC CAD Tips and Best Practices library in ICE Windchill.

8.10.3 Refer to Desktop Instruction ED-CAD-DI-011, Data Transfer, for additional information.

8.10.4 See Appendix B for additional information.

#### 8.11 Engineering Parts List

8.11.1 The EPL **shall** be generated as a report within ICE Windchill.

<b>MSFC Technical Standard EV32</b>		
<b>Title: Computer-Aided Design (CAD) Standard</b>	<b>Document No.: MSFC-STD-3528</b>	<b>Revision: Revision E</b>
	<b>Effective Date: 10-JAN-2017</b>	<b>Page 48 of 98</b>

8.11.2 Find numbers **shall** match the appropriate callouts on the drawing at WGA, other project specified points at which a baseline is created, and at release.

8.11.3 Find numbers in the EPL **shall** NOT be re-ordered or re-assigned after the drawing and its associated EPL are formally released and under CM, including those that are assigned using a repeat region in a table.

8.11.4 Advanced Parts Lists **shall** consist of WT Parts without any CAD documents associated to them.

## 8.12 Lifecycle Scheme

8.12.1 Lifecycle states are associated to all objects in ICE Windchill (documents, CAD documents, WT Parts).

## 8.13 Access Methodology

### 8.13.1 General Requirements

8.13.1.1 Data accessed within ICE Windchill Products **shall** be controlled by Product Team Roles, Lifecycle States and Folders.

8.13.1.2 Additionally, object based access control for CAD Documents and WT Parts **shall** be implemented using the Sensitive But Unclassified (SBU) restrictions described in Paragraph 8.16.

### 8.13.2 Access by Folder

#### 8.13.2.1 Product Folder

- a. **Shall** contain the latest CAD and WT Parts for the product under development.
- b. Only members with product roles of Access CAD 5, 6, and 7 **shall** modify data in this folder.

#### 8.13.2.2 Control Folder

- a. **Shall** contain controlling CAD and WT Parts such as Interface Control Files and Skeleton Files.
- b. Only members with product roles of Access CAD 6 and 7 **shall** modify data in this folder.

#### 8.13.2.3 Trades Folder

- a. **Shall** contain alternate or out of date CAD and WT Parts and data not yet intended for general product development team consideration.

**CHECK THE MASTER LIST  
VERIFY THAT THIS IS THE CORRECT VERSION BEFORE USE**



<b>MSFC Technical Standard EV32</b>		
<b>Title: Computer-Aided Design (CAD) Standard</b>	<b>Document No.: MSFC-STD-3528 Effective Date: 10-JAN-2017</b>	<b>Revision: Revision E Page 49 of 98</b>

b. Only members with product roles of Access CAD 5, 6, and 7 **shall** modify data in this folder.

### 8.13.3 Access by Lifecycle State

#### 8.13.3.1 In Work

a. CAD and WT Parts in the “In Work” lifecycle state **shall** be visible and modifiable by members with Product roles of Access CAD 4, 5, 6, and 7 based upon folder access in Para. 8.13.2.

b. CAD and WT Parts in the “In Work” lifecycle state **shall** be visible to personnel in the Access CAD 3, Read-Download for In Work, Product team role.

c. CAD and WT Parts in the “In Work” lifecycle state **shall** NOT be visible to personnel in any other Product team roles.

#### 8.13.3.2 Design

a. Members with Product roles of Access CAD 2 and 3 **shall** have Read and Download access CAD and WT Parts in Design State. Members with Product roles of Access CAD 4 and 5 **shall** be able to Read and Revise CAD and WT Parts in Design State. Members with Product roles of Access CAD 6 & 7 **shall** be able to Modify, Revise, and Rename CAD and WT Parts in Design State.

b. CAD and WT Parts **shall** be visible but not modifiable to all confirmed members of the ICE Windchill Product.

#### 8.13.3.3 Pending Approval

a. Members with Product roles of Access CAD 2 through 7 **shall** be able to Read CAD and WT Parts in the Pending Approval state.

b. CAD and WT Parts **shall** be visible but not modifiable to all confirmed members of the ICE Windchill Product.

#### 8.13.3.4 Workgroup Approved

a. Members with Product roles of Access CAD 1, 2, 3 **shall** be able to Read and Download CAD and WT Parts in the Workgroup Approved state. Members with Product roles of Access CAD 4 and 5 **shall** be able to Read and Revise CAD and WT Parts in the Workgroup Approved state.

b. CAD and WT Parts **shall** be visible but not modifiable to all confirmed members of the ICE Windchill Product.

**CHECK THE MASTER LIST  
VERIFY THAT THIS IS THE CORRECT VERSION BEFORE USE**

<b>MSFC Technical Standard EV32</b>		
<b>Title: Computer-Aided Design (CAD) Standard</b>	<b>Document No.: MSFC-STD-3528</b>	<b>Revision: Revision E</b>
	<b>Effective Date: 10-JAN-2017</b>	<b>Page 50 of 98</b>

#### 8.13.3.5 Under Review

- a. Members with Product roles of Access CAD 4, 5, and 6 **shall** be able to Read and Modify CAD and WT Parts in the Under Review state.
- b. CAD and WT Parts **shall** be visible but not modifiable to all confirmed members of the ICE Windchill Product.

#### 8.13.3.6 Workgroup Approved Rework

- a. Members with Product roles of Access CAD 2 and 3 **shall** be able to Read and Download CAD and WT Parts in the Workgroup Approved Rework state based upon folder access in Para. 8.13.2. Members with Product roles of Access CAD 4, 5, 6 and 7 **shall** be able to Modify, Rename, and Revise CAD and WT Parts in the Workgroup Approved Rework state.
- b. CAD and WT Parts **shall** NOT be visible to members with Product roles of Access CAD 1.

#### 8.13.3.7 Released

- a. CAD and WT Parts **shall** be visible and revisable by members with Product roles of Access CAD 4, 5, 6 and 7.
- b. CAD and WT Parts **shall** be visible but not modifiable to all confirmed members of the ICE Windchill Product.

#### 8.14 Workgroup Approval (WGA)

8.14.1 The WGA CR process may be used to perform a pre-release review of CAD and WT Parts.

#### 8.15 Release

##### 8.15.1 Initiation

8.15.1.1 Design release (both initial release and change release) **shall** be initiated by an ICE Windchill CR. Refer to-MSFC-STD-555 Section 4.6.2, and ED-CAD-DI-036, Preparation and Processing of an ICE Windchill Change Request for CAD and WT Part Release, for additional information.

##### 8.15.2 Initial Release

8.15.2.1 Design packages for initial release **shall** include the following items for each part being released:

- a. WT Part

**CHECK THE MASTER LIST  
VERIFY THAT THIS IS THE CORRECT VERSION BEFORE USE**

MSFC Technical Standard EV32		
Title: Computer-Aided Design (CAD) Standard	Document No.: MSFC-STD-3528	Revision: Revision E
	Effective Date: 10-JAN-2017	Page 51 of 98

- b. “As-Designed” CAD model object with an “owner” association to the WT Part
- c. CAD drawing object which has a “content” association to the WT Part
- d. Other CAD documents necessary for complete product definition of the WT Part, including all companion files, which have a “content” association to the WT Part.

### 8.15.3 Changes to Released Design

- 8.15.2.1 Changes to released design **shall** be documented in revisions to the released objects.
- 8.15.2.2 The revised objects **shall** be submitted for release by an ICE Windchill CR.
- 8.15.2.3 The ICE Windchill CR for design change release **shall** include detailed change descriptions for each object included in the change package.

### 8.16 Security (SBU)

- 8.16.1 SBU restrictions **shall** prevent access for certain user groups even though they otherwise meet the access requirements for Paragraph 8.13.
- 8.16.2 Designers/Engineers **shall** NOT use personal and/or home directories to store SBU files created for any project or program.

### 8.17 Viewables

- 8.17.1 ICE Windchill **shall** create viewables of all solid geometry and drawings in the “As-Stored” configuration upon check-in.
- 8.17.2 The designer **shall** ensure that viewables of all drawings are created prior to the WGA process and release process.
- 8.17.3 See Appendix B for additional information.

### 8.18 Expedited Changes to Released Data

Expedited changes to released drawings and EPLs can be accomplished through the use of Floor Engineering Orders and Floor Engineering Parts Lists. Refer to MSFC-STD-555 Appendix P for details on floor changes.

<b>MSFC Technical Standard EV32</b>		
<b>Title: Computer-Aided Design (CAD) Standard</b>	<b>Document No.: MSFC-STD-3528</b>	<b>Revision: Revision E</b>
	<b>Effective Date: 10-JAN-2017</b>	<b>Page 52 of 98</b>

## **9. DESIGN METHODOLOGY**

Design activities can be accomplished using Bottom-Up Design Methodology, Top-Down Design Methodology or a combination of the two.

### **9.1 Guidelines for Selecting Design Methodology**

9.1.1 When all parts are to be independent during the entire design cycle, Bottom-Up Design Methodology should be used. Refer to Section 10 for detailed information.

9.1.2 When wanting to control geometry and/or location of multiple parts parametrically using skeletons during the development of the design, Top-Down Design Methodology should be used.

9.1.2.1 The type of Top-Down Design Methodology used **shall** be Modular Product Architecture methodology. Refer to Section 11 for detailed information.

9.1.2.2 All external references **shall** be set to “Independent” prior to release.

## **10. BOTTOM-UP DESIGN METHODOLOGY**

10.1 External references shall NOT exist in the models, except for Creo Piping and Creo Cabling which may make external references to skeleton models located within the respective cabling or piping assembly ONLY.

10.1.1 External references may be used to provide a temporary guide during feature creation, but **shall** then be removed from the model immediately. (See Section 13.4.2)

10.2 Skeleton files and Creo Parametric Design layouts **shall** NOT be used to drive geometry.

10.2.1 Locator skeleton files and Creo Parametric Design layouts may be used to drive location and/or orientation. See Section 11.2 for details.

10.3 During creation of an assembly, constraining the parts with actual mating features is recommended. Coordinate systems and datum features may be used for constraining components.

10.4 Inheritance features are allowed as defined in Sections 8.8.2.2, 12.1.2, and 12.15.

10.5 Part family tables are allowed. Part family tables **shall** NOT be broken into single stand-alone parts.

<b>MSFC Technical Standard EV32</b>		
<b>Title: Computer-Aided Design (CAD) Standard</b>	<b>Document No.: MSFC-STD-3528</b>	<b>Revision: Revision E</b>
	<b>Effective Date: 10-JAN-2017</b>	<b>Page 53 of 98</b>

## **11. MODULAR PRODUCT ARCHITECTURE (MPA)**

The MPA process involves the explicit identification and management of interfaces using skeletons.

### **11.1 General Requirements**

11.1.1 The MPA process may be used as a tool to coordinate location and interface definition during design development but all external references **shall** be set to “Independent” prior to release.

### **11.2 Locator Skeletons**

11.2.1 Locator skeletons are used for location and orientation of interfaces. They **shall NOT** be used to drive parts or other skeletons, including routing, unless the components have multiple interfaces.

11.2.2 Publish geometry sets within locator skeletons should contain coordinate systems only.

11.2.3 Locator skeletons **shall** contain the minimum features necessary to define locator coordinate systems.

11.2.4 Locator skeletons **shall NOT** contain external references.

11.2.5 Locator skeletons **shall NOT** contain solid geometry.

### **11.3 Interface Control Skeletons**

11.3.1 Interface control skeletons are stand alone files.

11.3.2 Interface control skeletons **shall** only control geometry and NOT location.

11.3.3 An interface control skeleton **shall** control only one interface.

11.3.4 Interface control skeletons **shall NOT** contain solid geometry.

### **11.4 Model Requirements**

11.4.1 Models **shall** contain external references that are only dependent upon publish geometry features from locator or interface control skeletons, except for bolt hole pattern axes.

11.4.1.1 Additional external references may be used to provide a temporary guide during feature creation, but **shall** then be removed from the model immediately. (See Section 13.4.2)

<b>MSFC Technical Standard EV32</b>		
<b>Title: Computer-Aided Design (CAD) Standard</b>	<b>Document No.: MSFC-STD-3528</b>	<b>Revision: Revision E</b>
	<b>Effective Date: 10-JAN-2017</b>	<b>Page 54 of 98</b>

11.4.2 Parameters and relations **shall** be controlled at the part level and NOT by other parts, assemblies or layouts.

11.4.3 One skeleton **shall** NOT be used for more than one routed line.

11.4.4 ModelCHECK **shall** be run prior to release to verify all external references have been set to “Independent”.

11.4.5 Refer to the following Desktop Instructions for details on implementing MPA:

- ED-CAD-DI-034 Modular Product Architecture
- ED-CAD-DI-028 Physical Interface Matrix Creation
- ED-CAD-DI-006 Creation of Skeleton Files

## **12. PART MODELING**

### 12.1 Modeling Requirements

12.1.1 All geometry **shall** be created at full scale.

12.1.2 For the creation of the “As-Designed” model and any part model used in the MAIN rep of assemblies, the following applies:

12.1.2.1 The model **shall** contain the complete feature history.

- a. Features as modeled should remain in the model tree.
- b. Files **shall** NOT be exported to a neutral format and then imported to clean up features or dependencies. This does not apply to vendor items.
- c. Copy Geometry features are acceptable within the model providing they are set to “Independent” prior to promoting the model to the “Design” state, WGA, and release.
- d. Inheritance features are acceptable within the model providing they are set to “Independent” prior to promoting the model to the “Design” state, WGA and release.

12.1.2.2 All additional part conditions needed for design definition **shall** be captured in companion files and not within simplified representations.

12.1.2.3 Opposite models **shall** be created as a dependent mirror model and **shall** define a master model and a related WT Part.

12.1.2.4 An inheritance between different WT Parts **shall** only be used for a “Make from” condition. An example of this use is applicable for castings to the final machined part.

**CHECK THE MASTER LIST  
VERIFY THAT THIS IS THE CORRECT VERSION BEFORE USE**

<b>MSFC Technical Standard EV32</b>		
<b>Title: Computer-Aided Design (CAD) Standard</b>	<b>Document No.: MSFC-STD-3528</b>	<b>Revision: Revision E</b>
	<b>Effective Date: 10-JAN-2017</b>	<b>Page 55 of 98</b>

12.1.2.5 Family table parts **shall** be used only with tabulated drawings, parts with flat and formed states, within Common parts libraries, or as definition of companion files within a data set. Refer to Desktop Instruction ED-CAD-DI-013, Standard Barrel Panels, for additional information on using family tables to define parts with flat and formed states.

12.1.2.6 Small features such as the standard edge breaks, small inside corner radii, small machined radii, etc., **shall** NOT be added to the model. These **shall** be captured with a general note on the drawing. Examples: Top edge of o-ring grooves, inside corner radii.

## 12.2 Design Intent

12.2.1 Models **shall** be created such that if a feature is modified, all related features update accordingly.

12.2.2 Models **shall** have no frozen features.

12.2.3 Models **shall** have no suppressed features unless required by family tables.

12.2.4 All extraneous entities should be deleted. An extraneous entity would be any entity that is not needed in the definition of the model geometry.

## 12.3 Part Initialization

12.3.1 Before beginning a part model, the designer should look for a similar part to copy, mirror, or save from, when applicable.

12.3.2 The existing model **shall** first be evaluated for proper construction before it is copied, mirrored or saved from.

## 12.4 Model Creation

12.4.1 In order to maintain good downstream usage, the part **shall** be created at the designer's discretion in the following manner:

### 12.4.1.1 Primary Feature Level

- a. Primary level features comprise the functional features of the part. These features include alignment, range of motion, and housing features.
- b. Examples: Major bores, datum features, interface surfaces, skeletons, etc.

### 12.4.1.2 Secondary Feature Level

- a. Secondary level features are comprised of features that allow the part to be assembled to

**CHECK THE MASTER LIST  
VERIFY THAT THIS IS THE CORRECT VERSION BEFORE USE**

MSFC Technical Standard EV32		
Title: Computer-Aided Design (CAD) Standard	Document No.: MSFC-STD-3528	Revision: Revision E
	Effective Date: 10-JAN-2017	Page 56 of 98

other parts, provide clearance with other parts, and reduce the weight of the part.

b. Examples: Holes, lightening cutouts, clearance cuts, etc.

#### 12.4.1.3 Tertiary Feature Level

a. Tertiary features are comprised of finishing features, such as rounds, fillets, chamfers, drafts and similar details not required for function.

### 12.5 Sketcher

12.5.1 The designer **shall** select the feature type and attributes that best define design intent and intelligence of a feature.

12.5.2 Sketch entities should be created inside, rather than outside the existing part boundaries when cutting away material.

12.5.3 The designer **shall** verify that the sketch is “Fully Constrained”.

12.5.4 All sketcher dimensions **shall** be locked after the sketch is completed.

### 12.6 Part/Sketcher Relations

12.6.1 Relations may be used when necessary in part models to help facilitate proper design intent. When relations are used, comments **shall** be added to describe the expression.

12.6.2 All errors **shall** be removed from the relations field.

12.6.3 Refer to Paragraph 6.6 for further information.

### 12.7 Feature References

12.7.1 The design intent of the model **shall** drive the designer’s choice of feature references.

12.7.2 When selecting feature references, the designer should select the foundation features when possible.

12.7.2.1 The order in which the designer should select feature references is datums, surfaces, or edges.

12.7.2.2 Edge references should be avoided if possible, by selecting datums or surfaces.

12.7.3 Features other than the default datums that are frequently referenced should be named something logical and meaningful to the designer so that they might be found using the search tool.

**CHECK THE MASTER LIST  
VERIFY THAT THIS IS THE CORRECT VERSION BEFORE USE**



<b>MSFC Technical Standard EV32</b>		
<b>Title: Computer-Aided Design (CAD) Standard</b>	<b>Document No.: MSFC-STD-3528</b>	<b>Revision: Revision E</b>
	<b>Effective Date: 10-JAN-2017</b>	<b>Page 57 of 98</b>

12.7.4 All external dependencies within the model **shall** be up-to-date and set to “Independent” prior to promoting the model to the “Design” state and prior to submitting the model for WGA and release.

## 12.8 Feature Modification/Verification

12.8.1 If a part is modified, it **shall** be verified at the next assembly level to ensure that no failures have occurred.

12.8.2 Drawing and companion files **shall** be verified to update without failures or missing details.

## 12.9 Part Assembly Datums

12.9.1 The designer **shall** add datum features, such as planes, axes, and coordinate systems, to aid in placement at the assembly level.

12.9.2 The designer **shall** name these features accordingly so that they will not accidentally be deleted.

## 12.10 Named Views and Cross-Section Datums

12.10.1 Separate datum planes should be created for named and cross-section views used on the detail drawing.

12.10.2 If Datum Planes are created for named views, they **shall** be renamed to “**view\_viewname**”. For example, View A would be renamed “view\_A”.

12.10.3 If Datum Planes are created for cross-section views, they **shall** be renamed to “**sec\_sectionname**”. For example, Section A-A would be renamed “sec\_A”.

12.10.4 Datum planes **shall** NOT be frozen or suppressed due to missing placement references.

## 12.11 Family Tables

12.11.1 Family table columns **shall** be renamed to clearly represent the information contained in the tabulated table.

12.11.2 Family tables **shall** be verified before they are checked into ICE Windchill.

12.11.3 Family table fields **shall** NOT be populated with an asterisk. The actual value must be inserted.

**CHECK THE MASTER LIST  
VERIFY THAT THIS IS THE CORRECT VERSION BEFORE USE**

<b>MSFC Technical Standard EV32</b>		
<b>Title: Computer-Aided Design (CAD) Standard</b>	<b>Document No.: MSFC-STD-3528</b>	<b>Revision: Revision E</b>
	<b>Effective Date: 10-JAN-2017</b>	<b>Page 58 of 98</b>

12.11.4 Family tables **shall** NOT be nested.

## 12.12 Holes

12.12.1 Threaded hole thread depth and tap drill depth **shall** be modeled to the mean of the tolerance zone as shown on the drawing.

12.12.2 External and internal threads **shall** be modeled as follows:

12.12.2.1 Internal Thread: Hole is nominal tap drill size

12.12.2.2 External Thread: Shaft diameter is nominal major diameter

12.12.3 Detail screw threads **shall** NOT be modeled as helixes but **shall** instead be defined by the applicable specification, unless the thread form must be shown in order to fully specify thread definition or when required for feature orientation. The threads should be modeled as a hole with a flag note callout on the drawing to specify the thread details.

12.12.4 Drilled/reamed holes may be modeled using the Recommended Holes Sizes in Appendix F and use positive unilateral tolerances.

12.12.5 Drilled holes should be created using the hole command.

## 12.13 Rounds and Chamfers

12.13.1 The designer should place rounds and chamfers at the Tertiary Feature level.

12.13.2 The designer **shall** NOT include different dimensional values in the same feature except for variable rounds.

12.13.3 Rounds and chamfers should be created using “Intent edges” first, then by the “Multi” selection tool.

12.13.4 Rounds and chamfers should be created using the rounds and chamfers command.

12.13.5 Rounds and chamfers **shall** NOT have children. Exceptions to this requirement are given in Desktop Instruction ED-CAD-DI-026, Verifying 3-Dimensional CAD Models.

12.13.6 See Appendix B for additional information.

MSFC Technical Standard EV32		
Title: Computer-Aided Design (CAD) Standard	Document No.: MSFC-STD-3528	Revision: Revision E
	Effective Date: 10-JAN-2017	Page 59 of 98

#### 12.14 Drafts

12.14.1 The designer should place drafts at the Tertiary Feature level. If a draft cannot be applied using the draft functionality, it can be added to the sketch as necessary.

12.14.2 Draft should be created using “Intent surfaces” first, then by the “Multi” selection tool.

#### 12.15 Castings and Forgings

12.15.1 The designer should create casting and forgings models using the “Inheritance” functionality of Creo Parametric design software.

12.15.2 Refer to Desktop Instruction ED-CAD-DI-012, Casting and Forging Creation, for additional information.

#### 12.16 Piping/Cabbling

12.16.1 These modules have pre-defined cables/fittings and pipe stock. The designer **shall** insert these files from the standard library.

12.16.2 If a standard part does not exist in ICE Windchill, refer to Desktop Instruction ED-CAD-DI-003, Library Components, for additional information.

12.16.3 Refer to Desktop Instructions ED-CAD-DI-014, Cable Routing, and ED-CAD-DI-015, Piping, for additional information.

#### 12.17 Sheet Metal

12.17.1 Flat Patterns **shall** be created to support drawing creation and for use by manufacturing.

12.17.2 A family table instance **shall** be created of the flat pattern and named in accordance with Section 5.

12.17.3 Refer to Desktop Instruction ED-CAD-DI-018, Sheet Metal Parts, for additional information.

#### 12.18 User Defined Features (UDF)

12.18.1 A UDF **shall** be inserted from the standard UDF library within ICE Windchill if available.

12.18.2 A UDF **shall** be un-grouped after insertion to break the link with the .GPH file.

12.18.3 If a UDF does not exist in the standard UDF library and may be useful to others, refer to Desktop Instruction ED-CAD-DI-020, User Defined Features, for additional information.

**CHECK THE MASTER LIST  
VERIFY THAT THIS IS THE CORRECT VERSION BEFORE USE**

MSFC Technical Standard EV32		
Title: Computer-Aided Design (CAD) Standard	Document No.: MSFC-STD-3528	Revision: Revision E
	Effective Date: 10-JAN-2017	Page 60 of 98

## 12.19 Gears, Splines and Sprockets

12.19.1 All gear, spline, or sprocket models **shall** be created to fully define the part.

12.19.2 The SIMPLE part rep will suppress the display of gear, spline, and sprocket tooth features to simplify viewing at upper level assemblies.

12.19.3 Refer to Desktop Instruction ED-CAD-DI-021, Gears, Splines, and Sprockets, for additional information.

## 12.20 Variable Geometry Components

12.20.1 A variable geometry component is one that can be used in more than one configuration or shape. The designer **shall** create a -MOD part that is placed into the assembly at the “As-Installed” or fabricated condition. The -MOD extension **shall** be added to the vendor part number for non-bulk items and the WT Part for the component **shall** be empty.

12.20.2 The designer **shall** verify that all variations of the component are identical except for shape. Examples: Electrical components with a pigtail; ground straps; seals; and hose assemblies. Refer to Desktop Instruction ED-CAD-DI-031, Ground Strap Creation, for additional information.

## 12.21 Pro/PROGRAM™

12.21.1 Pro/PROGRAM™ may be used at the designer’s discretion to help resolve part and assembly issues.

## 12.22 Composite Parts

12.22.1 Composite Parts **shall** be modeled as a solid.

12.22.2 Each ply boundary **shall** be defined by a curve projected normal onto its layup surface.

12.22.3 Each ply boundary curve **shall** be named as follows: PLYxxxx, where xxxx represents a four digit number. The ply boundary curves should be numbered by tens initially (PLY0010, PLY0020, PLY0030, etc.) to allow for new plies to be inserted later and the ply boundary curves still be in numerical order.

NOTE: If Fibersim® is used for ply generation, follow ED-CAD-DI-029 for instruction on layer naming.

12.22.4 Each ply boundary curve **shall** be placed on a separate user-defined layer, with the name corresponding to the ply name and the layer hidden when checked into ICE Windchill. For example, PLY0010 will be on layer 99\_PLY0010. When ply boundaries are exactly the same,

**CHECK THE MASTER LIST  
VERIFY THAT THIS IS THE CORRECT VERSION BEFORE USE**

MSFC Technical Standard EV32		
Title: Computer-Aided Design (CAD) Standard	Document No.: MSFC-STD-3528	Revision: Revision E
	Effective Date: 10-JAN-2017	Page 61 of 98

they may be placed on a single layer with the layer named 99\_PLY(first layer)-(last layer), where (first layer) and (last layer) correspond to the appropriate four digit numbers.

NOTE: If Fibersim® is used for ply generation, follow ED-CAD-DI-029 for instruction on layer naming.

12.22.5 The tooling surface definition **shall** be extended a minimum of six inches beyond the edges of the part, placed on a user-defined layer named 99\_TOOLING\_SURFACE, and the layer hidden when checked into ICE Windchill.

12.22.6 Refer to Desktop Instruction, ED-CAD-DI-029, Modeling of Composites, for additional information on modeling techniques for composites.

### 12.23 Creo Parametric Layouts

12.23.1 Creo Parametric layouts may be used during design development or to support trade studies. If used, Creo Parametric layouts **shall** be undeclared prior to release, but should remain declared until the design is frozen or complete.

### 12.24 Envelope Models

This section is applicable to models of vendor items that will be procured through Envelope, Source Control, and Vendor Item Control drawings. This section is not applicable to vendor items in the standard library or –ENV companion files created to show the OML of an item only. The term “envelope model” is used to refer to the model for Envelope, Source Control, and Vendor Item Control drawings. Refer to Section 14.3.15 for detailed drawing requirements.

12.24.1 An envelope assembly model **shall** be created to represent the reserved volume and interface requirements, when defined.

12.24.1.1 Datum features **shall** be created in the envelope assembly model for component constraints.

12.24.1.2 An –ENV envelope companion file **shall** be created to represent the overall reserved volume.

12.24.1.3 When a vendor model has been received, the vendor model **shall** be added to the envelope assembly model. Refer to Desktop Instruction ED-CAD-DI-022, Vendor Item Modeling, for information on converting the vendor-supplied model to use in the envelope assembly model.

12.24.1.4 The envelope assembly model (.asm) **shall** have the –ENV envelope companion file assembled until the Source Control/Vendor Item Control drawing is released.

12.24.2 The envelope assembly model **shall** be named in accordance with Section 5. This is not a companion file and will have its own part number.

**CHECK THE MASTER LIST  
VERIFY THAT THIS IS THE CORRECT VERSION BEFORE USE**

MSFC Technical Standard EV32		
Title: Computer-Aided Design (CAD) Standard	Document No.: MSFC-STD-3528	Revision: Revision E
	Effective Date: 10-JAN-2017	Page 62 of 98

12.24.3 The envelope assembly model **shall** be assembled in the using assembly.

12.24.4 The envelope assembly model **shall** have an “owner” association its own WT Part, and its component and drawing **shall** have a “content” association.

12.24.5 The –ENV envelope companion file model **shall** include the following when available:

- The geometry reserved for the part regardless of the vendor
- Mass properties
- Mounting hole patterns
- Electrical/fluid connections with reference designation labels
- Any key structural/mechanical interface
- Any required clearances for interfaces (e.g., wrench clearances)

12.24.6 Notional CAD models representing potential vendor models **shall** NOT be released.

## 13. ASSEMBLY MODELING

### 13.1 Start Assembly

13.1.1 The MSFC standard “Start Assembly” **shall** be used when creating a new assembly. The start files contain the foundation features (default datums, csys, parameters, views, and layers) that will ensure cross-departmental consistency.

13.1.2 The foundation features **shall** NOT be deleted or renamed in the assembly model for any reason.

### 13.2 Skeleton Parts

13.2.1 The skeleton part **shall** contain the foundation features by utilizing the MSFC standard start part.

### 13.3 Assembly Level Dependencies

13.3.1 Lateral dependencies **shall** NOT be used for dimensional or relational constraints in the assembly model.

13.3.2 All external dependencies within the model **shall** be up-to-date and be set to “Independent” prior to promoting to Design State, WGA and release.

### 13.4 Assembly Created Features

13.4.1 The designer **shall** NOT create assembly level cuts, holes, or any other feature that removes material.

**CHECK THE MASTER LIST  
VERIFY THAT THIS IS THE CORRECT VERSION BEFORE USE**

MSFC Technical Standard EV32		
Title: Computer-Aided Design (CAD) Standard	Document No.: MSFC-STD-3528	Revision: Revision E
	Effective Date: 10-JAN-2017	Page 63 of 98

13.4.2 Copy geometry may be used to provide a guide during feature creation, but **shall** then be removed from the model.

13.4.3 The designer **shall** assemble the –MOD or as-fabricated part where applicable. Refer to Desktop Instruction ED-CAD-DI-009, MOD File Creation, for additional information.

### 13.5 Component Placement Constraints

13.5.1 All components **shall** be fully constrained when placed in an assembly. Components used in mechanisms may be packaged depending on their function.

13.5.2 Packaged components **shall** NOT exist in the final assembly configuration. (While in development, the component can be packaged to facilitate analysis and clearance checks.)

13.5.3 The designer **shall** verify that the mechanism is in the correct state and/or location before being released.

13.5.4 A snapshot **shall** be created of the home position for the mechanism and set as the default location.

13.5.5 Assemblies and/or components **shall** NOT be checked into ICE Windchill while in a “Frozen” or “Suppressed” state due to missing placement references for creation of a baseline, for WGA, at release, and at other times as required at a minimum.

13.5.6 Components **shall** be correctly located with no unintended gaps or interferences.

### 13.6 Common Parts

13.6.1 Common parts **shall** be inserted from library folders within ICE Windchill.

13.6.2 If a Common part does not exist in ICE Windchill, refer to Desktop Instruction ED-CAD-DI-003, Library Components, for additional information.

### 13.7 Named Views and Cross-Section Datum Planes

13.7.1 Separate datum planes should be created for named and cross-section views used on the detail drawing.

13.7.2 If Datum Planes are created for named views, they **shall** be renamed to “**view\_viewname**”. For example, View A would be renamed “**view\_A**”.

13.7.3 If Datum Planes are created for cross-section views, they **shall** be renamed to “**sec\_sectionname**”. For example, Section A-A would be renamed “**sec\_A**”.

MSFC Technical Standard EV32		
Title: Computer-Aided Design (CAD) Standard	Document No.: MSFC-STD-3528	Revision: Revision E
	Effective Date: 10-JAN-2017	Page 64 of 98

### 13.8 Related Level Drawing Model (i.e., -REL1, etc.)

13.8.1 A related model is used only for the creation of an assembly drawing when the designer does not want to change or impact the engineering model structure. This technique allows the designer to add additional information that is required at the drawing level.

13.8.2 Refer to Desktop Instruction ED-CAD-DI-016, Related Companion Files, for additional information.

### 13.9 Shrinkwrap™ Files

13.9.1 The designer should create a Shrinkwrap file for each End Item.

13.9.2 All Shrinkwrap files **shall** have geometry to be referenced set to “None”.

13.9.3 Refer to Desktop Instruction ED-CAD-DI-010, Shrinkwrap Creation, for additional information.

### 13.10 Exploded Views

13.10.1 The designer may create an “Exploded View” to help make an assembly view more easily interpreted and also help facilitate manufacturing.

13.10.2 The exploded view **shall** be created at the assembly level only.

13.10.3 Drawing level exploded views **shall** NOT be created.

13.10.4 Refer to Desktop Instruction ED-CAD-DI-023, Exploded Views, for additional information.

### 13.11 Extraneous Entities

13.11.1 All extraneous entities should be deleted. An extraneous entity would be any entity that is not needed in the definition of the model geometry.

### 13.12 Large File Management

#### 13.12.1 Partial Assemblies

Partial assemblies are allowed when an intermediate assembly model would facilitate file management and drawing creation of large assemblies and **shall** use the companion file extension -PATL1, etc.



MSFC Technical Standard EV32		
Title: Computer-Aided Design (CAD) Standard	Document No.: MSFC-STD-3528	Revision: Revision E
	Effective Date: 10-JAN-2017	Page 65 of 98

### 13.13 Layouts

13.13.1 All models with parameters and/or relations driven by a layout **shall** NOT be undeclared to the layout prior to release.

### 13.14 Inseparable Assemblies

13.14.1 The following types of inseparable assemblies **shall** NOT be allowed to be detailed on one inseparable assembly drawing:

- a. Any assembly not included in 13.14.2.a.
- b. Weldments or bonded assemblies which do not have post-process machining, except as defined in 13.14.2 (b).
- c. Assemblies in which rivets are installed, except when rivets are used to attach nutplates as specified in 13.14.2.a.

13.14.2 The following types of inseparable assemblies **shall** be allowed, but not required, to be detailed on one inseparable assembly drawing:

NOTE: If piece parts are detailed in separate drawings, the assembly and piece parts utilize standard numbering per section 5.3.1.4.

- a. An assembly of vendor parts (inserts, pins, bushings, nutplates and their rivets) into a piece part. (The assembly will be -101 and the piece part will be -103. WT Parts will exist for both but a separate drawing does not exist for the -103. The vendor parts come from the library.)
- b. Weldments in which all parts are detailed at the assembly level and not as piece parts on the same drawing. (The CAD file for the drawing will be a -101 assembly. CAD parts will exist for the piece parts which will be numbered -103, -105, etc., but all dimensions are at the assembly level, not at the piece part level. Separate drawings do not exist for the -103, -105, etc. piece parts. WT Parts will exist for all. Post-process machining on the -101 weldment will be a “make from” on a new -001 drawing. Weldments in which the piece parts have their own drawings will be a -001 assembly.)
- c. Assemblies in which parts are bonded or welded together or have additive manufacturing prior to final machining. (The post process machining assembly will be the -101, and the assembly of the parts will be the -103. A separate drawing does not exist for the -103. WT Parts would exist for the -101 and -103. The parts that make up the -103 are detailed on their own drawings and follow standard numbering. The -101 would be a “make from” of the -103.)
- d. Flared piping and tubing. (The assembly will be -101 and the piping or tubing will be -103 with notes defining how to cut and assemble the pieces. A separate drawing does not exist for the -103 piece part. WT Parts will exist for the -101 and -103 plus any fittings that are part of the assembly.)

**CHECK THE MASTER LIST  
VERIFY THAT THIS IS THE CORRECT VERSION BEFORE USE**

<b>MSFC Technical Standard EV32</b>		
<b>Title: Computer-Aided Design (CAD) Standard</b>	<b>Document No.: MSFC-STD-3528 Effective Date: 10-JAN-2017</b>	<b>Revision: Revision E Page 66 of 98</b>

## **14. DRAWING REQUIREMENTS**

### **14.1 Drawing Standards**

14.1.1 Drawings **shall** be created in accordance with MSFC-STD-2806.

14.1.2 The standard font for text on new drawings **shall** be CG Triumvirate. Existing drawings may use MSFC02 or CG Triumvirate. A single font **shall** be used within the same drawing.

NOTE: The standard drawing font was changed from MSFC02 to CG Triumvirate with the release of revision B of the drawing templates. See Section 4.1.3.4 for additional information.

14.1.3 Axonometric views **shall** NOT be dimensioned.

### **14.2 Drawing Template and Format**

14.2.1 The designer **shall** use an approved drawing template from ICE Windchill. Refer to Paragraph 4.1.3.

14.2.2 The designer **shall** NOT create a drawing without a model attached, except for drawings of 2D geometry and some Kit Drawings (See Sections 14.3.12 and 14.3.13). If created without a model, then the formats will not properly populate.

14.2.3 The parametric fields of the drawing format **shall** NOT be overridden, except for tabulated drawings which should have the mass in a table and have SEE TAB in the weight block on the format.

14.2.4 The preferred drawing size is a “D” size drawing format. Other drawing format sizes are permissible for those designs that can be adequately defined on them.

14.2.5 Refer to Desktop Instruction ED-CAD-DI-008, Updating Drawing Formats, for additional information.

### **14.3 Drawing Content and Types of Drawings**

14.3.1 The drawing **shall** contain all the information necessary to complete the model definition and to inspect the part and/or assembly.

14.3.2 Parts **shall** be shown on the drawing with all the views necessary to define the part.

14.3.3 Drawing dimensions **shall** be associative to the 3D model including tabulated part tables and opposite parts.

14.3.4 Dimensions **shall** NOT be overridden within a drawing.

**CHECK THE MASTER LIST  
VERIFY THAT THIS IS THE CORRECT VERSION BEFORE USE**

<b>MSFC Technical Standard EV32</b>		
<b>Title: Computer-Aided Design (CAD) Standard</b>	<b>Document No.: MSFC-STD-3528</b>	<b>Revision: Revision E</b>
	<b>Effective Date: 10-JAN-2017</b>	<b>Page 67 of 98</b>

14.3.5 Dimensions that are called out in note form should be parametric with their associated model dimensions. See Appendix B for additional information.

14.3.6 The designer **shall** insert common symbols from the standard symbols library. Refer to Desktop Instruction ED-CAD-DI-007, Standard Symbols, for additional information.

14.3.7 Any free symbol **shall** be related to its respective view or object, so that the view and symbol move in unison.

14.3.8 Drawings of parts/assemblies **shall** be created as mono-detail (one part/assembly and one drawing) except when:

- Family Table driven/tabulated. See Section 12.1.2.5 for additional information.
- Opposite parts are detailed on the same drawing.
- Inseparable assemblies are defined on one drawing. See Section 13.14 for details of inseparable assemblies that can be detailed on one drawing.

14.3.9 SEE SEPARATE PARTS LIST **shall** be noted on the face of every drawing above the title block that requires an EPL. Refer to Paragraph 8.11 for Engineering Parts List.

#### 14.3.10 Drawings of Composites

14.3.10.1 A ply table **shall** be placed on the same sheet or next sheet of the representative view.

14.3.10.2 A ply rosette **shall** be placed for every composite drawing view to specify the 0, -45, 45, and 90 degrees orientation of the plies.

14.3.10.3 Section views that show ply layups may be shown at an enlarged scale, and are not required to be associative to the model. These views may be sketched in, and then turned into a drawing symbol, or sketched in as draft entities.

***Note:** If section views are sketched in, the designer **shall** group the draft entities together.*

14.3.10.4 When needed, zones for composites **shall** be noted on the drawing and NOT in the model.

#### 14.3.11 Drawings of 2D Geometry

14.3.11.1 Drawings of 2D geometry, such as schematics, drawing trees, layouts, and diagrams, may not have a model from which the drawing is generated.

<b>MSFC Technical Standard EV32</b>		
<b>Title: Computer-Aided Design (CAD) Standard</b>	<b>Document No.: MSFC-STD-3528</b>	<b>Revision: Revision E</b>
	<b>Effective Date: 10-JAN-2017</b>	<b>Page 68 of 98</b>

#### 14.3.12 Kit Drawings

A Kit Drawing is generated to define a group of items that normally do not by themselves constitute a complete functional assembly. A Kit Drawing may not have a model from which the drawing is generated. Acceptable uses of Kit Drawings are:

- Gathering parts to be used for modification of existing hardware;
- Gathering parts to be installed after delivery of a Configuration Item;
- Defining parts used in test configurations.

14.3.12.1 The Kit Drawing **shall** include a list of the entire kit contents, including part numbers, titles, and quantities. The list **shall** be on the face of the drawing in tabulated form using kit\_drawing\_table.tbl from the tables library.

14.3.12.2 The Kit Drawing **shall** have a general note indicating the Kit's use, e.g., "USE IN CONJUNCTION WITH (APPROPRIATE DRAWING OR PROCEDURE NUMBER)."

14.3.12.3 The Kit Drawing number should be referenced in the using assembly's drawing notes, and may also be listed on the using assembly's EPL as a reference.

14.3.12.4 Parts that are added to the assembly from the kit shall be assigned an assembly find number with a flag note which reads: "PART TO BE OBTAINED FROM KIT DRAWING 9XMXXXXX-XXX."

#### 14.3.13 Design Layout Drawings

14.3.13.1 A Design Layout drawing **shall** be drawn to scale with sufficient accuracy and completeness for its intended use.

14.3.13.2 When a Design Layout drawing needs to include parts or assemblies that are not assembled into the primary model, a –REL companion CAD file **shall** be used.

14.3.13.3 DESIGN LAYOUT **shall** be noted on the face of every drawing above the title block.

14.3.13.4 An ICE Windchill baseline **shall** be created upon completion of the Design Layout drawing and named in accordance with Section 5.

14.3.13.5 When a unique drawing number is not assigned, a –LAY companion CAD file **shall** be used.

#### 14.3.14 Envelope/ Vendor Item Control/ Source Control Drawings

14.3.14.1 A specification **shall** be prepared as a separate document if the requirements for the item cannot be readily captured in the drawing notes.

<b>MSFC Technical Standard EV32</b>		
<b>Title: Computer-Aided Design (CAD) Standard</b>	<b>Document No.: MSFC-STD-3528</b>	<b>Revision: Revision E</b>
	<b>Effective Date: 10-JAN-2017</b>	<b>Page 69 of 98</b>

14.3.14.2 The drawing and specification **shall** reference each other, so that both are required to fully define the item.

14.3.14.3 The same data **shall** NOT exist in both the drawing and the specification.

14.3.14.4 The drawing and specification **shall** be released simultaneously for initial release.

14.3.14.5 Refer to Section 12.24 for additional information.

#### 14.4 Drawing Notes

14.4.1 The designer **shall** use the “Insert Notes” toolkit to insert Common Notes on the drawing, except for 2D drawings and Kit drawings which **shall** have notes selected as needed.

14.4.2 The designer **shall** tailor Common Notes 3 through 8 as required for part drawings other than Altered Item, Envelope, Vendor Item Control, or Source Control drawings, and Common Notes 2 and 3 for assembly drawings using the information in the Standard Notes List. The designer **shall** tailor Common Note 1 for Altered Item drawings, and Common Notes 3 and 4 for Vendor Item Control and Source Control drawings.

14.4.3 The order of the Common Notes inserted using the toolkit **shall** NOT be changed.

14.4.4 Additional notes **shall** be added after the Common Notes.

14.4.5 The designer should select any additional note from the Standard Notes List if an appropriate note exists. Refer to Desktop Instruction ED-CAD-DI-004, Standard Drawing Notes, for information on adding notes to the Standard Notes List.

#### 14.5 Tabulated Drawing

14.5.1 The values that are table driven **shall** be shown fully parametric on the face of the drawing utilizing the repeat region functionality.

14.5.2 Refer to Desktop Instruction ED-CAD-DI-024, Tables and Tabulated Drawings, for additional information.

#### 14.6 Drawing Information from ICE Windchill

14.6.1 The drawing approvals captured in ICE Windchill during the release process **shall** be populated onto the face of the drawing by ICE Windchill before release.

14.6.2 A viewable in .pdf format of the released drawing **shall** be created automatically by ICE Windchill and associated with the drawing document in ICE Windchill.

<b>MSFC Technical Standard</b>		
<b>EV32</b>		
<b>Title: Computer-Aided Design (CAD) Standard</b>	<b>Document No.: MSFC-STD-3528</b>	<b>Revision: Revision E</b>
	<b>Effective Date: 10-JAN-2017</b>	<b>Page 70 of 98</b>

14.6.3 The drawing's primary model ICE Windchill file name, lifecycle state, and version **shall** be automatically displayed on the face of the drawing.

14.6.4 The drawing's ICE Windchill drawing object lifecycle state and version, including revision and iteration, **shall** be automatically displayed on the face of the drawing.

Legend: ® Creo Parametric and Windchill are registered trademarks of Parametric Technology Corporation or its subsidiaries in the U.S. and in other countries.

Fibersim is a registered trademark of Siemens Corporation in the U.S. and in other countries.

™ Creo View, Creo ModelCHECK, and Shrinkwrap are trademarks of Parametric Technology Corporation or its subsidiaries in the U.S. and in other countries.

<b>MSFC Technical Standard EV32</b>		
<b>Title: Computer-Aided Design (CAD) Standard</b>	<b>Document No.: MSFC-STD-3528 Effective Date: 10-JAN-2017</b>	<b>Revision: Revision E Page 71 of 98</b>

## **APPENDIX A**

### Initial Naming Convention Example

The initial CAD file name can have seven or eight distinct parts which define the Project Code, Concept ID, Element, Location, Subsystem/Component Function, Sequence Number, Part Number, and Companion File Type (when applicable):

- Project Code
  - 3 alpha characters assigned by CM.
  - For US, the Project Code is CLV
- Concept ID
  - 2 numeric characters
  - All files should be named 01 initially
  - 02, 03, etc., can be used for trades
- Element
  - 2 alpha characters defined within each project
  - Represents major divisions of a project
  - For US, the Elements are:
    - CE for Crew Exploration Vehicle
    - FS for First Stage
    - GS for Ground Support Equipment
    - US for Upper Stage
    - VE for Vehicle
- Location
  - Dash (-) followed by 2 alpha characters defined within each project
  - Represents the physical location of the hardware
  - More locations can be defined as needed
  - NH for Next Higher Level is used when the vehicle location is not confined to a single place, such as the top assembly of the US
  - For US, the Locations are:
    - AS for Aft Skirt
    - CB for Common Bulkhead
    - CS for Core Stage
    - CM for Crew Module
    - EN for Engine
    - FS for Forward Skirt
    - FR for Frustum
    - IU for Instrument Unit
    - IS for Interstage
    - LA for Launch Abort System
    - LH for LH2 Tank

**CHECK THE MASTER LIST  
VERIFY THAT THIS IS THE CORRECT VERSION BEFORE USE**

<b>MSFC Technical Standard EV32</b>		
<b>Title: Computer-Aided Design (CAD) Standard</b>	<b>Document No.: MSFC-STD-3528</b>	<b>Revision: Revision E</b>
	<b>Effective Date: 10-JAN-2017</b>	<b>Page 72 of 98</b>

- LO for LO2 Tank
- MN for Motor and Nozzle
- NH for Next Higher Assembly
- PF for Pathfinder
- SM for Service Module
- SA for Spacecraft Adapter
- ST for Systems Tunnel
- TC for Thrust Cone
- TR for Transporter
- Subsystem/Component Function
  - 2 alpha characters determined by the project
  - Represents the subsystem or function of the hardware
  - More subsystems/component functions can be defined as needed
  - IN for integration is used when there is not a single subsystem or function involved, such as an assembly of the avionics and pyrotechnics within the Interstage
  - For US, the Subsystem/Component Functions are:
    - AK for Access Kit
    - AV or Avionics (including cabling)
    - DS for Dry Structure
    - FX for Fixturing
    - HD for Handling
    - IN for Integration
    - MP for Main Propulsion System
    - MS for Mechanical System
    - PV for Purge and Vent
    - PY for Pyrotechnics
    - RC for Reaction/Roll Control System
    - SR for Servicing
    - SP for Solid Propulsion
    - TP for Thermal Protection System
    - TV for Thrust Vector Control
    - TS for Transportation
    - UM for Umbilical
    - WS for Wetted Structure (Tankage)
- Sequence Number
  - 4 numeric characters determined by the designer with the following restrictions:
    - Part and assembly files must have different model numbers in case the file extension is dropped
    - 9000 series will be used to specify the file type other than part, assembly, and drawing files

**CHECK THE MASTER LIST  
VERIFY THAT THIS IS THE CORRECT VERSION BEFORE USE**



<b>MSFC Technical Standard EV32</b>		
<b>Title: Computer-Aided Design (CAD) Standard</b>	<b>Document No.: MSFC-STD-3528</b>	<b>Revision: Revision E</b>
	<b>Effective Date: 10-JAN-2017</b>	<b>Page 73 of 98</b>

- For example: 9021 could be the sequence number for a skeleton file
      - 0000 should be used for the top assembly file within a subsystem and vehicle location
  - Part Number
    - Dash (-) followed by 3 numeric characters
    - Dash numbers will follow the convention defined in MSFC-STD-555 regarding odd dash numbers, even dash numbers, etc.
    - Most dash numbers will be -001
  - Companion File Type
    - “As-Designed” does not use a type extension
    - Refer to Paragraph 5.4 for additional information

Examples of file names:

CLV01CE-LAAV0001-001	CLV part or assembly for the CEV Launch Abort System Avionics
CLV01VE-NHIN0000	CLV top assembly drawing
CLV04GS-IUHD0057-002	CLV part or assembly for the Instrument Unit Handling GSE (mirror image of the -001 part)
CLV01US-CSWS0524-001-MOD1	CLV part or assembly for the Core Stage Liquid Hydrogen Tank “As-Installed” Panel

**CHECK THE MASTER LIST  
VERIFY THAT THIS IS THE CORRECT VERSION BEFORE USE**

<b>MSFC Technical Standard EV32</b>		
<b>Title: Computer-Aided Design (CAD) Standard</b>	<b>Document No.: MSFC-STD-3528 Effective Date: 10-JAN-2017</b>	<b>Revision: Revision E Page 74 of 98</b>

## **APPENDIX B**

### Additional Information For Reference Only

#### ***B1 Part Accuracy (4.1.6.3)***

The default value may need to be adjusted under the following conditions:

- a. Placing a very small feature on a very large part
- b. Intersecting (through merge or cutout) two parts of very different size.

Increasing the part accuracy can cause longer regeneration times and larger file sizes. The part will have upper and lower bounds on what the accuracy can be. If an accuracy is too tight, a value should be chosen between the given bounds.

After changing the accuracy, the model must be regenerated. Because the part is now being calculated at a higher accuracy, features may now fail, causing the designer to go into resolve mode.

The accuracy setting controls the computational accuracy of geometry calculations. The accuracy controls the shortest distance between two points that can be seen as two separate points. Creo Parametric has two options for accuracy

- Relative – total accuracy is dependent upon the overall size of the model
- Absolute – directly sets a value regardless of the overall part size.

#### ***B2 ModelCHECK (4.2.5)***

ModelCHECK:

- Analyzes parts, drawings, and assemblies.
- Verifies compliance with standards and proper Creo Parametric modeling techniques and immediately flags modeling violations.
- Presents the results of the analysis and recommends improvements in the form of a dynamic HTML report. The ModelCHECK report appears in the browser embedded in Creo Parametric.
- Promotes the use of standard design practices to improve the effectiveness of downstream users and design reuse.

ModelCHECK can be configured to identify items in violation of the design standards as either Errors or Warnings. In general, errors are those items that the user must resolve in order to submit the model for approval or release. Warnings are items that the user should resolve prior to approval or release. Even though any items identified as warnings can be considered optional (not required to be fixed), these items do represent MSFC recommended best modeling practices and users should make every attempt to resolve any warnings prior to release.

**CHECK THE MASTER LIST  
VERIFY THAT THIS IS THE CORRECT VERSION BEFORE USE**

MSFC Technical Standard EV32		
Title: Computer-Aided Design (CAD) Standard	Document No.: MSFC-STD-3528	Revision: Revision E
	Effective Date: 10-JAN-2017	Page 75 of 98

### B3 Deleted

### B4 Layers (6.1)

To determine what layer/layers an item is on, Right Mouse Button (RMB) click on the feature and choose Info > Feature. This will bring up a browser window that will show layer the feature is on.

Items can be moved from one layer to another by using the cut and paste option. This is accomplished by expanding the layer in the layer tree and right mouse button clicking on the item and choosing Cut Item. Then choose the correct layer, RMB click, and choose Paste Item. If an item is on multiple layers, choose the Remove Item option.

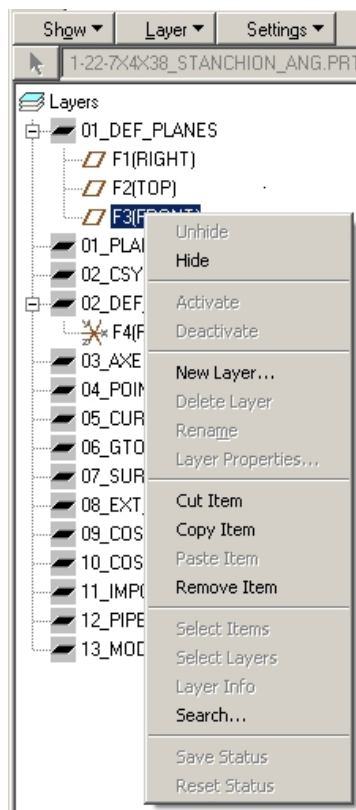

New layers can be created by RMB clicking on the layer tree and choose New Layer. The layer can be named and items can be selected from the model tree. Rules can also be set up using the rules option.

### B5 Parameters (6.5)

Parameters are useful for providing information about an object. Creo Parametric allows parameters to be assigned to features, drawings, and part and assembly models.

**CHECK THE MASTER LIST  
VERIFY THAT THIS IS THE CORRECT VERSION BEFORE USE**

MSFC Technical Standard EV32		
Title: Computer-Aided Design (CAD) Standard	Document No.: MSFC-STD-3528	Revision: Revision E
	Effective Date: 10-JAN-2017	Page 76 of 98

Parameters are typically used to control information, such as drawing titles, part numbers, and next assembly information.

**B6**    **Common Parts Library (7.3.4)**

By selecting the part number from the Master List sheet, the designer can see the specific part numbers that are available in the library. The information on size, material, etc. is for reference only and the designer must refer to the part specification to confirm the proper part is chosen. The part number, CAGE code (if applicable), unit weight, and description given in the list will be automatically populated into the EPL.

**B7**    **Symbol Library (7.4.3)**

These symbols can be accessed from the drafting application by choosing the ~~insert~~ custom symbol command and choosing browse.

**B8**    **Product Structure (8.6.12)**

A product structure is a hierarchical representation of all assemblies and component parts necessary to assemble an end item. A product structure can be expanded (that is, expand each sub assembly to see its child parts) until the lowest level component parts are shown. A BOM report can be generated from the expanded product structure.

**B9**    **Deleted.**

**B10**    **ICE Windchill Baselines (8.9.4)**

In ICE Windchill, an “ICE Windchill baseline” is a managed object that provides a mechanism for capturing a set of information at a particular point in time – an ICE Windchill baseline is a “snapshot” of a precise list of PLM objects, specifying both version and iteration. The list may include Documents, CAD Documents, and WT Parts. This list is used to document specific sets of data that have either been uploaded, delivered or are at a significant design milestone.

ICE Windchill Baselines are not formally CM-controlled, but are managed in ICE Windchill. ICE Windchill baselines function as follows:

- Once an ICE Windchill baseline is created, parts and documents can be added/removed from it.
- An ICE Windchill baseline can contain any number of parts and documents, and a part or document can be in any number of baselines.
- An ICE Windchill baseline can contain only one version of any unique part or document

**CHECK THE MASTER LIST  
VERIFY THAT THIS IS THE CORRECT VERSION BEFORE USE**

<b>MSFC Technical Standard</b>		
<b>EV32</b>		
<b>Title: Computer-Aided Design (CAD) Standard</b>	<b>Document No.: MSFC-STD-3528</b>	<b>Revision: Revision E</b>
	<b>Effective Date: 10-JAN-2017</b>	<b>Page 77 of 98</b>

***B11 Configurations (8.10)***

A configuration is the specification rule that allows the system to retrieve particular versions and iterations of the ICE Windchill objects from the database. The retrieval typically starts by selecting a specific version and iteration of an object from the system and then gathering up related information based upon the specified configuration. This allows the system to provide only the files that match the configuration specification.

The system comes out of the box with two configurations; Latest and As-Stored. Latest is an imprecise configuration that retrieves the latest version and iteration of an ICE Windchill object that has been checked in. As-Stored is a precise configuration that selects precisely the versions and iterations of any related information based upon the “Latest” definition when the object was stored (checked in). Unless manually changed Latest is the default configuration used for retrieving information (except automatic for creation of viewables which uses As-Stored).

ICE Windchill Baselines and Lifecycle States can also be used to specify the files to retrieve from the database. The related information can be based upon either the Model Structure or the Product Structure.

***B12 Deleted.***

***B13 Deleted.***

***B14 Viewables (8.17.3)***

A Viewable is a snapshot of an object’s primary content in a format suitable for viewing. The format of the viewable is typically a neutral format. For 3D data this format typically requires significantly less computer resources in order view the data than that needed for the full CAD editing tool. The format for 3D data is in Creo View™ format; the 2D CAD Data is published as pdf format.

***B15 Deleted.***

***B16 Round and Chamfers (12.13.6)***

Use the CTRL key to make one round set after creating rounds using the “Intent edges” first, and then by the “Multi” selection tool.

***B17 Drawing Content (14.3.5)***

The following describes how to make dimensions that are called out in note form parametric with their associated model dimensions:

<b>MSFC Technical Standard EV32</b>		
<b>Title: Computer-Aided Design (CAD) Standard</b>	<b>Document No.: MSFC-STD-3528</b>	<b>Revision: Revision E</b>
	<b>Effective Date: 10-JAN-2017</b>	<b>Page 78 of 98</b>

To let a value drive a note, the dimension symbol name must be determined using the model. All values used to create a model have dimension symbol names. An example is that a length dimension might have the name d67.

1) One way of determining the symbol name is to find the feature in the model tree, RMB click on it, and select Info > Feature. This will bring up a browser window. Scroll down to the Feature's Dimensions section and see the Dimension ID, as shown below:

FEATURE'S DIMENSIONS:	
Dimension ID	Dimension Value
<a href="#">d66</a>	.250 Dia
<a href="#">d67</a>	.500
<a href="#">d68</a>	.500
<a href="#">d69</a>	.500

If several dimensions have the same value, it can be difficult to determine the correct ID number.

2) Another way to determine the symbol name is to find the feature in the model tree, RMB click on it, and select Edit. This brings up the values. Select Info, Switch Dimensions and this will change the values to the symbol name, as shown below.

<b>MSFC Technical Standard EV32</b>		
<b>Title: Computer-Aided Design (CAD) Standard</b>	<b>Document No.: MSFC-STD-3528</b>	<b>Revision: Revision E</b>
	<b>Effective Date: 10-JAN-2017</b>	<b>Page 79 of 98</b>

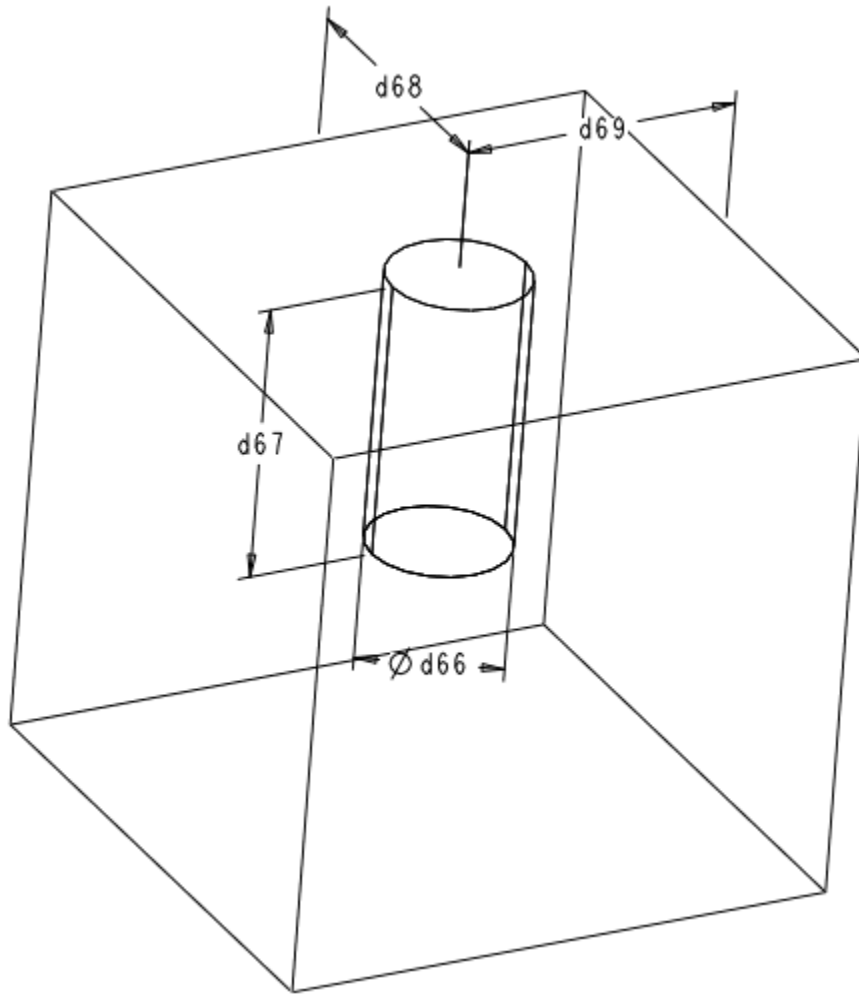

For this example, d66 will be used in a note for the diameter, and d67 will be used for depth. When typing the note, replace the value with a text string of &d## as shown in the following figure:

**CHECK THE MASTER LIST  
VERIFY THAT THIS IS THE CORRECT VERSION BEFORE USE**

<b>MSFC Technical Standard EV32</b>		
<b>Title: Computer-Aided Design (CAD) Standard</b>	<b>Document No.: MSFC-STD-3528</b>	<b>Revision: Revision E</b>
	<b>Effective Date: 10-JAN-2017</b>	<b>Page 80 of 98</b>

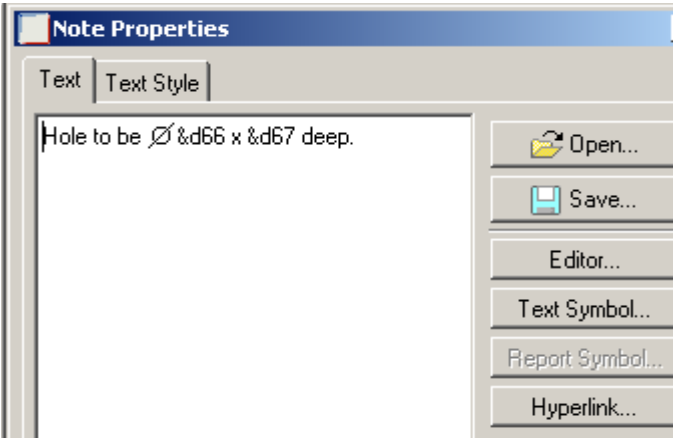

This text string will result in the following note:

Hole to be Ø .250 x .500 deep.



<b>MSFC Technical Standard EV32</b>		
<b>Title: Computer-Aided Design (CAD) Standard</b>	<b>Document No.: MSFC-STD-3528</b>	<b>Revision: Revision E</b>
	<b>Effective Date: 10-JAN-2017</b>	<b>Page 81 of 98</b>

**APPENDIX C**

(Deleted.)

<b>MSFC Technical Standard EV32</b>		
<b>Title: Computer-Aided Design (CAD) Standard</b>	<b>Document No.: MSFC-STD-3528</b>	<b>Revision: Revision E</b>
	<b>Effective Date: 10-JAN-2017</b>	<b>Page 82 of 98</b>

## **APPENDIX D**

### Designer's Checklist

Design Package Description \_\_\_\_\_

File Name \_\_\_\_\_ Rev \_\_\_\_\_

Designer \_\_\_\_\_ Checker \_\_\_\_\_

Date \_\_\_\_\_ Applicable Checklist Section: C    A    D    W  
(Circle all that apply: C for Component, A for Assembly, D for Drawing, W for WT Part)

#### ***Component Modeling Requirements***

***(Refer to MSFC-STD-3528)***

Item	Description	Designer	Peer	Check
C-1	<p><i>Models are created in English units. (Paragraph 4.1.1.2)</i></p> <p><u><i>Application Notes:</i></u>  <i>Units for English files should be set to proe_def (inch lbm second).</i></p> <p><i>This can be checked in Creo Parametric using following function:</i>  <i>File&gt;Prepare&gt;Model Properties –</i>  <i>On the Model Properties dialogue box, select:</i>  <i>Units&gt;change&gt;info</i></p> <p><i>This does not apply to metric vendor items and standard parts, which would be modeled using MKS. (Paragraph 4.1.1.4)</i></p>			
C-2	<p><i>Parts are modeled at the geometric mean of the tolerance band, except for drilled/reamed holes. (Paragraph 4.1.4.3, 12.12.4)</i></p> <p><u><i>Application Notes:</i></u>  <i>Tolerance information is provided on the drawing using either shown or created dimensions.</i></p>			
C-3	<p><i>Relative accuracy is not used. (Paragraph 4.1.6.2)</i></p>			

**CHECK THE MASTER LIST  
VERIFY THAT THIS IS THE CORRECT VERSION BEFORE USE**

<b>MSFC Technical Standard EV32</b>		
<b>Title: Computer-Aided Design (CAD) Standard</b>	<b>Document No.: MSFC-STD-3528</b>	<b>Revision: Revision E</b>
	<b>Effective Date: 10-JAN-2017</b>	<b>Page 83 of 98</b>

Item	Description	Designer	Peer	Check
C-4	<p><i>Errors found by ModelCHECK have been resolved. Warnings have been evaluated and resolved where possible. (Paragraph 4.2.4)</i></p> <p><u>Application Notes:</u> <i>Refer to EC-CAD-DI-026 for acceptable occurrences of modeling techniques that ModelCHECK lists as an error.</i></p>			
C-5	<p><i>Name and numbering convention for WT Parts, CAD Documents and CAD files are used within ICE Windchill. (Section 5)</i></p> <p><u>Application Notes:</u> <i>File names are to be accordance with the Section 5 file name convention.</i></p>			
C-6	<p><i>Descriptive names for all CAD Documents and WT Parts provide appropriate detail and uses standard conventions for naming of subsystem components. (Section 5)</i></p> <p><i>The CAD Document and WT Part names match with standard practice for drawing title. (Section 5)</i></p> <p><u>Application Notes:</u> <i>The ICE Windchill CAD Document Name and ICE Windchill WT Part name will be the same as the Creo Parametric file common name.</i></p>			

**CHECK THE MASTER LIST  
VERIFY THAT THIS IS THE CORRECT VERSION BEFORE USE**

<b>MSFC Technical Standard EV32</b>		
<b>Title: Computer-Aided Design (CAD) Standard</b>	<b>Document No.: MSFC-STD-3528</b>	<b>Revision: Revision E</b>
	<b>Effective Date: 10-JAN-2017</b>	<b>Page 84 of 98</b>

Item	Description	Designer	Peer	Check
C-7	<p><i>Solid geometry features (holes, fillets, cutouts, etc) are modeled in the “As-Designed” condition for detail parts, and in the “As-Installed” condition for assembled parts. (Paragraphs 5.4.2, 6.7.2.1, 8.8.1, 12.20.1)</i></p> <p><u>Application Notes:</u> <i>Applies to parts which are modified at assembly. Use a companion -MOD file when then “As-Installed” condition is different from the “As-Designed” condition.</i></p> <p><i>Example: Common bulkhead core would have multiple models (one for initial machined detail and another for how it appears “As-Installed” in the assembly).</i></p>			N/A
C-8	<i>Default layers are present, properly utilized, and have not been renamed. All non-solid layers are hidden. Items reside on only one layer. (Paragraph 6.1)</i>			
C-9	<i>Units have been assigned for parameters controlling solid geometry. (Paragraph 6.5.1)</i>			
C-10	<p><i>All parameters are correctly populated within the Creo Parametric model (Paragraph 6.5.4.1)</i></p> <p><u>Application Notes:</u> <i>Alternate mass properties may be entered instead of calculated for vendor part models.</i></p> <p><i>Material assignment should be from the material library. New materials should be entered into this library when needed in accordance with ED-CAD-DI-019.</i></p>			

**CHECK THE MASTER LIST  
VERIFY THAT THIS IS THE CORRECT VERSION BEFORE USE**

<b>MSFC Technical Standard EV32</b>		
<b>Title: Computer-Aided Design (CAD) Standard</b>	<b>Document No.: MSFC-STD-3528</b>	<b>Revision: Revision E</b>
	<b>Effective Date: 10-JAN-2017</b>	<b>Page 85 of 98</b>

Item	Description	Designer	Peer	Check
C-11	<i>Units have been assigned for all constant values used in relations. (Paragraph 6.6.2)</i>			
C-12	<i>Standard simplified representations exist within the model, are up-to-date, and meet standard definition for the representation. (Paragraph 6.7.2)</i> - <i>MASTER remains the default rep</i>			
C-13	<i>One part configuration model per file, except where required by business practices or by Creo Parametric limitations. (Paragraph 8.8.1.3, 14.3.8)</i>  <i><u>Application Notes:</u> Do not have multiple details in one model (i.e. as-machined, formed and flat conditions). The MASTER rep is the condition of the model that will be manufactured. Family Tables may be used for “As-Installed” part modifications, tabulated drawings, and library parts.</i>			
C-14	<i>Internal and external threads are modeled as follows: (Paragraph 10.12)</i>  <i>Internal Thread: Hole Dia. Is nominal tap drill size (sizes from Creo Parametric Hole Table are acceptable)</i> <i>External Thread: Shaft Dia. Is nominal major dia.</i>			
C-15	<i>3D Solid Model contains complete feature history. This does not apply to vendor supplied models. (Paragraph 12.1.2.1)</i>  <i><u>Application Notes:</u> Features as modeled should remain in the model tree.</i>  <i>Do not export to a neutral format and re-import to clean up features or dependencies.</i>			

**CHECK THE MASTER LIST  
VERIFY THAT THIS IS THE CORRECT VERSION BEFORE USE**

<b>MSFC Technical Standard EV32</b>		
<b>Title: Computer-Aided Design (CAD) Standard</b>	<b>Document No.: MSFC-STD-3528</b>	<b>Revision: Revision E</b>
	<b>Effective Date: 10-JAN-2017</b>	<b>Page 86 of 98</b>

Item	Description	Designer	Peer	Check
C-16	<i>Inheritance features have been set to “Independent” and copy geom. feature have been set to “Independent” prior to release. (Paragraph 12.1.2.1, 12.7.4)</i>			
C-17	<p><i>Opposite parts reside in their own part file, but have associated master definition only in the first part file. (Paragraph 12.1.2.3)</i></p> <p><u><i>Application Notes:</i></u>  <i>Dependent mirror (opposite) model must be an exact duplicate of the as-shown model. Drawing may show as-shown and opposite.</i></p> <p><i>If an opposite model requires a change such that it is no longer an exact mirror of the as-shown model then the opposite part becomes unique at that time. A new part should be created and used for the changed model with a different drawing number and part number. The as-shown model may be used to help create the new mirror part (save-as and mirror feature in part file). The new part can then be modified as needed.</i></p> <p><i>Typical operation for revision (both as-shown and opposite must be revised together) would be to make modifications in the as-shown model and create a (new) opposite model based upon the revised as-shown model. This new model would then be uploaded to ICE Windchill as the new revision of the opposite model.</i></p>			
C-18	<p><i>Models are created with all features (such as fillets, chamfers and holes) except where covered by Standard Notes. (Paragraph 12.1.2.6)</i></p> <p><u><i>Application Notes:</i></u>  <i>All features required to represent the part should be present. This part file will drive the manufacturing and therefore must be geometrically accurate.</i></p>			

**CHECK THE MASTER LIST  
VERIFY THAT THIS IS THE CORRECT VERSION BEFORE USE**

<b>MSFC Technical Standard EV32</b>		
<b>Title: Computer-Aided Design (CAD) Standard</b>	<b>Document No.: MSFC-STD-3528</b> <b>Effective Date: 10-JAN-2017</b>	<b>Revision: Revision E</b> <b>Page 87 of 98</b>

Item	Description	Designer	Peer	Check
C-19	<p><i>Model has no suppressed or frozen features. (Paragraph 12.2.2)</i></p> <p><u>Application Notes:</u> <i>Generic models for family table instances are an exception to this rule.</i></p> <p><i>Does not apply to features within an inheritance feature.</i></p>			
C-20	<i>Deleted.</i>			N/A
C-21	<p><i>Created Datum Planes used for named views have been renamed to “view_viewname”. (Paragraph 12.10.2)</i></p> <p><u>Application Notes:</u> <i>View A would be renamed “view_A”.</i></p>			N/A
C-22	<p><i>Created Datum Planes used for cross-section views have been renamed to “sec_sectionname”. (Paragraph 12.10.3)</i></p> <p><u>Application Notes:</u> <i>Section A-A would be renamed “sec_A”.</i></p>			N/A
C-23	<p><i>Drilled holes, chamfers, and fillets should be created using the hole, chamfer and round tools. (Paragraphs 12.12.5, 12.13.4)</i></p> <p><u>Application Notes:</u> <i>Do not include these features within a sketch except where required by business practices or Creo Parametric limitations.</i></p> <p><i>Use a pattern of holes instead of an extrude feature with multiple sketched holes.</i></p> <p><i>Extrusion of a circular sketch or revolution of a sketch to produce a hole is allowed based upon design intent and Creo Parametric limitations.</i></p>			N/A

**CHECK THE MASTER LIST  
VERIFY THAT THIS IS THE CORRECT VERSION BEFORE USE**

MSFC Technical Standard EV32		
Title: Computer-Aided Design (CAD) Standard	Document No.: MSFC-STD-3528	Revision: Revision E
	Effective Date: 10-JAN-2017	Page 88 of 98

Item	Description	Designer	Peer	Check
C-24	<i>Model conforms to all applicable ICDs prior to initial release.</i>  <u>Application Note:</u> <i>Part model geometry should conform to any applicable interface skeletons.</i>			
C-25	<i>Rounds and chamfers do not have children. (Paragraph 12.13.5)</i>  <u>Application Note:</u> <i>Acceptable exceptions are noted in ED-CAD-DI-026, Verifying 3-Dimensional CAD Models.</i>			
C-26	<i>Ply boundary curves or surfaces exist for each ply and are projected onto the correct layup surface. (Paragraph 12.22.2)</i>			
C-27	<i>Ply boundary curves or surfaces are named PLYxxxx, where xxxx represents a four digit number. (Paragraph 12.22.3)</i>			
C-28	<i>Each ply boundary curve or surface is on a separate user-defined layer that is named according to the ply name, unless ply boundaries are exactly the same. (Paragraph 12.22.4)</i>			
C-29	<i>The tooling surface definition is extended at least six inches beyond the edges of the part, is placed on a user-defined layer named 99_TOOLING_SURFACE, and is hidden. (Paragraph 12.22.5)</i>			
C-30	<i>All external references have been set to "Independent" prior to release. (Paragraph 9.1.2.2)</i>			

**CHECK THE MASTER LIST  
VERIFY THAT THIS IS THE CORRECT VERSION BEFORE USE**



<b>MSFC Technical Standard EV32</b>		
<b>Title: Computer-Aided Design (CAD) Standard</b>	<b>Document No.: MSFC-STD-3528</b>	<b>Revision: Revision E</b>
	<b>Effective Date: 10-JAN-2017</b>	<b>Page 89 of 98</b>

**Assembly Requirements**

**(Refer to MSFC-STD-3528)**

Item	Description	Designer	Peer	Check
A-1	<p><i>Errors found by ModelCHECK have been resolved. Warnings have been evaluated and resolved where possible. (Paragraph 4.2.4)</i></p> <p><u>Application Notes:</u> <i>Refer to EC-CAD-DI-026 for acceptable occurrences of modeling techniques that ModelCHECK lists as an error.</i></p>			
A-2	<p><i>Descriptive names for all CAD Documents and WT Parts provide appropriate detail and uses standard conventions for naming of subsystem components. (Section 5)</i></p> <p><i>The CAD Document and WT Part names should match with standard practice for drawing title. (Section 5)</i></p> <p><u>Application Notes:</u> <i>The ICE Windchill CAD Document Name and ICE Windchill WT Part name will be the same as the Creo Parametric file common name.</i></p>			
A-3	<p><i>Assemblies do not incorporate any features that modify part geometry (match drill, etc.). Parts to be modified at assembly are shown in a modified (“As-Installed”) state contained in separate companion part files controlled within ICE Windchill. (Paragraph 5.4, 13.4)</i></p> <p><u>Application Notes:</u> <i>This means that a part would be required for the “As-Designed” condition and the “As-Installed” condition.</i></p> <p><i>“As-Installed” is a –MOD companion file.</i></p>			
A-4	<p><i>Default layers are present, properly utilized, and have not been renamed. Components do not reside on layers. All layers are hidden. Items reside on only one layer. (Paragraph 6.1)</i></p>			

**CHECK THE MASTER LIST  
VERIFY THAT THIS IS THE CORRECT VERSION BEFORE USE**

<b>MSFC Technical Standard EV32</b>		
<b>Title: Computer-Aided Design (CAD) Standard</b>	<b>Document No.: MSFC-STD-3528</b>	<b>Revision: Revision E</b>
	<b>Effective Date: 10-JAN-2017</b>	<b>Page 90 of 98</b>

Item	Description	Designer	Peer	Check
A-5	<p><i>All parameters are correctly populated within the Creo Parametric model and the designated attributes in the ICE Windchill CAD Document from the ICE Windchill Details page contain matching values. (Paragraph 6.5.4.1)</i></p> <p><u>Application Notes:</u> <i>Alternate mass properties may be entered instead of calculated for vendor part models.</i></p>			
A-6	<p><i>Standard simplified representations exist as needed within the assembly, are up-to-date, and meet standard definition for the representation. (Paragraph 6.7.3)</i></p> <ul style="list-style-type: none"> <li>- MAIN</li> <li>- EMPTY</li> <li>- MAIN_NO_FASTENERS</li> <li>- SIMPLE</li> <li>- OML</li> </ul>			
A-7	<p><i>No bulk items exist in the assembly, except those allowed in Paragraph 6.8. (Paragraph 6.8)</i></p>			
A-8	<p><i>Installed configurations of detail parts (flexible cable, ducting, etc.) are contained in separate part files controlled within ICE Windchill. (Paragraph 12.20)</i></p> <p><u>Application Notes:</u> <i>Cables, Piping, Ducting etc. would be created in assembly in the “As-Installed” condition and a part would be created for the applicable cable, pipe or duct.</i></p>			
A-9	<p><i>There are no assembly level cuts. (Paragraph 13.4.1)</i></p> <p><u>Application Notes:</u> <i>-MOD files are used at the part level to represent any modifications required at the assembly level.</i></p>			

**CHECK THE MASTER LIST  
VERIFY THAT THIS IS THE CORRECT VERSION BEFORE USE**

<b>MSFC Technical Standard EV32</b>		
<b>Title: Computer-Aided Design (CAD) Standard</b>	<b>Document No.: MSFC-STD-3528</b>	<b>Revision: Revision E</b>
	<b>Effective Date: 10-JAN-2017</b>	<b>Page 91 of 98</b>

Item	Description	Designer	Peer	Check
A-10	<p><i>Assembly components are fully constrained unless required for mechanisms. (Paragraph 13.5)</i></p> <p><u>Application Notes:</u> <i>Components used in <b>mechanisms</b> may be packaged depending on their function. A snapshot of the home position is set as the default location.</i></p>			
A-11	<p><i>Model has no suppressed or frozen features or components due to missing placement references. (Paragraph 13.5.5)</i></p>			
A-12	<p><i>Components are correctly located with no unintended gaps or interferences with other parts. (Paragraph 13.5.6)</i></p> <p><u>Application Notes:</u> <i>This requirement would not be applicable to components that by design should interfere. Press fit parts and threaded parts are an example of this condition.</i></p>			
A-13	<p><i>Common parts are inserted only from ICE Windchill Common part libraries. (Paragraph 13.6)</i></p> <p><u>Application Notes:</u> <i>Use ED-CAD-DI-003 for commercial vendor supplied and MIL-SPEC hardware on ICE Windchill.</i></p> <p><i>Applies to standard hardware not under design control by MSFC.</i></p>			
A-14	<p><i>Deleted.</i></p>			
A-15	<p><i>Created Datum Planes used for named views have been renamed to “view_viewname”. (Paragraph 13.7..2)</i></p> <p><u>Application Notes:</u> <i>View A would be renamed “view_A”.</i></p>			N/A

**CHECK THE MASTER LIST  
VERIFY THAT THIS IS THE CORRECT VERSION BEFORE USE**

<b>MSFC Technical Standard EV32</b>		
<b>Title: Computer-Aided Design (CAD) Standard</b>	<b>Document No.: MSFC-STD-3528</b>	<b>Revision: Revision E</b>
	<b>Effective Date: 10-JAN-2017</b>	<b>Page 92 of 98</b>

Item	Description	Designer	Peer	Check
A-16	<p><i>Created Datum Planes used for cross-section views have been renamed to “sec_sectionname”. (Paragraph 13.7.3)</i></p> <p><u>Application Notes:</u> <i>Section A-A would be renamed “sec_A”.</i></p>			N/A
A-17	<p><i>All Shrinkwrap files have the geometry referenced set to “None”. (Paragraph 13.9.2)</i></p>			N/A
A-18	<p><i>Released assemblies contain only components that are released or otherwise “controlled”.</i></p> <p><u>Application Notes:</u> <i>Also applicable to standard library parts used in assemblies.</i></p> <p><i>Controlled means that it is under CM control on ICE Windchill (i.e. has a lifecycle status of released or vendor released).</i></p>			
A-19	<p><i>All external references have been set to “Independent” prior to release. (Paragraph 9.1.2.2)</i></p>			

**CHECK THE MASTER LIST  
VERIFY THAT THIS IS THE CORRECT VERSION BEFORE USE**

<b>MSFC Technical Standard EV32</b>		
<b>Title: Computer-Aided Design (CAD) Standard</b>	<b>Document No.: MSFC-STD-3528</b>	<b>Revision: Revision E</b>
	<b>Effective Date: 10-JAN-2017</b>	<b>Page 93 of 98</b>

**Drawing Requirements**

**(Refer to MSFC-STD-3528)**

Item	Description	Designer	Peer	Check
D-1	<i>Drawing tolerances are all equal-bilateral, with the possible exception of drilled/reamed holes. (Paragraph 4.1.4.3, 4.1.4.4, 12.12.4)</i>			
D-2	<i>Errors found by ModelCHECK have been resolved. Warnings have been evaluated and resolved where possible. (Paragraph 4.2.4)</i>  <i><u>Application Notes:</u> Refer to EC-CAD-DI-026 for acceptable occurrences of modeling techniques that ModelCHECK lists as an error.</i>			
D-3	<i>The CAD Document and WT Part names match with standard practice for drawing title. (Section 5)</i>  <i><u>Application Notes:</u> The ICE Windchill CAD Document Name and ICE Windchill WT Part name will be the same as the-Creo Parametric file common name.</i>			
D-4	<i>All drawings are controlled by layers at the drawing level, not at the model level. Layers of a drawing have their status saved such that the appearance of the drawing is retained. (Paragraph 6.1.1.4, 6.1.1.5)</i>			
D-5	<i>The material note for homogeneous solid body part drawings matches the material assigned to the model. (Paragraph 6.3.1)</i>			
D-6	<i>All parameters are correctly populated within the drawing. (Paragraph 6.5.4.2)</i>  <i><u>Application Notes:</u> Configuration Control parameters will be populated by CM and are not checked prior to release.</i>			

**CHECK THE MASTER LIST  
VERIFY THAT THIS IS THE CORRECT VERSION BEFORE USE**

<b>MSFC Technical Standard EV32</b>		
<b>Title: Computer-Aided Design (CAD) Standard</b>	<b>Document No.: MSFC-STD-3528</b>	<b>Revision: Revision E</b>
	<b>Effective Date: 10-JAN-2017</b>	<b>Page 94 of 98</b>

Item	Description	Designer	Peer	Check
D-7	<p><i>The first notes for part and assembly drawings are the Common Notes placed using the toolkit. Not Applicable has been selected for any of the notes that do not apply. (Paragraph 7.2)</i></p> <p><u>Application Notes:</u> <i>The note will read Reserved.</i></p>			
D-8	<p><i>Standard symbols come from the approved standard symbols library. (Paragraph 7.4)</i></p>			N/A
D-9	<p><i>The Find Numbers on the drawing match the Find Numbers on the EPL. (Paragraph 8.11.2, 8.11.3)</i></p>			
D-10	<p><i>Drawings are created in accordance with MSFC-STD-2806. (Paragraph 14.1.1)</i></p>			
D-11	<p><i>Drawing dimensions are associated to 3D model including tabulated part tables. Dimensions are not overridden locally within the drawing. (Paragraph 14.3.3, 14.3.4, 14.3.5)</i></p> <p><u>Application Notes:</u> <i>Both shown dimension and created (driven) dimensions in the drawing are associative to the 3D model.</i></p> <p><i>Dimensions that are called out in note form are parametric with their associated model dimensions if possible.</i></p>			
D-12	<p><i>Drawing notes come from the approved standard notes library when appropriate. (Paragraph 14.4)</i></p>			
D-13	<p><i>Drawing identifies its ICE Windchill drawing object's lifecycle state and version on the face of the drawing. Drawing identifies its primary model ICE Windchill file name, lifecycle state, and version on the face of the drawing. (Paragraph 14.6)</i></p>			
D-14	<p><i>A pdf version of the drawing as-submitted for release is created and associated with the drawing document on ICE Windchill. (Paragraph 14.6.2)</i></p>			

**CHECK THE MASTER LIST  
VERIFY THAT THIS IS THE CORRECT VERSION BEFORE USE**

<b>MSFC Technical Standard EV32</b>		
<b>Title: Computer-Aided Design (CAD) Standard</b>	<b>Document No.: MSFC-STD-3528</b>	<b>Revision: Revision E</b>
	<b>Effective Date: 10-JAN-2017</b>	<b>Page 95 of 98</b>

Item	Description	Designer	Peer	Check
D-15	<p><i>Project approved drawing format has been used.</i></p> <p><i>Application Notes:</i>  MSFC_DWG_B_FORMAT_*REV-.FRM  MSFC_DWG_C_FORMAT_*REV-.FRM  MSFC_DWG_D_FORMAT_*REV-.FRM  MSFC_DWG_E_FORMAT_*REV-.FRM  MSFC_DWG_J_FORMAT_*REV-.FRM</p> <p><i>*Latest Revision.</i></p>			
D-16	<p><i>Materials have been assigned and mass properties calculated for any companion file generated from an inheritance.</i></p> <p><i>Application Notes:</i>  This is not necessary if the companion file is generated from a family table.</p>			
D-17	<i>A ply table is on the same sheet or next sheet of the representative view of the drawing. (Paragraph 14.3.11)</i>			
D-18	<i>A ply rosette exists for every view to specify the 0, -45, 45, and 90 degrees orientation of the plies. (Paragraph 14.3.11)</i>			
D-19	<i>Zones for composites are noted on the drawing when needed. (Paragraph 14.3.11)</i>			

**CHECK THE MASTER LIST  
VERIFY THAT THIS IS THE CORRECT VERSION BEFORE USE**

<b>MSFC Technical Standard EV32</b>		
<b>Title: Computer-Aided Design (CAD) Standard</b>	<b>Document No.: MSFC-STD-3528</b> <b>Effective Date: 10-JAN-2017</b>	<b>Revision: Revision E</b> <b>Page 96 of 98</b>

***WT Part Requirements (Refer to MSFC-STD-3528)***

Item	Description	Designer	Peer	Check
W-1	<i>EPL report is correctly generated with the correct values from the Product Structure using the Release Baseline. (Paragraph 8.6.3, 8.6.9, 8.11.1)</i>			
W-2	<i>The primary CAD Document for the WT Part represents the “As-Designed” part model. (Paragraph 8.8.1.1)</i>			
W-3	<i>A WT Part on ICE Windchill is created for each Find Number on the drawing. (Paragraph 8.8.1.4)</i>			
W-4	<i>Companion files have a “content” association to a WT Part. (Paragraph 8.8.2.3)</i>			
W-5	<i>Drawings have a “content” association to one or more related WT Part objects on ICE Windchill. (Paragraph 8.8.2.4)</i>			
W-6	<i>Deleted.</i>			

**CHECK THE MASTER LIST  
VERIFY THAT THIS IS THE CORRECT VERSION BEFORE USE**



<b>MSFC Technical Standard EV32</b>		
<b>Title: Computer-Aided Design (CAD) Standard</b>	<b>Document No.: MSFC-STD-3528 Effective Date: 10-JAN-2017</b>	<b>Revision: Revision E Page 97 of 98</b>

## **APPENDIX E**

### List of Desktop Instructions

<u><b>DI Number</b></u>	<u><b>DI Title</b></u>
ED-CAD-DI-001	Workspace Use and Troubleshooting
ED-CAD-DI-002	Naming and Renaming Files in ICE Windchill
ED-CAD-DI-003	Library Components
ED-CAD-DI-004	Standard Drawing Notes
ED-CAD-DI-005	Simplified Representation Creation and Maintenance
ED-CAD-DI-006	Creation of Skeleton Files
ED-CAD-DI-007	Standard Symbols
ED-CAD-DI-008	Updating Drawing Formats
ED-CAD-DI-009	MOD File Creation
ED-CAD-DI-010	Shrinkwrap Creation
ED-CAD-DI-011	Data Transfer
ED-CAD-DI-012	Casting and Forging Creation
ED-CAD-DI-013	Standard Barrel Panels
ED-CAD-DI-014	Cable Routing
ED-CAD-DI-015	Piping
ED-CAD-DI-016	Related Companion Files
ED-CAD-DI-017	Creating Standard Layers
ED-CAD-DI-018	Sheet Metal Parts
ED-CAD-DI-019	Adding Materials and Generating Mass Properties
ED-CAD-DI-020	User-Defined Features
ED-CAD-DI-021	Gears, Splines, and Sprockets
ED-CAD-DI-022	Vendor Item Modeling
ED-CAD-DI-023	Exploded Views
ED-CAD-DI-024	Tables and Tabulated Drawings
ED-CAD-DI-025	Bulk Items
ED-CAD-DI-026	Verifying 3-Dimensional CAD Models
ED-CAD-DI-027	Revising CAD Documents and WT Parts
ED-CAD-DI-028	Physical Interface Matrix Creation
ED-CAD-DI-029	Modeling of Composites
ED-CAD-DI-030	Gathering Released Data in ICE Windchill
ED-CAD-DI-031	Ground Strap Creation
ED-CAD-DI-032	Folder Structure
ED-CAD-DI-033	Create, Revise, Modify, and Promote
ED-CAD-DI-034	Modular Product Architecture
ED-CAD-DI-035	Computer-Aided Design (CAD) Management Prior to Release
ED-CAD-DI-036	Preparation and Processing of a ICE Windchill Change Request for CAD and WT Part Release

**CHECK THE MASTER LIST  
VERIFY THAT THIS IS THE CORRECT VERSION BEFORE USE**

MSFC Technical Standard EV32		
<b>Title: Computer-Aided Design (CAD) Standard</b>	<b>Document No.: MSFC-STD-3528</b>	<b>Revision: Revision E</b>
	<b>Effective Date: 10-JAN-2017</b>	<b>Page 98 of 98</b>

## APPENDIX F

### Recommended Hole Sizes

General Purpose Structural Applications											High Strength Structural Applications							
Class I - Pre-Drill Individual Parts						Class II - Drill On Assembly												
Bolt Dia and Limits		Oversize Fit		Loose Fit		Clearance Fit		Close Fit		Tight Fit		Close Tolerance Bolt Dia and Limits		Tight Fit Non Interference		Drive or Interference Fit		
HOLE SIZES AND CLEARANCES ARE BASED ON USE OF ANY BOLT OR SCREW WHICH COMES WITHIN THE NOTED LIMITS.		FOR USE WHERE HOLE PATTERN BRIDGES SEVERAL UNITS. NONSTRESSED ACCESS DOORS AND MANY EQUIPMENT ITEMS.		FOR TENSION ATTACHMENT WITH ONLY INCIDENTAL SHEAR LOADS AND FOR GENERAL BRACKET ATTACHMENT. ETC. WHERE VIBRATION OR HAMMERING ARE NOT PRESENT.		FOR GENERAL SHEAR LOAD ATTACHMENTS WHERE MULTIPLE BOLTS ARE USED AND USUALLY NON REVERSING LOADS.		FOR SHEAR LOAD ATTACHMENTS INVOLVING ONLY ONE TIGHT BOLT WHICH IS HIGHLY STRESSED OR SUBJECTED TO FREQUENT REVERSING LOADS. MULTI-BOLT PATTERNS MUST BE DRILLED ON ASSEMBLY.		FOR CLASS II CONNECTIONS WHICH ARE REMOVABLE. USE FOR HIGH SHEAR TRANSFER IN MAJOR STRUCTURE.		HOLE SIZES AND CLEARANCES ARE BASED ON USE OF ANY BOLT OR SCREW WHICH COMES WITHIN THE NOTED LIMITS.		FOR CLASS II CONNECTIONS PERMANENT JOINT. WHERE INTERFERENCE FIT IS UNDESIRABLE.		FOR CLASS II CONNECTIONS PERMANENT JOINT. NO MOVEMENT BETWEEN PARTS.		
Size	Limits (Dia)	Hole Size	Clearance (Ref)	Hole Size	Clearance (Ref)	Hole Size	Clearance (Ref)	Hole Size	Clearance (Ref)	Hole Size	Clearance (Ref)	Size	Limits (Dia)	Hole Size	Clearance (Ref)	Hole Size	Clearance (Ref)	
#4		.166 .180		.140 .152														
#6		.193 .208		.166 .180														
#8		.219 .233		.193 .208														
#10	.189 .186	.246 .260		.219 .233	.030 .047	.199 .202	.010 .016	.190 .194	.001 .008	.1895 .1905	.0005 .0045							
1/4	.249 .246	.302 .316	.053 .070	.277 .290	.028 .044	.257 .261	.008 .015	.250 .254	.001 .008	.2495 .2505	.0005 .0045	1/4	.2492 .2487	.2495 .2505	.0003 .0018	.2489 .2505	-.0003 .0018	
5/16	.312 .309	.368 .382	.056 .073	.339 .353	.027 .044	.323 .327	.011 .018	.3125 .316	.0005 .007	.3120 .3130	.0000 .0040	5/16	.3117 .3112	.3120 .3130	.0003 .0018	.3114 .3130	-.0003 .0018	
3/8	.374 .371	.437 .454	.063 .083	.406 .422	.032 .051	.386 .390	.012 .019	.375 .379	.001 .008	.3745 .3755	.0005 .0045	3/8	.3742 .3737	.3745 .3755	.0003 .0018	.3739 .3755	-.0003 .0018	
7/16	.437 .433	.500 .516	.063 .083	.469 .485	.032 .052	.453 .457	.016 .024	.4375 .442	.0005 .009	.4370 .4380	.0000 .0050	7/16	.4367 .4362	.4370 .4380	.0003 .0018	.4364 .4380	-.0003 .0018	
1/2	.499 .495	.562 .578	.063 .083	.531 .547	.032 .052	.516 .521	.017 .026	.500 .505	.001 .010	.4995 .5005	.0005 .0055	1/2	.4991 .4986	.4995 .5005	.0004 .0019	.4988 .5005	-.0003 .0019	
9/16	.562 .558	.625 .641	.063 .083	.593 .610	.031 .052	.578 .583	.016 .025	.5625 .567	.0005 .009	.5620 .5630	.0000 .0050	9/16	.5616 .5611	.5620 .5630	.0004 .0019	.5613 .5630	-.0003 .0019	
5/8	.624 .620	.687 .704	.063 .084	.656 .672	.032 .052	.641 .646	.017 .026	.625 .630	.001 .010	.6245 .6255	.0005 .0055	5/8	.6240 .6234	.6245 .6255	.0005 .0021	.6237 .6255	-.0003 .0021	
3/4	.749 .744	.812 .832	.063 .088	.781 .801	.032 .057	.766 .773	.017 .029	.750 .757	.001 .013	.7495 .7505	.0005 .0065	3/4	.7488 .7481	.7495 .7505	.0007 .0024	.7485 .7505	-.0003 .0024	
7/8	.874 .869	.937 .958	.083 .089	.906 .926	.032 .057	.891 .898	.017 .029	.875 .882	.001 .013	.8745 .8755	.0005 .0065	7/8	.8737 .8729	.8745 .8755	.0008 .0026	.8735 .8755	-.0002 .0026	
1	.999 .993	1.062 1.082	.063 .089	1.031 1.051	.032 .058	1.016 1.026	.017 .033	1.000 1.010	.001 .017	.9995 1.0005	.0005 .0075	1	.9985 .9975	.9995 1.0005	.0010 .0030	.9985 1.0005	.0000 .0030	

**CHECK THE MASTER LIST  
VERIFY THAT THIS IS THE CORRECT VERSION BEFORE USE**