



National Aeronautics and
Space Administration

**MEASUREMENT SYSTEM
ENGLISH/METRIC (SI)**

MSFC-SPEC-3679
REVISION A
EFFECTIVE DATE: October 22, 2018

George C. Marshall Space Flight Center
Marshall Space Flight Center, Alabama 35812

EM30

MSFC TECHNICAL STANDARD

**PROCESS SPECIFICATION -
WELDING AEROSPACE
HARDWARE**

Approved for Public Release; Distribution is Unlimited

CHECK THE MASTER LIST – VERIFY THAT THIS IS CORRECT VERSION BEFORE USE

MSFC Technical Standard EM30		
Title: Process Specification – Welding Aerospace Hardware	Document No.: MSFC-SPEC-3679	Revision: A
	Effective Date: October 22, 2018	Page 2 of 92

DOCUMENT HISTORY LOG

Status (Baseline/ Revision/ Cancelled)	Document Revision	Effective Date	Description
Baseline	-	10/11/2012	Baseline Release; document authorized through MPDMS. [Baselined by Upper Stage Element Control Board Directive CE4-01-0239, (PCN CE001107, CR CLV-US-0481).]
Revision	A	10/22/2018	Added section 1.3 – Units of Measurement. Moved sections 1.4 – Safety and 1.5 – Specific Process Weld Requirements to section 3.0 – Requirements. Added CGA specifications and removed cancelled gas specifications from section 2.0 – Applicable Standards and Documents. Moved Acronyms and Definitions from section 3.0 to Appendix I – Acronyms and Definitions. Removed section 5.1.5 – Weld Equipment Requalification and added section 5.1.10 – Weld Equipment Modification. Clarified section 7.3.2 – Weld Testing Methodology. Moved section 9.5.2.b – Equipment Fluctuations to Section 5.1 – Welding Equipment. Reformatted Tables in Appendix A. Clarified intent of Confidence Weld Requirements and moved sections within 7.3 for a logical approach.

CHECK THE MASTER LIST – VERIFY THAT THIS IS CORRECT VERSION BEFORE USE

MSFC Technical Standard EM30		
Title: Process Specification – Welding Aerospace Hardware	Document No.: MSFC-SPEC-3679	Revision: A
	Effective Date: October 22, 2018	Page 3 of 92

TABLE OF CONTENTS

<u>PARAGRAPH</u>	<u>PAGE</u>
1.0 SCOPE	8
1.1 Purpose.....	8
1.2 Applicability	8
1.3 Units of Measurement.....	9
1.4 Tailoring.....	9
2.0 APPLICABLE DOCUMENTS.....	10
2.1 Applicable Standards and Documents	10
2.2 Reference Documents	12
2.3 Order of Precedence.....	12
3.0 REQUIREMENTS.....	13
3.1 Safety	13
3.2 Specific Process Weld Requirements	13
4.0 JOINT CLASSES.....	14
4.1 Inspection Criteria.....	14
4.2 Joint Classifications	14
5.0 EQUIPMENT	15
5.1 Welding Equipment	15
5.2 Tooling and Fixtures.....	16
5.3 Electron Beam Welding.....	17
6.0 MATERIALS	18
6.1 Base Metals.....	18
6.2 Filler Metals	18
6.3 Shielding Gas	18
6.4 Tungsten Electrodes.....	19
6.5 FSW Pin Tools.....	19
6.6 Anvils and Plug Weld Backing Material	19
6.7 Friction Plugs.....	19

CHECK THE MASTER LIST – VERIFY THAT THIS IS CORRECT VERSION BEFORE USE

MSFC Technical Standard EM30		
Title: Process Specification – Welding Aerospace Hardware	Document No.: MSFC-SPEC-3679	Revision: A
	Effective Date: October 22, 2018	Page 4 of 92

- 7.0 WELDER PERFORMANCE AND WELD PROCEDURE QUALIFICATION..... 20**
- 7.1 Welder Performance Qualification 20
- 7.2 Weld Procedure Specification..... 20
- 7.3 Procedure Qualification Records 22
- 7.4 Records 24
- 8.0 PREWELD OPERATIONS..... 25**
- 8.1 Weld Joint Design..... 25
- 8.2 Preweld Cleaning 25
- 8.3 Preweld Joint Fit-up..... 26
- 8.4 Weld Start and Run-Off Tabs 27
- 8.5 Laser and Electron Beam-to-Joint Alignment 27
- 9.0 PRODUCTION WELDING 28**
- 9.1 Equipment Operational Readiness Check..... 28
- 9.2 Temperature Control..... 28
- 9.3 Tack Welding..... 28
- 9.4 Welding Techniques 28
- 9.5 Welding Procedure..... 29
- 10.0 POSTWELD OPERATION..... 30**
- 10.1 The Weldment..... 30
- 10.2 General Workmanship Requirements 30
- 10.3 Dimensional Requirements..... 30
- 10.4 Weldment Straightening 33
- 10.5 Postweld Heat Treatment Requirements..... 34
- 10.6 Weldment Quality Requirements..... 34
- 10.7 Repair Welding 34
- 10.8 Material Review Board..... 35
- 11.0 VERIFICATION..... 36**
- 11.1 General..... 36
- 11.2 Postweld Inspection 36
- 11.3 Records 37

CHECK THE MASTER LIST – VERIFY THAT THIS IS CORRECT VERSION BEFORE USE

MSFC Technical Standard EM30		
Title: Process Specification – Welding Aerospace Hardware	Document No.: MSFC-SPEC-3679	Revision: A
	Effective Date: October 22, 2018	Page 5 of 92

LIST OF APPENDICES

<u>Appendix</u>	<u>Page</u>
Appendix A Procedure Qualification Weld Strength Requirements	39
Appendix B Weld Joint Dimensional Requirements	44
Appendix C Weld Nugget Dimensional Requirements	46
Appendix D Weld Quality Requirements	65
Appendix E Weld Procedure Specification Information	73
Appendix F Recommended Weld Filler Metals	75
Appendix G Preweld and Postweld Cleaning Methods	82
Appendix H Reference Documents	83
Appendix I Acronyms and Definitions	85

MSFC Technical Standard EM30		
Title: Process Specification – Welding Aerospace Hardware	Document No.: MSFC-SPEC-3679	Revision: A
	Effective Date: October 22, 2018	Page 6 of 92

LIST OF TABLES

<u>Table</u>	<u>Page</u>
Table I. Minimum Inspection Requirements	14
Table II. WPS Allowable Qualified Thickness Range	20
Table III. GTAW Process Butt Weld Ultimate Tensile Strength Requirements	40
Table IV. VPPA Process Butt Weld Ultimate Tensile Strength Requirements.....	41
Table V. FSW Process Butt Weld Ultimate Tensile Strength Requirements	41
Table VI. Close-out FPW in FSW Process Ultimate Tensile Strength Requirements	42
Table VII. Fusion Butt Weld Ultimate Tensile Strength Requirements for Superalloys	43
Table VIII. Fusion Butt Weld Ultimate Tensile Strength Requirements for Titanium Alloys.....	43
Table IX. Fusion Butt Weld Ultimate Tensile Strength Requirements for Stainless Steel Alloys...	43
Table X. Preweld Joint Fit-up Requirements.....	44
Table XI. Postweld Joint Fit-up Requirements.....	45
Table XII. Dimensional Requirements for Butt Welds – Fusion ¹	46
Table XIII. Dimensional Characteristics of Aluminum Alloy Butt Welds	50
Table XIV. Dimensional Requirements.....	52
Table XV. Weld Surface and Volumetric Acceptance Criteria – Aluminum Alloys.....	65
Table XVI. Surface and Volumetric Acceptance Criteria – Steels, Heat Resistant Alloys.....	71
Table XVII. Weld Surface and Volumetric Acceptance Criteria – Titanium Alloys.....	72
Table XVIII. Recommended Parameters to be Recorded in a WPS.....	73
Table XIX. Filler Alloys Recommended for Aluminum Alloys and Combinations	75
Table XX. Filler Alloys Recommended for Carbon and Low Alloy Steels and Combinations.....	76
Table XXI. Filler Alloys Recommended for Stainless Steels and Combinations	77
Table XXII. Filler Alloys Recommended for Nickel- and Cobalt-Base Alloys and Combinations.	79
Table XXIII. Filler Alloys Recommended for Copper Alloys and Combinations	81
Table XXIV. Filler Alloys Recommended for Titanium Alloys and Combinations	81
Table XXV. Acceptable Preweld and Postweld Cleaning Methods.....	82

CHECK THE MASTER LIST – VERIFY THAT THIS IS CORRECT VERSION BEFORE USE

MSFC Technical Standard EM30		
Title: Process Specification – Welding Aerospace Hardware	Document No.: MSFC-SPEC-3679	Revision: A
	Effective Date: October 22, 2018	Page 7 of 92

LIST OF FIGURES

<u>Figure</u>	<u>Page</u>
Figure 1. Welding Techniques	29
Figure 2. Mismatch and Peaking	31
Figure 3. Fillet Weld Throats.....	32
Figure 4. Fillet Welds	33
Figure 5. Aluminum Fusion Butt Weld	46
Figure 6. EBW Butt Weld.....	47
Figure 7. EBW Max Weld Crown and Root Widths for Penetration Depths (D) ≤ 1.6 in [41 mm]	48
Figure 8. Min EBW Root Width for Penetration Depths (D) ≤ 0.2 in [5 mm].....	49
Figure 9. Min EBW Root Width for Penetration Depths (D) of 0.2-1.6 in [5-41 mm].....	50
Figure 10. C-FSW Zone.....	51
Figure 11. SR-FSW Zone	51
Figure 12. Titanium Full-Penetration Joint Welds	53
Figure 13. Titanium Butt Joint Maximum Allowable Weld Width (W) versus Thickness (t)	54
Figure 14. Titanium Fillet Joint Maximum Allowable Weld Width versus Thickness.....	55
Figure 15. Titanium Maximum Fillet Weld Size L_{MIN} = thickness of the thinnest member	56
Figure 16. Titanium Fillet Weld Dimensions for Acute Angle and Drop Through	56
Figure 17. Weld Size Requirements for Butt Welds.....	57
Figure 18. Class A Butt Weld Fusion Zone Weld Size Limits.....	58
Figure 19. Class B Butt Weld Fusion Zone Weld Size Limits	59
Figure 20. Class C Butt Weld Fusion Zone Weld Size Limits	60
Figure 21. Weld Size Requirements for T and Corner Welds	61
Figure 22. Class A, T and Corner Weld Fusion Zone Weld Size Limits	62
Figure 23. Class B, T and Corner Weld Fusion Zone Weld Size Limits.....	63
Figure 24. Class C, T and Corner Weld Fusion Zone Weld Size Limits.....	64
Figure 25. External Discontinuities for Aluminum Alloys.....	69
Figure 26. Internal Defects for Aluminum Alloys.....	70
Figure 27. EBW Porosity Acceptance Criteria for Steels, Heat Resistant.....	72
Figure 28. Conventional-Friction Stir Welding Process.....	90
Figure 29. Self Reacting-Friction Stir Welding Process.....	90

CHECK THE MASTER LIST – VERIFY THAT THIS IS CORRECT VERSION BEFORE USE

MSFC Technical Standard EM30		
Title: Process Specification – Welding Aerospace Hardware	Document No.: MSFC-SPEC-3679	Revision: A
	Effective Date: October 22, 2018	Page 8 of 92

1.0 SCOPE

This process specification establishes uniform requirements for the design, fabrication, and inspection of welds in flight hardware. This process specification may also be used for special test articles and ground support equipment. This specification combines the lessons learned from extensive Agency-wide welding engineering experiences and combines the requirements of project, Center, other government, and industry documents used for the manufacture of historic spaceflight hardware such as Saturn, the Space Shuttle, and the International Space Station.

When this process specification is specified on contract documents, the contractor may submit an alternative, corporate, detailed weld process specification that meets the intent of this specification. Industry, government, and company specifications may be used for welding hardware in lieu of this specification if approved by the responsible National Aeronautics and Space Administration (NASA) Technical Authority. The content of this process specification meets the intent of NASA-STD-5006A.

1.1 Purpose

The purpose of this process specification is to establish the minimum process control requirements for the design, fabrication (including the qualification of welders, welding operators, and welding procedure specifications), and quality assurance of manual, semi-automatic, mechanized, and automatic welds in flight hardware, special test articles and ground support equipment used by or for Marshall Space Flight Center (MSFC). This process specification will be used for flight hardware. This process specification may be used on special test articles and ground support equipment.

1.2 Applicability

This process specification is approved for use by MSFC and may be cited in contract, program, and other documents as a technical requirement. This process specification may also apply to contractors and subcontractors to the extent specified or referenced in their contracts.

This standard applies the following convention: all mandatory actions (i.e., requirements) are denoted by statements containing the term “shall”, the term “will” denotes an expected outcome, and the terms “may” or “should” denote explanatory or guidance text indicated in italics beginning in Section 4.0.

1.2.1 Applicable Processes

This process specification is applicable to fusion arc, solid-state, resistance and high-energy density weld processes for joining metallic materials. These include, but are not limited to, the following and the pulsed derivate:

- | | |
|---------------------------------------|---|
| (1) FCAW - Flux-Cored Arc Welding | (6) SAW - Submerged Arc Welding |
| (2) GMAW - Gas Metal Arc Welding | (7) VPPA - Variable Polarity Plasma Arc |
| (3) GTAW - Gas Tungsten Arc Welding | (8) Direct Drive Friction Welding |
| (4) PAW - Plasma Arc Welding | (9) Inertia Friction Welding |
| (5) SMAW - Shielded Metal Arc Welding | (10) FRW - Friction Welding |

CHECK THE MASTER LIST – VERIFY THAT THIS IS CORRECT VERSION BEFORE USE

MSFC Technical Standard EM30		
Title: Process Specification – Welding Aerospace Hardware	Document No.: MSFC-SPEC-3679	Revision: A
	Effective Date: October 22, 2018	Page 9 of 92

- | | |
|----------------------------------|----------------------------------|
| (11) FSW - Friction Stir Welding | (13) EBW - Electron Beam Welding |
| (12) FPW - Friction Plug Welding | (14) LBW - Laser Beam Welding |

1.2.2 Applicable Materials

This process specification covers all metallic materials used in the manufacture of flight hardware.

1.3 Units of Measurement

This standard makes use of both U.S. Customary Units (US) and the International System of Units (SI). The latter are shown within brackets ([]) or in appropriate columns in tables and figures. The measurements may not be exact equivalents, therefore, each system must be used independently.

1.4 Tailoring

Tailoring of this process specification shall be formally documented as part of the program or project requirements and approved by the responsible NASA Technical Authority. These requirements may be tailored by constructing a matrix of applicable paragraphs and non-applicable paragraphs. Tailoring may include using existing or previously developed contractor processes and standards as a submittal of the various required plans. Otherwise, the tailoring of requirements may be documented in the Materials and Processes Selection, Control, and Implementation Plan by providing the degree of conformance and the method of implementation for each requirement identified herein.

MSFC Technical Standard EM30		
Title: Process Specification – Welding Aerospace Hardware	Document No.: MSFC-SPEC-3679	Revision: A
	Effective Date: October 22, 2018	Page 10 of 92

2.0 APPLICABLE DOCUMENTS

2.1 Applicable Standards and Documents

The latest issues of the following documents form a part of this specification to the extent specified herein. In the event of a conflict between the documents referenced herein and the contents of this specification, the content of this specification will take precedence. The contractor may pursue substituting equivalent specifications and documents to the ones identified herein as long as the substitution does not compromise the intent of the specifications and documents identified herein and is approved by NASA/MSFC before implementation.

2.1.1 Military

MIL-HDBK-1823	Nondestructive Evaluation System Reliability Assessment
MIL-A-18455	Argon, Technical
MIL-PRF-27401	Propellant Pressurizing Agent, Nitrogen
MIL-PRF-27407	Propellant Pressurizing Agent, Helium
BB-C-101	Federal Specification Carbon Dioxide (CO ₂): Technical and USP
BB-H-886	Federal Specification Hydrogen
CGA G-4.3	Commodity Specification for Oxygen
CGA G-5.3	Commodity Specification for Hydrogen
CGA G-6.2	Commodity Specification for Carbon Dioxide
CGA G-9.1	Commodity Specification for Helium
CGA G-10.1	Commodity Specification for Nitrogen
CGA G-11.1	Commodity Specification for Argon

2.1.2 National Aeronautics and Space Administration (NASA)

NASA-STD-5006A	General Fusion Requirements for Aerospace Materials Used in Flight Hardware
NASA-STD-5009	Nondestructive Evaluation Requirements for Fracture-Critical Metallic Component
NASA-STD-5019	Fracture Control Requirements for Spaceflight Hardware
NASA-STD- 6016	Standard Materials and Processes Requirements for Spacecraft

CHECK THE MASTER LIST – VERIFY THAT THIS IS CORRECT VERSION BEFORE USE

MSFC Technical Standard EM30		
Title: Process Specification – Welding Aerospace Hardware	Document No.: MSFC-SPEC-3679	Revision: A
	Effective Date: October 22, 2018	Page 11 of 92

NASA-STD-8739.12	Metrology and Calibration
MPCV 7016	Cross Program Fluid Procurement and Use Control Specification
NPR 8715.1	NASA Occupational Safety and Health Program
NPR 1441.1	NASA Records Management Program Requirements

2.1.3 Other Publications

ASTM E8/E8M	Standard Test Methods for Tension Testing of Metallic Materials
AWS A2.4	Standard Symbols for Welding, Brazing, and Nondestructive Examination
AWS A3.0	Standard Welding Terms and Definitions
AWS A5-ALL	Filler Metal Procurement Guidelines
AWS A5.01M/A5.01	Welding Consumables – Procurement of Filler Metals and Fluxes
AWS A5.12M/A5.12	Specification for Tungsten and Oxide Dispersed Tungsten Electrodes for Arc Welding and Cutting
AWS B2.1/B2.1M	Specification for Welding Procedure and Performance Qualification
AWS B4.0	Standard Methods for Mechanical Testing of Welds
AWS C6.1	Recommended Practices for Friction Welding
AWS C6.2	Specification for Friction Welding of Metals
AWS C7.4/C7.4 M	Process Specification and Operator Qualification for Laser Beam Welding
AWS D17.1	Specification for Fusion Welding for Aerospace Applications
AWS D17.2/D17.2 M	Specification for Resistance Welding for Aerospace Applications
AWS D17.3	Specification for Friction Stir Welding of Aluminum Alloys for Aerospace Applications
AWS G2.4/G2.4 M	Guide for the Fusion Welding of Titanium and Titanium Alloys
AWS QC1	Standard for AWS Certification of Welding Inspectors
NAS 410	NAS Certification & Qualification of Nondestructive Test Personnel

CHECK THE MASTER LIST – VERIFY THAT THIS IS CORRECT VERSION BEFORE USE

MSFC Technical Standard EM30		
Title: Process Specification – Welding Aerospace Hardware	Document No.: MSFC-SPEC-3679	Revision: A
	Effective Date: October 22, 2018	Page 12 of 92

- | | |
|-----------------|---|
| NAS 1514 | Radiographic Standard for Classification of Fusion Weld Discontinuities |
| SAE AMS 2680 | Electron-Beam Welding for Fatigue Critical Applications |
| SAE AMS 2770 | Heat Treatment of Aluminum Alloy Raw Material |
| SAE AMS-W-6858A | Welding, Resistance: Spot and Seam |

2.2 Reference Documents

The documents listed in Appendix H are provided as background information for users of this specification, defining the source of the requirements in sections 4.0 through 11.0 of this specification. The listing in this section does not levy any new or relieve any specific requirements that are imposed by this specification or other contractual documents associated with procurement of this specification end item.

2.3 Order of Precedence

When requirements in this specification conflict with those on the engineering drawing, the requirements on the engineering drawing will take precedence. Conflicts between this specification and other requirements documents will be resolved by the responsible NASA Technical Authority.

MSFC Technical Standard EM30		
Title: Process Specification – Welding Aerospace Hardware	Document No.: MSFC-SPEC-3679	Revision: A
	Effective Date: October 22, 2018	Page 13 of 92

3.0 REQUIREMENTS

3.1 Safety

3.1.1 Industrial Safety

3.1.1.1 Appropriate personal protective equipment shall be used in all hazardous processes.

3.1.1.2 All hazardous materials and processes that are required in compliance with provisions of this process specification and that are located or performed at sites other than MSFC are subject to applicable federal, State, and local safety codes, standards, and regulations.

3.1.1.3 All hazardous materials and processes that are required in compliance with provisions of this process specification and that are located or performed at MSFC shall be subject to NPR 8715.1.

3.1.2 System Safety

3.1.2.1 System safety engineering (SSE) shall identify critical and catastrophic hazards and mitigations to eliminate and/or control the hazards of the welding operations.

3.1.2.2 SSE shall participate within the various program working groups, panel reviews, and procedures and drawing reviews of welding systems and processes.

3.1.2.3 SSE shall participate in welding process reviews and decisions to ensure that safety concerns are addressed and appropriate safety requirements and design criteria are implemented in accordance with applicable program Safety, Reliability, and Quality Plan.

3.2 Specific Process Weld Requirements

3.2.1 Resistance Welding

Resistance welding shall be in accordance with AWS D17.2/D17.2M, or SAE AMS-W-6858A.

3.2.2 Laser Beam Welding

LBW shall be in accordance with AWS C7.4/C7.4M.

3.2.3 Friction and Inertia Welding

Direct drive friction or inertia welding shall be in accordance with AWS C6.2.

MSFC Technical Standard EM30		
Title: Process Specification – Welding Aerospace Hardware	Document No.: MSFC-SPEC-3679	Revision: A
	Effective Date: October 22, 2018	Page 14 of 92

4.0 JOINT CLASSES

4.1 Inspection Criteria

4.1.1 Welds performed using this process specification shall be classified in accordance with the consequences of joint failure as described in the following sections.

4.1.2 Welds shall be inspected per Table I.

Table I. Minimum Inspection Requirements

Method of Inspection	Weld Class		
	A	B	C
Visual	X	X	X
Dimensional	X	X	X
Surface	X	X	–
Volumetric	X	X ¹	–
Additional Inspection When Required by Drawing	X	X	X

¹Class B welds shall be subjected to volumetric inspection if required by engineering design and specified by drawing or special instruction.

4.2 Joint Classifications

4.2.1 Class A Joints

4.2.1.1 A weld joint whose failure would result in loss of crew, loss of vehicle, or loss of mission shall be classified as a Class A joint.

4.2.1.2 Class A welds shall pass quantitative surface and volumetric NDE and visual inspection in accordance with Table I and Section 11.0.

4.2.1.3 Class A fillet welds shall require a Materials Usage Agreement (MUA) in accordance with NASA-STD-6016.

Based on consequences of failure, all fracture-critical welds are, by definition, Class A joints. If the quality of the Class A joint cannot be verified as required by this specification, e.g., inaccessible volume or root surfaces, then alternative rationale for acceptance is to be presented to the responsible NASA Fracture Control Board for approval as required by NASA-STD-5019.

4.2.2 Class B Joints

4.2.2.1 A fail-safe weld joint shall be classified as a Class B joint.

4.2.2.2 Class B welds shall pass quantitative NDE and visual inspection in accordance with Table I and Section 11.0.

4.2.3 Class C Joints

4.2.3.1 A nonstructural weld joint shall be classified as a Class C joint.

4.2.3.2 Class C welds shall pass a visual inspection in accordance with Table I and Section 11.0.

4.2.3.3 Class C welds shall be fully contained so failure in service would have minor or no effect on the efficiency of a system and so endangerment to personnel would not occur.

MSFC Technical Standard EM30		
Title: Process Specification – Welding Aerospace Hardware	Document No.: MSFC-SPEC-3679	Revision: A
	Effective Date: October 22, 2018	Page 15 of 92

5.0 EQUIPMENT

5.1 Welding Equipment

5.1.1 All welding equipment shall be capable of producing welds that meet the quality requirements specified herein.

5.1.2 Welding equipment shall be procured in accordance with an approved specification.

5.1.3 Equipment parametric fluctuations, variations that occur in equipment without human intervention, shall be characterized by the equipment vendor and may not be cause for rejection.

5.1.4 Violations of tolerances related to equipment variations during the steady-state portion of the weld that occur for less than 6 seconds shall not be cause for rejection.

Variations caused by the sampling rate per second can cause the readings to be outside the certified range. As long as the number is random (hence, the 6-sec limit), it is not cause for rejection.

5.1.5 Weld parameters controlling the heat input for automatic and mechanized welds shall be recorded continuously using automatic recording devices during the weld operation.

5.1.5.1 Process parameter data shall be logged at a rate that sufficiently captures all essential variable data and minimizes the risk of signal artifacts.

The minimum recommended data capture rate for FSW is 5 Hz.

5.1.5.2 Process parameter log files shall be stored electronically in compliance with contractual requirements

5.1.5.3 Equipment fluctuations or natural variations that occur in equipment without human intervention and change the readings of the qualified nominal parameter settings shall not be cause for rejection.

5.1.6 EBW equipment shall be a high vacuum type for welding in 5×10^{-4} torr [6.7×10^{-2} Pa] (or better) vacuum.

5.1.7 Acceptance Testing

5.1.7.1 New or relocated welding machines shall be acceptance tested under the cognizance of the responsible organization before release to manufacturing departments for production welding.

5.1.7.2 Equipment shall meet the requirements of the applicable purchase specification or design specification.

5.1.7.3 All equipment (electrical and mechanical) shall operate reliably within the range of parameters and duty cycle to be used for welding of production parts.

5.1.8 Calibration

5.1.8.1 Calibration shall be in accordance with NASA-STD-8739.12. For MSFC operations, reference MPR 8730.5 in Appendix H.

5.1.8.2 Welding shall be accomplished using equipment containing calibrated data indicators within manufacturer-specified tolerance ranges that display and/or record welding parameters.

MSFC Technical Standard EM30		
Title: Process Specification – Welding Aerospace Hardware	Document No.: MSFC-SPEC-3679	Revision: A
	Effective Date: October 22, 2018	Page 16 of 92

5.1.8.3 Measuring instruments, meters, gauges, or direct reading electrical control circuits to be used for welding operations shall be calibrated.

5.1.8.4 Calibration shall be verified periodically at intervals specified by the manufacturer of the welding equipment, not to exceed 1 year, or when any maintenance or repair is performed that may have changed calibration.

5.1.8.5 Current calibration status shall be posted or made available at the equipment and verified prior to use.

5.1.8.6 Calibration record(s) shall be maintained by the responsible cognizant organization and made available upon request.

The office of record for MSFC calibration records is the MSFC Metrology and Calibration Laboratory.

5.1.9 Maintenance and Maintenance Records

5.1.9.1 A preventive maintenance plan shall be implemented for welding equipment.

5.1.9.2 Welding machines shall have adequate periodic preventive maintenance service.

5.1.9.3 A current record of each maintenance repair shall be maintained for each welding machine.

5.1.9.4 Maintenance records shall be maintained by the responsible cognizant organization and made available upon request.

5.1.9.5 Records shall include unique identification of equipment, date, and time of service/repair, description of work completed, and traceability to employee performing the maintenance.

5.1.10 Weld Equipment Modification

5.1.10.1 Weld equipment validation shall be required when the welding equipment has failed to accomplish the intended function or when any major modification is made to the equipment.

Major modifications may include any changes to relevant sensor equipment, support hardware, software, or the weld system affecting process control.

5.1.10.2 When any major modification is made to the equipment a validation plan shall be submitted to the responsible NASA Technical Authority for approval.

5.1.10.3 Equipment validation documentation shall be retained as temporary records per section 11.3.7 and made available upon request.

5.2 Tooling and Fixtures

5.2.1 General Requirements

5.2.1.1 Tooling and fixtures shall be identified in the Weld Procedure Specification (WPS).

5.2.1.2 Tooling and fixtures used in the welding operation shall be constructed of materials that do not adversely affect the weld process and are not detrimental to the weld quality.

5.2.1.3 Tooling and fixtures shall not be a source of contamination of the weld or of the part being welded.

MSFC Technical Standard EM30		
Title: Process Specification – Welding Aerospace Hardware	Document No.: MSFC-SPEC-3679	Revision: A
	Effective Date: October 22, 2018	Page 17 of 92

5.2.1.4 Fixtures within 2 in. [5 cm] of the weld joint shall be visually free from rust, oxide scale, dirt, oil, grease, paint, low melting alloys, e.g., lead, tin, cadmium, and other contaminants detrimental to weld quality.

Paint may be within 1 in. [2.5 cm] on FSW fixtures.

5.2.2 Clamping and Alignment

5.2.2.1 Tooling and fixtures shall maintain component alignment during welding and ensure compliance with dimensional requirements of section 10.3 of this process specification.

5.2.2.2 In FPW, there shall be contact between the component and the backing anvil.

5.2.3 Magnetic Materials

5.2.3.1 When used with arc or EBW, magnetic materials shall be degaussed before welding.

5.2.3.2 Degaussing of magnetic materials shall be controlled by the WPS when necessary for the successful completion of the weld.

5.2.3.3 Degaussing – Prior to welding, ferromagnetic parts or tooling which have been subjected to the influence of magnetic fields (e.g., GTAW tack welded, machined using magnetic chucks, or magnetic particle inspected) shall be degaussed prior to welding.

Degaussing is to prevent arc and electron beam deflection while welding the joint.

5.2.4 Chill Bars

5.2.4.1 Chill bars shall not be used in such a manner that the weld joint location surfaces pick up chill bar material.

Chrome-plated copper chill bars may be used because copper or copper alloys have resulted in liquid metal embrittlement of austenitic stainless steels and some cobalt alloys.

Electroless nickel plating introduces phosphorus, which is detrimental to the weld process.

5.2.4.2 Aluminum, aluminum alloys, or other low melting alloys shall not be used for chill bars for non-aluminum alloy weld joints.

5.3 Electron Beam Welding

5.3.1 EBW shall be performed in a vacuum with absolute pressure of 0.001 torr [0.133 Pa] or lower.

5.3.2 Back-up material used to deflect or absorb residual EBW energy shall be of the same alloy as the part being welded, except when authorized by the NASA Technical Authority.

Alternate back-up materials may be used when specified by the WPS.

MSFC Technical Standard EM30		
Title: Process Specification – Welding Aerospace Hardware	Document No.: MSFC-SPEC-3679	Revision: A
	Effective Date: October 22, 2018	Page 18 of 92

6.0 MATERIALS

6.1 Base Metals

6.1.1 Unless otherwise specified or approved by the procuring agency, the base metal alloy shall conform to applicable material specifications as defined on the engineering drawing.

6.1.2 The base metal type and condition, as well as the appropriate material specification shall be recorded as a part of the WPS.

6.1.3 Weld start and run-off tabs, when used, shall be of the same alloy as the material being joined and be welded with the same filler metal specified on the drawing or WPS.

Backing material may be used when authorized by the WPS.

6.2 Filler Metals

6.2.1 Weld filler materials shall be purchased according to AWS A5.01/A5.01M.

6.2.2 Unless otherwise specified or approved by the procuring agency, filler metal alloy shall conform to all AWS A5 filler metal material specifications (AWS A5-ALL).

6.2.3 Weld filler materials and the appropriate specifications shall be recorded on the WPS.

6.2.4 Weld filler materials shall be stored under conditions to maintain filler material cleanliness and quality.

6.2.5 Uncoated weld filler wires shall be identified with a unique identification placed at the lowest level of control, i.e., wire, package, tube, to ensure material traceability of all uncoated welding filler wires.

Recommended weld filler metals are listed in Appendix F.

6.2.6 Metal consumable inserts shall be certified, their material traceability maintained, and both recorded as part of the WPS.

6.2.7 Material traceability for friction plugs shall be ensured.

6.2.8 Commercially pure titanium filler metal shall not be used for joining Ti-6Al-4V weld joints.

6.3 Shielding Gas

6.3.1 Welding-grade gases conforming to the applicable industry or military specifications shall be used for gas shielding when required.

6.3.1.1 Argon gas shall conform to the requirements of MIL-A-18455 or CGA G-11.1.

6.3.1.2 Nitrogen gas shall conform to the requirements of MIL-PRF-27401 or CGA G10.1.

6.3.1.3 Oxygen gas shall conform to the requirements of CGA G-4.3.

6.3.1.4 Helium gas shall conform to the requirements of MIL-PRF-27407 or CGA G-9.1.

6.3.1.5 Hydrogen gas shall conform to the requirements of BB-H-886 or CGA G-5.3.

6.3.1.6 Carbon dioxide gas shall conform to the requirements of BB-C-101 or CGA G-6.2.

6.3.2 The shield gas type and flow rates shall be recorded as a part of the WPS.

CHECK THE MASTER LIST – VERIFY THAT THIS IS CORRECT VERSION BEFORE USE

MSFC Technical Standard EM30		
Title: Process Specification – Welding Aerospace Hardware	Document No.: MSFC-SPEC-3679	Revision: A
	Effective Date: October 22, 2018	Page 19 of 92

6.3.3 Inert gas back-side shielding shall be used on joints requiring full or partial penetration on alloys susceptible to heavy oxide formation on the root side, the formation of which cannot be removed by wire brushing and will interfere with surface inspection.

6.3.4 Only helium or argon shielding gas shall be used for welding titanium and titanium alloys.

6.4 Tungsten Electrodes

6.4.1 Tungsten electrodes shall conform to AWS A5.12/A5.12M.

6.4.2 The electrode diameter, tip shape and alloy shall be recorded as a part of the WPS.

6.5 FSW Pin Tools

6.5.1 FSW pin tools (shoulders and pins) and tack tools shall be made of materials that resist wear during welding.

6.5.2 Pin and shoulder service life shall be demonstrated to meet the intended use and the use of pins and shoulders limited to the demonstrated life.

6.5.3 Pins and shoulders that have reached the specified service life shall be marked and removed from service to preclude accidental future use in the FSW production process.

6.5.4 If used for more than one weld joint, pins and shoulders shall be cleaned and inspected as required before reuse on production hardware.

6.5.5 Pin tools shall be visually inspected after each production weld for unacceptable wear and damage. Cracks, pits, flakes, and missing or broken threads shall result in the rejection of the pin tool from use in production.

6.5.6 Findings of pin tool visual inspections shall be recorded and hardware welded with damaged pin tools dispositioned before acceptability for use.

6.5.7 Pin tool design and materials shall be recorded as part of the WPS.

6.6 Anvils and Plug Weld Backing Material

6.6.1 Unless otherwise specified or approved by the procuring agency, anvil materials shall conform to applicable government and/or industry specifications for each given alloy group.

6.6.2 Anvil material shall be resistant to deformation under the loads and temperatures experienced during C-FSW and FPPW.

6.6.3 Anvil material shall not chemically react with the components to be joined.

6.6.4 Anvil and plug weld backing materials shall be recorded as part of the WPS.

6.7 Friction Plugs

6.7.1 Unless otherwise specified or approved by the procuring agency, friction plug materials shall conform to applicable government and/or industry specifications for each given alloy group and their material traceability be ensured.

6.7.2 Plugs shall be stored in an area that precludes their degradation by humidity, contamination, or chemical attack.

6.7.3 Plug weld design and material shall be recorded as part of the WPS.

CHECK THE MASTER LIST – VERIFY THAT THIS IS CORRECT VERSION BEFORE USE

MSFC Technical Standard EM30		
Title: Process Specification – Welding Aerospace Hardware	Document No.: MSFC-SPEC-3679	Revision: A
	Effective Date: October 22, 2018	Page 20 of 92

7.0 WELDER PERFORMANCE AND WELD PROCEDURE QUALIFICATION

7.1 Welder Performance Qualification

7.1.1 Operators of welding equipment shall be certified by successful completion of a qualification test for the applicable process.

7.1.1.1 Each fusion welder or fusion welding operator shall be qualified in accordance with AWS D17.1, Section 5 and accepted to Class A requirements of this process specification.

7.1.1.1.1 All qualification groove welds shall be radiographically inspected.

7.1.1.1.2 All fillet welds with a base metal thickness more than 0.063 in [1.6 mm] shall be bend tested or examined metallographically.

Other requirements may be added but not be substituted for the requirements in AWS D17.1 Section 5.

7.1.1.2 FSW operators shall be qualified in accordance with AWS D17.3, Section 7 and accepted to Class A requirements of this process specification.

7.1.1.3 FPW operators shall be qualified in accordance with AWS D17.3, Section 7, using a square groove test weld in sheet for making plug welds accepted to Class A requirements of this process specification.

7.1.2 Welder qualification testing shall be repeated at intervals not exceeding 5 years or when there is evidence to question the ability of the welder or welding operator to meet the requirements for qualification.

7.1.3 To maintain qualification, welders and welding operators shall have performed the weld process on the alloy groups for which they are certified within the previous 6 months.

7.1.4 Proficiency demonstration shall be required if a welder or welding operator has not performed the weld process on the alloy groups for which they are certified within the previous 6 months.

7.1.5 Records of operator certification documentation shall be maintained by the contractor's quality assurance organization as temporary records per section 11.3.7 and be provided to the procuring agency before welding flight hardware.

7.2 Weld Procedure Specification

7.2.1 A WPS shall be qualified for each thickness and material combination. The allowable qualified thickness range is shown in Table II.

7.2.2 The WPS shall be qualified on the production equipment before welding of the first production part.

Table II. WPS Allowable Qualified Thickness Range

Process Application	Thickness (t) Range, in [mm]
Automatic	±0.020 [0.51]
Semi-Automatic	±0.020 [0.51]
Mechanized	±0.020 [0.51]
Manual	-0.5t / +2.0t
Orbital Tube	±0.1t

CHECK THE MASTER LIST – VERIFY THAT THIS IS CORRECT VERSION BEFORE USE

MSFC Technical Standard EM30		
Title: Process Specification – Welding Aerospace Hardware	Document No.: MSFC-SPEC-3679	Revision: A
	Effective Date: October 22, 2018	Page 21 of 92

Appendix E lists information that may be included in a WPS.

7.2.3 All test and evaluation data shall be recorded in the PQR.

7.2.4 The WPS shall contain all the information necessary to produce welds that consistently meet the strength and quality requirements.

7.2.4.1 All essential variables shall be identified on the WPS.

7.2.4.2 For weld qualification tests, base metal and consumables shall be identified by lot or heat number, type, and condition.

7.2.4.3 This base metal and consumable identification shall be maintained through all evaluation processes.

7.2.4.4 The WPS shall document all other prewelding operations, setup conditions, welding equipment, and any other pertinent information about the welding system used that affects the welding operation.

7.2.4.5 Operator trim parameter tolerances used for automatic, semi-automatic, and mechanized welding shall be listed in the qualified WPS.

7.2.5 Test samples representing the minimum and maximum heat input bounded in the WPS for automatic, semi-automatic, and mechanized welds shall be tested in accordance with section 7.3 of this process specification to verify acceptable welds

7.2.6 Procedure qualification welds shall be inspected using visual and NDE as specified in section 10.0 of this process specification, in accordance with Class A requirements.

7.2.6.1 Following visual and nondestructive inspection, the qualification welds shall be subjected to the same processes as the production parts, including reinforcement removal, mechanical deformation, stress relief, and thermal treatments associated with artificial aging or any operation affecting mechanical properties.

7.2.6.2 Rejectable surface indications may be removed using mechanical means (sanding or polishing), not rewelding. All visual and surface indications noted on the qualification welds that have been mechanically removed shall be recorded in accordance with section 7.3.1 and the records retained with the qualification weld documentation.

7.2.7 Operating ranges for current and voltage shall be established during the WPS qualification for the steady-state portion of manual welds.

7.2.8 Tapered thickness welds shall be qualified at the maximum and minimum thickness (see Table II) and with a full-length confidence weld (specified in section 7.3.4).

7.2.9 In recognition of the differences in welding conditions between a test panel fixture and a major weld tool, the weld schedule developed on the test panel fixture shall be adjusted to the degree necessary when welding on the major weld tool.

7.2.9.1 The variation shall be noted on the WPS.

7.2.9.2 The adjustment shall be allowed one time only on the first part welded on the major weld tool.

7.2.9.3 An adjustment approach that allows more than one adjustment shall be approved by the responsible NASA Technical Authority.

CHECK THE MASTER LIST – VERIFY THAT THIS IS CORRECT VERSION BEFORE USE

MSFC Technical Standard EM30		
Title: Process Specification – Welding Aerospace Hardware	Document No.: MSFC-SPEC-3679	Revision: A
	Effective Date: October 22, 2018	Page 22 of 92

7.2.9.4 A confidence weld shall be completed before welding production hardware in accordance with the requirements of 7.3.4.

7.3 Procedure Qualification Records

7.3.1 All test results, including visual, dimensional, and NDE, shall be recorded in the PQR.

The provisions of AWS B2.1/B2.1M, may be followed for fusion welds.

7.3.2 Weld Testing Methodology

Welds shall be tested in accordance with AWS B4.0. Alternative methods for weld performance qualification verification shall be approved by the NASA Technical Authority.

For FSW, weld process zones should be evaluated using the qualified WPS at panel and confidence weld level. Weld process zones may include intersections, weld overlap regions, restarts and closeout processes. This data should be evaluated to the vehicle design requirements.

7.3.2.1 Tensile Tests

7.3.2.1.1 A minimum of five specimens shall be tested to qualify a groove weld procedure.

7.3.2.1.2 Plug weld tensile test specimens gauge width shall be a minimum of 1.3 times the major diameter of the plug weld.

7.3.2.1.3 At a minimum, tensile specimens shall be tested to destruction at room temperature.

7.3.2.1.4 Percent elongation in 1.0 in. [2.5 cm] and/or 2.0 in. [5 cm] gauge lengths, 0.2% offset yield stress, and ultimate tensile strength shall be recorded.

7.3.2.1.5 Percent elongation for round samples shall be measured across a length of 4 times the diameter.

7.3.2.1.6 Weld strength shall meet or exceed the values in Appendix A.

7.3.2.1.7 Qualification welds for aluminum alloys used in cryogenic applications shall be tensile tested at the intended use cryogenic temperature and at room temperature.

(1) A minimum of four test specimens shall be tested to destruction.

7.3.2.2 Shear Tests

7.3.2.2.1 A minimum of five specimens shall be shear tested for fillet welds in corner, T, lap, or edge joint configuration to qualify the weld procedure.

When it is not feasible to fabricate shear test specimens from qualification welds, shear tests may be implemented in accordance with AWS B4.0.

7.3.2.2.2 The shear ultimate strength shall meet 60% of the weld ultimate tensile strength requirement shown in Appendix A, unless otherwise approved by the responsible NASA Technical Authority.

7.3.2.3 Metallographic Examination

7.3.2.3.1 The welded joint shall be sectioned transverse to the direction of welding and the surface adequately prepared for visual examination in an unetched condition at a magnification of 10X for weld characteristics and defects.

MSFC Technical Standard EM30		
Title: Process Specification – Welding Aerospace Hardware	Document No.: MSFC-SPEC-3679	Revision: A
	Effective Date: October 22, 2018	Page 23 of 92

7.3.2.3.2 The section shall be lightly etched to reveal microstructure and reexamined at a higher magnification (a minimum of 50X and not greater than 200X) for dimensional requirements and the following weld quality requirements:

- (1) Overall fusion or consolidation of the weld, root penetration, burn-through, and blowholes.
- (2) Convexity, concavity, and size of bead, nugget or fillet.
- (3) Undercutting, underthickness, and overlapping.
- (4) Inclusions or voids.
- (5) Cracks.

7.3.2.4 Titanium Chemistry

7.3.2.4.1 Titanium weld qualification samples shall be analyzed for hydrogen, oxygen, and nitrogen content, in accordance with the requirements of the base metal specification, to assure conformance to the purity requirements.

7.3.2.4.2 The level of interstitial gases in the completed weld shall not exceed the worst-case maximum level permissible in the procurement specification for the base materials being welded.

7.3.2.4.3 The weld cross section in titanium welds shall contain no titanium hydrides (TiH₂) or alpha case.

These two detrimental phenomena are indications of the hydrogen content exceeding the solubility limit and an oxygen-enriched alpha-stabilized surface resulting from air contamination at elevated temperatures, respectively.

7.3.3 Specimens described in section 7.3.2 of this process specification shall be produced and tested at a minimum interval of 5 years for Class A and Class B welds to verify PQR data.

Failed qualification welds that have anomalies with a clear definable cause may be repeated with a 2-for-1 replacement.

Additional testing (fatigue, simulated service, hardness, impact, etc.) may be performed in support of meeting the design requirements.

7.3.4 Confidence Weld Requirements

7.3.4.1 A confidence weld for each of the following different weld configurations shall be made and tested in accordance with section 7.3.2 of this process specification to validate the WPS. Class C welds are not required to have a confidence weld performed for qualification.

7.3.4.1.1 Tapered thickness welds made with automatic, semi-automatic, or mechanized weld processes.

7.3.4.1.2 Pressure vessel or pressurized structure welds; excluding pressurized component welds.

7.3.4.1.3 All SR-FSW.

7.3.4.1.4 All C-FSW.

7.3.4.1.5 Cases in which the procedure qualification weld does not provide an appropriate representation of the product form, e.g., forging, casting, extrusion, or geometry of the components being welded, e.g., tubing, rolled shape.

CHECK THE MASTER LIST – VERIFY THAT THIS IS CORRECT VERSION BEFORE USE

MSFC Technical Standard EM30		
Title: Process Specification – Welding Aerospace Hardware	Document No.: MSFC-SPEC-3679	Revision: A
	Effective Date: October 22, 2018	Page 24 of 92

7.3.4.1.6 Class A weld without root side access to verify full penetration.

7.3.4.1.7 Primary structural vehicle or payload welds. This may include payload attachment hardware or similar structures that constitute the primary load path within or between the vehicle and payload.

7.3.4.2 The confidence weld shall replicate the production part with respect to section thickness, alloy, heat treat condition, joint preparation, preweld cleaning, and fit-up and be made in the actual production weld fixture, using the actual production welding equipment.

7.3.4.3 The confidence weld shall replicate the production weld with respect to length, startup, and tailout or closeout.

7.3.4.3.1 A minimum of 15 total specimens shall be tested from the confidence weld(s).

- (1) Five specimens shall be taken from the beginning, five specimens from the middle, and five specimens from the end of the confidence weld. Specimen removal locations shall be approved by the NASA Technical Authority.
 - a) Beginning – As near the weld start as part geometry allows but outside of any overlap region
 - b) Middle – As near the weld midpoint as part geometry allows
 - c) End – As near the weld end as part geometry allows but prior to any overlap region
- (2) In FSW, the closeout process shall be tested at the service temperature.
- (3) For weldments of insufficient size or configuration, the NASA Technical Authority shall approve the test approach.

The pathfinder article may be used for the confidence weld if the above criteria are met.

7.3.5 Qualification shall be required if any of the essential variables on the WPS are modified.

7.4 Records

7.4.1 Records of test specimens that meet the acceptance requirements of this process specification shall be signed and dated by a Safety Mission Assurance (SMA) representative as an accurate record of the welding and testing of the procedure test weldment.

7.4.2 The WPS and PQR shall be prepared and retained as temporary records in accordance with section 11.3.7, with the current WPS being accessible at the welding station to the welder or welding operator.

7.4.3 All WPSs and PQRs shall be maintained and made available for review by the responsible NASA Technical Authority before production.

MSFC Technical Standard EM30		
Title: Process Specification – Welding Aerospace Hardware	Document No.: MSFC-SPEC-3679	Revision: A
	Effective Date: October 22, 2018	Page 25 of 92

8.0 PREWELD OPERATIONS

8.1 Weld Joint Design

8.1.1 Joint configurations shall be documented in the WPS and on the design drawing.

Acceptable joint designs are butt, lap, corner, T, and edge. Corner and T joint designs should be designed to minimize susceptibility to lamellar tearing.

8.1.2 Class A and Class B full-penetration weld joint configurations that will be inaccessible for root side inspection are subject to the requirements of section 7.3.4 and shall be identified on engineering drawings and require approval for use as a weld joint design by the responsible NASA Technical Authority.

8.1.2.1 For Class A welds, faying surfaces of joints shall have a surface roughness of 32 to 125 μin [0.81 to 3.2 μm] per ASME B46.1.

8.1.3 LBW and EBW weld joint edges shall be machined parallel to ensure proper fit-up and meet the preweld joint fit-up requirements in Appendix B.

8.1.4 FSW joint design shall be butt joint configuration only.

8.1.5 Plug weld joint preparation shall be performed per the WPS or Engineering Drawing. This may include deburring.

8.2 Preweld Cleaning

8.2.1 Preweld cleaning of contaminants detrimental to weld quality or filler materials and surfaces to be welded shall be in accordance with Appendix G.

8.2.2 Preweld cleaning shall be accomplished in a controlled environment that does not degrade weld quality and that is maintained until the weld operation is complete.

8.2.3 After surface preparation, parts shall be covered or otherwise protected to prevent contamination until welding is completed.

8.2.4 Personnel performing the cleaning operation or any subsequent operation shall wear powder-free, non-vinyl, moisture barrier gloves.

8.2.5 Before use, tooling (including hold-down clamps, anvils, and parts of welding fixtures that contact or are placed in close proximity to the weld joint) shall be free of oil, moisture, and foreign materials.

8.2.6 Tools and instruments used for measurements or other devices that contact the surfaces to be welded shall be free of oil, grease, moisture, or other foreign materials before use.

8.2.7 Tools shall be cleaned initially and intermittently as necessary.

8.2.8 Preweld and interpass cleaning requirements shall be included in the WPS.

8.2.9 Stainless steel wire brushes shall be used in all instances where wire brushing is performed.

Low-current (10 ampere maximum), reverse-polarity, high-frequency arc cleaning (using manual, automatic, semi-automatic, or mechanized welding equipment) may be used to remove oxides from iron-, nickel-, and cobalt-base alloys.

MSFC Technical Standard EM30		
Title: Process Specification – Welding Aerospace Hardware	Document No.: MSFC-SPEC-3679	Revision: A
	Effective Date: October 22, 2018	Page 26 of 92

8.2.10 Fusion welding shall be started within 24 hrs. of initiating preweld cleaning, unless otherwise permitted by the responsible NASA Technical Authority.

8.2.10.1 Time between initiation of preweld cleaning and welding shall be documented in production build records.

8.2.11 In aluminum alloys, C-FSW joints will subsequently be intersected by fusion welds shall be cleaned by draw filing or scraping the abutting edges and scraping or wire brushing the crown and root surfaces of the weld land 0.5 in [12.7 mm] beyond the shoulder diameter.

8.2.12 All SR-FSW joints in aluminum alloys shall be cleaned by draw filing or scraping the abutting edges and mechanically abrading the crown and root surfaces of the weld land 0.5 in [12.7 mm] beyond the shoulder diameter.

Following the mechanical cleaning operations described in sections 8.2.11 and 8.2.12 above, solvent cleaning by wiping with lint-free clean cloth may be permitted.

8.2.13 The FSW full-penetration pass shall be started within 48 hrs. of initiating preweld joint cleaning unless otherwise permitted by the responsible NASA Technical Authority.

Tack welding is not considered a full-penetration weld.

8.2.14 EBW shall start within 40 hrs. after surface preparation has been completed, unless otherwise permitted by the responsible NASA Technical Authority, with the following exceptions:

8.2.14.1 EBW of aluminum alloys shall be performed within 8 hrs. after being cleaning.

8.2.14.2 If parts have been vacuum dried and stored in a sealed plastic film (other than polyethylene or nylon) bag purged with dry argon or gaseous nitrogen, the parts shall be welded together within 100 hrs. of cleaning.

8.2.15 Weld joints adjacent to brazed surfaces shall be cleaned in accordance with Appendix G to remove contamination from brazing operations.

8.2.16 All brazing alloy deposits shall be removed from the weld joint region that includes the joint and the area within 0.25 in [6.4 mm] of the joint, unless otherwise specified on the engineering drawing.

8.2.17 When welding precision-cleaned hardware, all welding of assemblies for precision-cleaned systems (including tube preparation) shall meet the requirements of MPCV 7016.

8.2.18 Plugs used for friction plug welding and the material to be plug welded shall be cleaned by abrasion to remove the oxide layer, followed by solvent cleaning within 8 hrs. of plug welding.

8.3 Preweld Joint Fit-up

8.3.1 After the parts have been mated, positioned and tacked for the welding operation, the joint shall be verified for compliance with the preweld and postweld dimensional requirements of Appendix B of this process specification.

8.3.2 Preweld joint gap requirements for specific materials and processes shall meet the requirements listed in Appendix B.

8.3.3 The interrelationship of mismatch, joint gap, peaking, and pin tool offset shall be shown by engineering analysis or test to assure that positive margins of safety exist for FSW.

CHECK THE MASTER LIST – VERIFY THAT THIS IS CORRECT VERSION BEFORE USE

MSFC Technical Standard EM30		
Title: Process Specification – Welding Aerospace Hardware	Document No.: MSFC-SPEC-3679	Revision: A
	Effective Date: October 22, 2018	Page 27 of 92

8.4 Weld Start and Run-Off Tabs

8.4.1 Weld start and run-off tabs (when used) shall be of the same alloy as the detail parts being welded.

8.4.2 Weld start and run-off tabs shall be cleaned in the same manner as the parts.

8.4.3 Tabs shall be integral with the part, being either machined in, welded with the same filler metal, or rigidly attached to the part pieces before assembly.

8.4.4 Length of weld start and run-off tabs shall be established, based on the confidence panel test results.

8.4.5 Use of weld start and run-off tabs shall be included in the WPS.

8.5 Laser and Electron Beam-to-Joint Alignment

8.5.1 Flat and Circular Welds

8.5.1.1 Before welding every weld joint of every production run, the entire length of the joint shall be leveled to within ± 0.005 in [± 0.127 mm] using a calibrated dial indicator.

8.5.1.2 The assumed centerline of the beam shall be aligned within 30 min of the gun angle defined in the approved weld parameter, as determined using a calibrated inclinometer in conjunction with a surface at a known reference angle to the joint faces.

8.5.2 Circumferential Welds

8.5.2.1 Before welding every weld joint of every production run, the axis of the assembly shall be leveled, using a calibrated dial indicator to within ± 0.005 in [± 0.127 mm] in relation to reference surfaces for weld joint faces perpendicular to the axis.

8.5.2.2 For off-axis joints, the assumed centerline of the beam shall be aligned within 30 min of the gun angle defined in the approved weld parameter, using a calibrated inclinometer in conjunction with a surface at a known reference angle to the joint faces.

MSFC Technical Standard EM30		
Title: Process Specification – Welding Aerospace Hardware	Document No.: MSFC-SPEC-3679	Revision: A
	Effective Date: October 22, 2018	Page 28 of 92

9.0 PRODUCTION WELDING

9.1 Equipment Operational Readiness Check

A welding equipment operational readiness check shall be made immediately before a production weld to verify that the equipment is operating properly.

An equipment checklist may be used to ensure equipment performance. Items such as pintoole part and serial number(s) (FSW), torch setup (fusion), air pressure, water pressure, shield gas flow, and other factors affecting equipment performance may be verified before weld initiation.

9.2 Temperature Control.

9.2.1 Preheat, interpass, and postheat temperatures shall be controlled so as not to degrade the properties of the material being welded.

9.2.2 These parameters shall be recorded in the applicable WPS.

9.3 Tack Welding

9.3.1 Tack welding shall be allowed, provided they are fully consumed by the final weldment.

9.3.2 After the final weldment is completed, the tack areas shall be inspected to the requirements of the finished weld.

9.3.3 Tack welding parameters shall be included in the WPS and used to generate PQR data.

Tack welding parameters are not essential variables.

9.3.4 Aluminum alloy joints to be FSW shall be tacked using FSW unless authorized by the responsible NASA Technical Authority.

Other tacking methods may be used provided requirements 9.3.1, 9.3.2 and 9.3.3 are met.

9.3.5 A tack weld made with EBW or LBW shall be made with a substantially reduced power density from the certified full-penetration pass, up to and including the full length of the weld.

A full-penetration tacking pass using certified parameters may be used.

9.3.5.1 If a full-penetration tacking pass using certified parameters is used, it shall not exceed 10 percent of the weld joint length for EBW.

9.3.5.2 If a full-penetration tacking pass using certified parameters is used, it shall terminate in the weld start and run-off tabs when applicable.

9.4 Welding Techniques

9.4.1 Square groove welds shall be completely penetrated from one side (Figure 1A).

MSFC Technical Standard EM30		
Title: Process Specification – Welding Aerospace Hardware	Document No.: MSFC-SPEC-3679	Revision: A
	Effective Date: October 22, 2018	Page 29 of 92

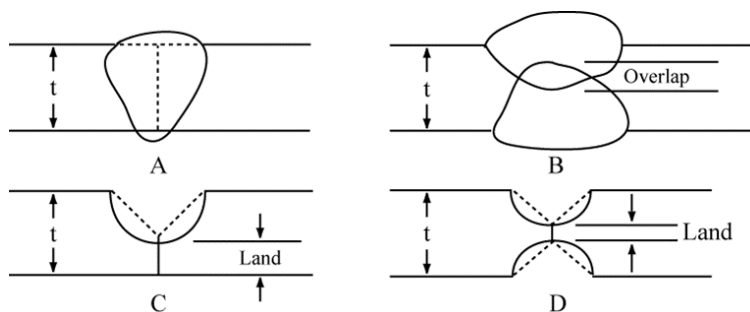

Figure 1. Welding Techniques

9.4.2 Partial-penetration groove welds shall be used only for Class C joints, unless approved by the responsible NASA Technical Authority.

9.4.3 Two-sided welding of butt joints (Figure 1B) shall only be allowed under the following conditions:

9.4.3.1 The weld shall be performed in a prepared groove joint (Figure 1C and Figure 1D), where it can be verified the initial pass consumed the entire abutting edge.

9.4.3.2 Partial-penetration welds from one side shall be machined into the penetration root to sound metal before completing the next pass.

9.4.4 At a minimum, visual inspection shall be used to ensure penetration.

9.5 Welding Procedure

9.5.1 A specific WPS for each weld shall be required for all production welds in accordance with the requirements of section 7.2.1.

9.5.2 Procedure Departure

9.5.2.1 Any departure from the qualified WPS during production welding shall require withholding of the component for MRB disposition, except as noted in section 5.1.4.

9.5.2.2 MRB records shall be maintained as temporary records per section 11.3.7.

9.5.2.3 The cause for departure shall be determined and corrective action taken before further production welding.

9.5.3 Cosmetic weld bead / passes shall only be allowed if included in a qualified WPS.

9.5.4 After welding, the EBW vacuum chamber shall not be vented until the component has cooled to a temperature below its oxidizing temperature, as specified in the qualified WPS.

9.5.5 SR-FSW shall be welded with the pin tool offset toward the retreating side of the joint in accordance with Appendix B.

MSFC Technical Standard EM30		
Title: Process Specification – Welding Aerospace Hardware	Document No.: MSFC-SPEC-3679	Revision: A
	Effective Date: October 22, 2018	Page 30 of 92

10.0 POSTWELD OPERATION

10.1 The Weldment

Each completed weldment (both face and root sides) and the adjacent base metal for a minimum 0.5 in [12.5 mm] on either side of the weld shall be inspected to ensure compliance with the requirements of sections 10.2, 10.3, and 10.6 as dictated by the class of the weld, unless approved by the responsible NASA Technical Authority.

10.2 General Workmanship Requirements

Uniform appearance of weld deposits, buildup, and root reinforcement shall be verified by visual confirmation.

10.2.1 The face and root sides shall be free of surface cracks, crater cracks, other defects open to the surface, and oxide scale.

Visual inspection of the root surface of C-FSW may be omitted if etch and dye penetrant inspection are performed.

10.2.2 The weld deposits shall be free of open voids or unfused overlapping folds.

10.2.3 For fusion welds the edge of the weld deposit shall blend smoothly into the base metal without unfused overlaps or undercuts.

10.2.4 Titanium alloy welds and adjacent base metal shall meet the color requirements of AWS G2.4/G2.4M.

With the exception of titanium alloys, discoloration caused by vapor deposition during EBW may be acceptable.

10.2.5 The surface of FSW shall be free of galling, tears, or blisters.

10.2.6 By-products of the welding process, such as weld-spatter, oxide scale, soot, flash, or other by-products, shall be removed from the welded component.

10.3 Dimensional Requirements

10.3.1 Welded Butt Joints

10.3.1.1 Welded butt joints shall have 100% penetration.

10.3.1.2 Welded butt joints shall meet the geometrical requirements in Appendix C.

10.3.1.3 The root bead width in fusion welds shall not exceed the maximum weld width specified in Appendix C.

10.3.1.4 The allowable postweld mismatch (Figure 2) shall not exceed the values specified in Appendix B.

10.3.1.5 The allowable postweld peaking (Figure 2) of the welded joint and adjacent base metal shall not exceed the values in Appendix B.

10.3.1.6 A standard template or other calibrated electronic measurement device having specified reference points shall be used for determination of peaking and mismatch.

MSFC Technical Standard EM30		
Title: Process Specification – Welding Aerospace Hardware	Document No.: MSFC-SPEC-3679	Revision: A
	Effective Date: October 22, 2018	Page 31 of 92

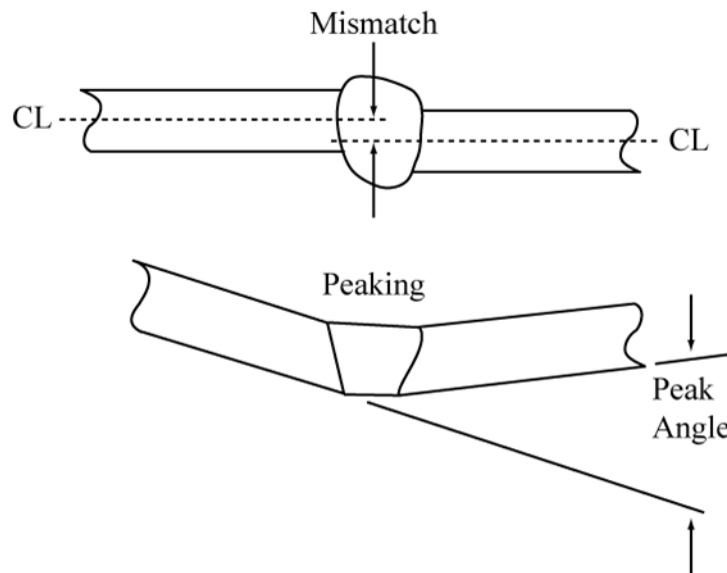

Figure 2. Mismatch and Peaking

The combined effect of mismatch and peaking on the efficiency of the weld joint is such that one can be increased if the other is decreased. A limited amount of mismatch and peaking greater than the values in Appendix B can be tolerated if it can be shown by engineering analysis or test that positive margins of safety exist.

10.3.2 Weld Reinforcement Removal

10.3.2.1 Weld reinforcement, both face side and root side, shall remain, unless specified by the engineering drawing.

The weld bead reinforcement may also be removed to eliminate defects occurring in the outer zones of the reinforcement unless otherwise specified on the engineering drawing.

10.3.2.2 For fusion welds, reinforcement removal shall not thin the weld or base metal below drawing dimensional requirements.

10.3.2.3 When flush contour is required by the welding symbol, weld reinforcement shall not exceed 0.015 in [0.4 mm].

10.3.2.4 Metal removal shall be such that the mechanically reworked area blends smoothly, e.g., 0.125 in [3.2 mm] radius, with adjacent material without abrupt sectional changes.

10.3.2.5 Surface roughness, after reinforcement removal, shall not exceed 250 μin [0.006 mm] or the specification on the drawing.

10.3.2.6 Grinding of base metal shall not be done when wall thickness cannot be verified after grinding.

MSFC Technical Standard EM30		
Title: Process Specification – Welding Aerospace Hardware	Document No.: MSFC-SPEC-3679	Revision: A
	Effective Date: October 22, 2018	Page 32 of 92

10.3.2.7 Flash material in solid-state welds shall be removed.

- (1) Techniques to remove flash, metal slivers, anvil marks on C-FSW and other sharp or raised metal shall not interfere with postweld NDE inspections.
- (2) Material thickness shall not be reduced below the allowed underthickness specified in Appendix C.

10.3.2.8 Weldments that are machined, ground, or otherwise mechanically worked causing disruption or smearing of the material surface shall be etched to remove the masking material before penetrant application.

10.3.3 Fillet Welds

10.3.3.1 The minimum acceptable fillet size shall be that specified by the engineering drawing.

10.3.3.2 The maximum acceptable fillet size shall be the size specified plus 50% or 0.188 in [4.8 mm], whichever is less.

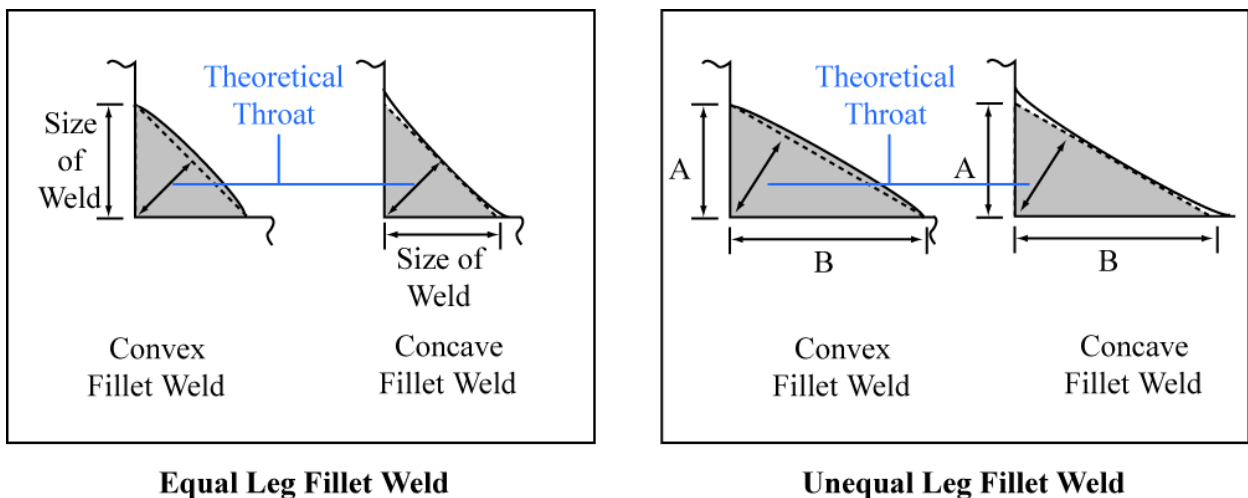

Figure 3. Fillet Weld Throats

When not specified on a drawing, the fillet sizes for superalloys given in Appendix C may be used.

For equal leg fillet welds, the fillet size is equal to the leg length of the largest inscribed right isosceles triangle.

For unequal leg fillet welds, the fillet size is the leg length of the largest right triangle that can be inscribed within the fillet weld cross section (A and B in Figure 3).

10.3.3.3 Fillet weld fusion of the root (Figure 4) shall have a minimum of 10% penetration of base metal thickness of the thinnest member of the root of the joint as determined by evaluation of transverse sections taken from the qualification welds.

MSFC Technical Standard EM30		
Title: Process Specification – Welding Aerospace Hardware	Document No.: MSFC-SPEC-3679	Revision: A
	Effective Date: October 22, 2018	Page 33 of 92

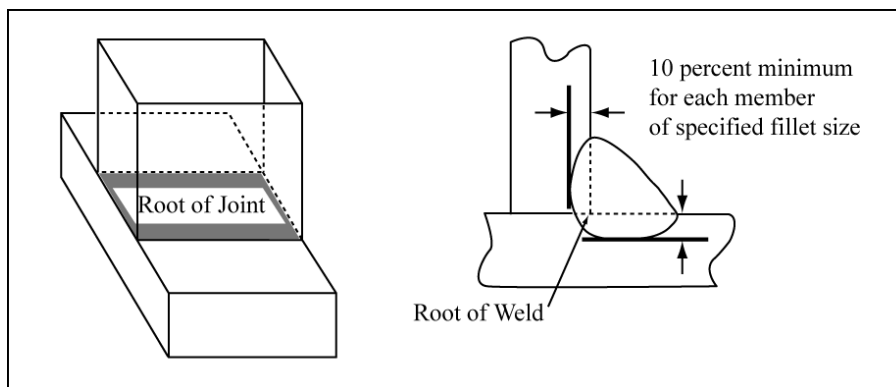

Figure 4. Fillet Welds

10.3.3.4 Fillet welds terminating at corners with un-welded joints shall have the fillet continued around the corner into the un-welded joint is a minimum of 0.125 in [3.2 mm], and a maximum of 0.5 in [12.5 mm].

10.3.3.5 Toes of fillet welds shall blend smoothly with adjacent base metal.

10.3.3.6 The root of the weld shall penetrate to the extent that the actual throat dimension exceeds the theoretical throat dimension as shown in Figure 3.

10.4 Weldment Straightening

10.4.1 Straightening of welds and adjacent base metal that have been deformed by the welding operation shall be allowed only in accordance with a procedure approved by the responsible NASA Technical Authority.

10.4.2 The straightening procedure shall be verified on test coupons using NDE, destructive testing, and metallurgical examination to verify the process used for straightening does not degrade the weld and surrounding material below the specified design requirements.

10.4.3 The straightening procedure shall be documented on the WPS.

10.4.4 Weldment straightening shall not be performed on welds failing to meet the acceptance criteria described in section 10.6 of this process specification.

10.4.5 Following weldment straightening, the weld and adjacent base metal shall be inspected in accordance with section 10.1 of this process specification.

10.4.6 Weldments with defects revealed by straightening operations shall not be acceptable.

10.4.7 Peening or Planishing

10.4.7.1 When specified on the engineering drawing, peening or planishing shall be performed in accordance with a qualified WPS that was established based on welded and peened or planished qualification test samples that simulate the material type and joint configurations to be used on the production component in accordance with section 7.3.2 of this process specification.

10.4.7.2 Peening or planishing shall not be performed on cover passes or on welds less than 0.090 in [2.3 mm] in thickness.

MSFC Technical Standard EM30		
Title: Process Specification – Welding Aerospace Hardware	Document No.: MSFC-SPEC-3679	Revision: A
	Effective Date: October 22, 2018	Page 34 of 92

10.4.7.3 When interpass inspections are required by the engineering drawing, they shall be performed before and after peening.

10.5 Postweld Heat Treatment Requirements

10.5.1 Weldments subject to heat treatment operations shall be inspected before and after heat treatment in accordance with the quality requirements listed in section 10.6 of this process specification.

10.5.2 Postweld heat treatment processing shall be as identified on the engineering drawing and the heat treatment included in the WPS.

10.6 Weldment Quality Requirements

It is recommended a workmanship standard be developed for interpretation of acceptance criteria when needed.

10.6.1 Surface Requirements

Surface requirements shall apply to the final weld condition, to the crown side of all welds, and to the root side of full-penetration welds.

10.6.1.1 The surface acceptance requirements shall be as listed in Appendix D.

10.6.1.2 For penetrant inspection of unshaved VPPA weld root beads, transverse indications confined to the width of the weld bead are acceptable except at weld intersections. Transverse indications extending into the parent material or the toe radius are to be rejected regardless of length.

10.6.2 Volumetric Requirements

10.6.2.1 The volumetric acceptance requirements shall be as listed in Appendix D.

10.6.2.2 The radiographic linear indication at the root of the weld (Figure 4), which is inherent in the design of fillet welds, shall not be considered a crack.

Workmanship standards should be developed to facilitate interpretation of fillet weld radiographic linear indications.

10.7 Repair Welding

10.7.1 Additional welding operations shall be permitted to correct any unacceptable defect established in accordance with section 10.6 of this process specification, provided the repair or rework welding parameters and procedures are specified in a qualified repair WPS and the repair or rework is contained within the original weld zone.

10.7.2 Complete records of the repair or rework welding operation, including identification of the repaired or reworked weldment, type of defect, and location of the repair or rework weld, shall be retained in accordance with NPR 1441.1.

10.7.3 Visual re-inspection and NDE of all repair weld areas shall be performed using the same methods and requirements as used on the original weld.

MSFC Technical Standard EM30		
Title: Process Specification – Welding Aerospace Hardware	Document No.: MSFC-SPEC-3679	Revision: A
	Effective Date: October 22, 2018	Page 35 of 92

10.7.4 All 2195 fusion weld repairs shall be planished to recover 70% of the shrinkage induced during heat repair operations using qualified planishing procedures.

10.8 Material Review Board

MRB disposition shall be required when any one of the following conditions exists:

10.8.1 When more than two weld repair attempts have been performed at the same location on materials that are heat sensitive.

10.8.2 When more than five weld repair attempts have been performed at the same location on materials that are not heat sensitive.

10.8.3 When the wrong filler metal has been used.

10.8.4 When a repair weld is required after the weldment has been postweld heat treated.

10.8.5 When a repair weld is required after final machining has been completed.

10.8.6 When the repair extends outside the original weld zone (fusion zone and HAZ).

10.8.7 When a weldment has been direct aged, i.e., aged only without intermediate solution heat treatment, unless authorized by the NASA Technical Authority.

10.8.8 When a weldment has been made with parameters outside the qualified WPS range.

10.8.9 All repairs of defective plug welds.

10.8.10 Weld repairs following proof or leak test.

MSFC Technical Standard EM30		
Title: Process Specification – Welding Aerospace Hardware	Document No.: MSFC-SPEC-3679	Revision: A
	Effective Date: October 22, 2018	Page 36 of 92

11.0 VERIFICATION

11.1 General

11.1.1 The supplier shall be responsible for the performance and evaluation of all visual inspection and NDE as required by this process specification.

11.1.2 The supplier shall use visual inspection and NDE facilities and services approved by the procuring agency or through a vendor selection process approved by the procuring agency unless otherwise specified.

The procuring agency or its designated representative reserves the right to perform any or all of the visual inspections and NDE required to assure the end item conforms to the prescribed requirements.

11.1.3 NDE procedures to be used in inspection for weldment volumetric and surface quality requirements shall be validated as being capable of detecting the acceptance criteria described in Appendix D of this process specification before inspection of the first production weld.

11.1.4 Personnel performing visual weld inspections shall be certified to AWS QC1 or equivalent.

Additional information for certifying personnel to perform visual inspection and NDE of welds may be found in MWI 3410.5.

11.1.5 Personnel performing NDE weld inspections shall be certified in accordance with NAS 410.

11.1.6 For inspection of fracture-critical welds, personnel performing NDE shall be, at a minimum, certified Level II in accordance with NAS 410.

11.1.7 Dimensional inspection of joint fit-up quality requirements of FSW shall be performed immediately prior to performing the full penetration weld per section 8.3 of this specification.

11.2 Postweld Inspection

11.2.1 The supplier shall certify that each semi-automatic, mechanized, and automatic production weld was made within the range of operating parameters established in the qualified WPS and as allowed per section 7.2.9.

11.2.2 Visual Inspection

11.2.2.1 The weld metal and adjacent base metal for a minimum distance of 0.5 in [12.5 mm] on either side of the weld interface shall be visually inspected to ensure compliance for all weld classes with the general workmanship requirements of section 10.2.

11.2.2.2 The weld shall be in the as-welded condition for the initial visual inspection, except that surface smut and loose oxide have been removed in such a way that does not smear metal or change the quality of the weld.

11.2.2.3 Titanium weld deposit and heat-affected zone discoloration shall be in accordance with the accept/reject criteria requirements within AWS G2.4/G2.4M color chart.

11.2.2.4 For FSW scratches and tooling marks shall not be cause for rejection, provided they meet surface finish requirements.

MSFC Technical Standard EM30		
Title: Process Specification – Welding Aerospace Hardware	Document No.: MSFC-SPEC-3679	Revision: A
	Effective Date: October 22, 2018	Page 37 of 92

11.2.2.5 Indications attributed to anvil joint gaps or anvil gouges for C-FSW and FPPW shall not be cause for rejection.

11.2.3 Dimensional Inspection

11.2.3.1 Dimensional inspection shall be performed on weldments of all weld classes to assure compliance with the requirements of the design drawing for all weld classes and requirements in section 10.3 of this process specification.

11.2.3.2 For FSW, within 1.5 in [38.1 mm] of an intersection weld minimal thickness shall be equal to or greater than the minimum drawing thickness.

11.2.4 Volumetric Quality NDE

NDE methods shall be performed, as required by engineering drawing, to assure that the weldment meets quality requirements for Class A and Class B welds, as applicable.

11.2.4.1 NDE procedures and techniques shall be qualified in accordance with NASA-STD-5009, and with guidelines from MIL-HDBK-1823, for detectability of critical defect.

11.2.4.2 When reliability of inspection and critical flaw detection so dictate, redundant and/or complementing inspection techniques and procedures shall be used.

Volumetric inspections may be waived for non-fracture-critical fillet welds when the specified fillet size is increased 25% for Class A aluminum welds and 30% for Class A steel, corrosion- or heat-resistant alloys, or 20% for Class B aluminum welds and 25% for Class B steel, corrosion- and heat-resistant alloys, given prior approval by the responsible NASA Technical Authority.

11.2.5 Surface Quality NDE

11.2.5.1 NDE methods shall be performed to assure compliance with the surface quality requirements as required by engineering drawing and those in section 10.6.1 and Appendix D of this process specification for Class A and Class B welds.

11.2.5.2 NDE procedures shall be qualified in accordance with NASA-STD-5009 and with guidelines from MIL-HDBK-1823 for detectability of critical defect.

11.2.5.3 When reliability of inspection and critical flaw detection so dictate, redundant and/or complementing inspection techniques and procedures shall be used.

11.2.5.4 The supplier shall verify weldments subjected to mechanical working have been etched to remove smeared metal before penetrant application.

11.3 Records

11.3.1 Records of a continuous audit of weldment production quality (including validation and qualification of NDE procedures and techniques) shall be submitted and maintained in accordance with contract requirements.

11.3.2 Resulting records shall include, but not be limited to, the location of repairs, type of defects repaired, procedures used, inches of repair per total inches of weld, and number of repair attempts in any one location.

MSFC Technical Standard EM30		
Title: Process Specification – Welding Aerospace Hardware	Document No.: MSFC-SPEC-3679	Revision: A
	Effective Date: October 22, 2018	Page 38 of 92

11.3.3 The probability of detection (POD) capability documentation shall be retained as a temporary record by the developing organization per section 11.3.7.

11.3.4 These records shall be accounted on a quarterly basis, with such accounting made available to the responsible NASA Technical Authority.

11.3.5 Production build records, including visual inspection and NDE test records, shall be maintained and made available upon request by the procuring agency or its designated representative.

11.3.6 Deviations from requirements in this specification shall be documented by tailoring, as defined in section 1.4 and maintained as temporary records as defined in section 11.3.7 by the procuring agency or its designated representative.

11.3.7 The Records Retention Schedule in NPR 1441.1 shall be flowed down through the contract.

MSFC Technical Standard EM30		
Title: Process Specification – Welding Aerospace Hardware	Document No.: MSFC-SPEC-3679	Revision: A
	Effective Date: October 22, 2018	Page 39 of 92

Appendix A Procedure Qualification Weld Strength Requirements

A.1 PURPOSE AND/OR SCOPE

This appendix contains procedure qualification weld strength requirements.

A.2 BUTT WELD ULTIMATE TENSILE STRENGTH REQUIREMENTS (ALUMINUM ALLOYS)

The butt weld ultimate tensile strength requirements for aluminum alloys provided in Table III thru Table VI shall be adjusted by the responsible NASA Technical Authority if product forms, temper, or the base metal plate gauge cross section, i.e., $t/6$, used to qualify the weld procedure is other than thin plate.

A.3 PROCEDURE QUALIFICATION TENSILE PROPERTIES

The values listed in this appendix for procedure qualification tensile properties are for qualification only and shall not be used for design purposes.

A.4 ALTERNATIVE ULTIMATE TENSILE STRENGTH REQUIREMENTS

Alternative ultimate tensile strength requirements used for weld procedure qualification, shall be approved by the responsible NASA Technical Authority.

This may include alloy combinations not listed in Table III thru Table VI.

A.5 JOINT EFFICIENCY

If joint efficiency is to be used to establish weld strength requirements then parent tensile specimens shall be extracted from the product form panel in the same grain orientation as the welded samples.

MSFC Technical Standard EM30		
Title: Process Specification – Welding Aerospace Hardware	Document No.: MSFC-SPEC-3679	Revision: A
	Effective Date: October 22, 2018	Page 40 of 92

A.6 PROCEDURE QUALIFICATION WELD STRENGTH REQUIREMENTS FOR ALUMINUM ALLOYS

Table III. GTAW Process Butt Weld Ultimate Tensile Strength Requirements

Alloy	Base Metal Temper	Base Metal Thickness (t), in [mm]	Room Temperature		Cryogenic LO ₂	Cryogenic LH ₂
			Min., ksi [MPa]	Avg, ksi [MPa]	Min. ksi [MPa]	Min., ksi [MPa]
2014	T6	<0.125 [<3]	43 [297]	45.5 [314]		
		0.125 ≤ t ≤ 0.25 [3 ≤ t ≤ 6]	40 [276]	42.5 [293]		
		>0.25 [>6]	38 [262]	40.5 [279]		
2195	T8M4	≤0.25 [≤6]	40 [276]	42 [290]	48 [331]	52 [359]
		0.251 < t ≤ 0.65 [6.4 < t ≤ 16.5]	38 [262]	40 [276]	45.6 [314]	49.4 [341]
2219	T81	All	38 [262]	40 [276]		
	T87	All	38 [262]	40 [276]	45.6 [314]	49.4 [341]
	T3X ¹	≤0.25 [≤6]	42 [290]	44 [303]		
		0.25 < t ≤ 0.5 [6 < t ≤ 13]	40 [276]	42 [290]		
		0.5 < t ≤ 0.75 [13 < t ≤ 19]	42 [290]	44 [303]		
		0.75 < t ≤ 1 [19 < t ≤ 25]	43 [297]	45 [310]		
		1 < t ≤ 1.25 [25 < t ≤ 32]	44 [303]	46 [317]		
	1.25 < t ≤ 1.5 [32 < t ≤ 38]	45 [310]	47 [324]			
O/T8X	0.125 [3]	19 [131]	21 [145]			
5052	All	All	25 [172]	28 [193]		
5456	All	All	42 [290]	44 [303]		
6061	T4	All	24 [166]	27 [186]		
	T6	All	24 [166]	27 [186]		

¹Applicable to tempers that require an aging cycle of 350 (±10) °F [177 (±5) °C] for 18 hrs. in accordance with SAE AMS 2770.

CHECK THE MASTER LIST – VERIFY THAT THIS IS CORRECT VERSION BEFORE USE

MSFC Technical Standard EM30		
Title: Process Specification – Welding Aerospace Hardware	Document No.: MSFC-SPEC-3679	Revision: A
	Effective Date: October 22, 2018	Page 41 of 92

Table IV. VPPA Process Butt Weld Ultimate Tensile Strength Requirements

Alloy	Base Metal Temper	Base Metal Thickness (t), in [mm]	Room Temperature		Cryogenic LO ₂	Cryogenic LH ₂
			Min., ksi [MPa]	Avg., ksi [MPa]	Min., ksi [MPa]	Min., ksi [MPa]
2195	T8M4	≤ 0.25 [6]	40 [276]	42 [290]	48 [331]	52 [359]
		0.25 < t ≤ 0.65 [6.4 < t ≤ 16.5]	38 [262]	40 [276]	45.6 [314]	49.4 [341]
2219 ¹	T87	≤ 0.4 [10.2]	38 [262]	40 [276]	45.6 [314]	49.4 [341]
		0.4 < t ≤ 0.75 [10.2 < t ≤ 19.0]	36 [248]	39 [269]	43.2 [298]	46.8 [323]
		0.75 < t ≤ 1.1 [19.0 < t ≤ 27.9]	35 [241]	38 [262]	42 [290]	45.5 [314]
2219 ²	T87	≤ 0.33 [8.4]	38 [262]	40 [276]	45.6 [314]	49.4 [341]
		0.33 < t ≤ 0.360 [8.4 < t ≤ 9.1]	37 [255]	38.5 [265]	43.2 [298]	46.5 [321]
2195/2219	T8M4/T87	< 0.25 [6]	40 [276]	42 [290]	48 [331]	52 [359]
		0.25 < t ≤ 0.650 [6 < t ≤ 16.5]	38 [262]	40 [276]	45.6 [314]	49.4 [341]

¹Vertical Position

²Flat and 45° Positions.

Table V. FSW Process Butt Weld Ultimate Tensile Strength Requirements

Alloy	Base Metal Temper	Base Metal Thickness (t), in [mm]	Room Temperature		Cryogenic LO ₂	Cryogenic LH ₂
			Min., ksi [MPa]	Avg., ksi [MPa]	Min., ksi [MPa]	Min., ksi [MPa]
2014/2219	T6/T8X	≤ 0.25 [6]	46 [317]	48 [331]	57.6 [397]	62.4 [430]
2195	T8M4	0.25 < t ≤ 0.5 [6.4 < t ≤ 12.7]	57 [393]	59 [407]	71 [490]	82.6 [570]
2219/2219	T87	0.25 < t ≤ 0.5 [6.4 < t ≤ 12.7]	48 [331]	50 [345]	55.2 [381]	60 [414]
2195/2219	T8M4/T87	0.320 < t ≤ 0.65 [8.1 < t ≤ 16.5]	46 [317]	48 [331]	55.2 [381]	64.4 [444]
2219/2195	T87/T8M4	0.320 < t ≤ 0.65 [8.1 < t ≤ 16.5]	48 [331]	50 [345]	57.6 [397]	67.2 [463]

CHECK THE MASTER LIST – VERIFY THAT THIS IS CORRECT VERSION BEFORE USE

MSFC Technical Standard EM30		
Title: Process Specification – Welding Aerospace Hardware	Document No.: MSFC-SPEC-3679	Revision: A
	Effective Date: October 22, 2018	Page 42 of 92

Table VI. Close-out FPW in FSW Process Ultimate Tensile Strength Requirements

Alloy	Base Metal Temper	Base Metal Thickness (t), in [mm]	Room Temperature		Cryogenic LO ₂	Cryogenic LH ₂
			Min., ksi [MPa]	Avg., ksi [MPa]	Min., ksi [MPa]	Min., ksi [MPa]
2014/2219 ¹ /2219	T6/T851 ² /T8X	≤ 0.25 [6]	46 [317]	48 [331]	52.8 [364]	57.6 [397]
2195/2195 ¹ /2195	T8M4/T851 ² /T8M4	0.25 < T ≤ 0.320 [6.4 < T ≤ 8.1]	54 [372]	56 [386]	62 [427]	67.5 [465]
2195/2195 ¹ /2219	T8M4/T8M4 ² /T851, T8X or T6	0.32 [8.1]	45 [310]	47 [324]	52 [358]	56 [386]
2219/2195 ¹ /2195	T8X or T6/T851 ² /T8X	0.32 [8.1]	47 [324]	49 [338]	54 [372]	59 [408]

¹Denotes FPW material

²Denotes FPW temper

A.6.1 In relation to the GTAW process for 2219 (Table III), butt weld ultimate tensile strength requirements for tempers that require other postweld aging cycles shall be approved by the procuring agency.

A.6.2 Average shall be the arithmetic average of all values measured.

A.6.3 No single value shall be less than the minimum value specified.

A.7 PROCEDURE QUALIFICATION WELD STRENGTH REQUIREMENTS FOR SUPERALLOYS

A.7.1 Average shall be the arithmetic average of all values measured.

A.7.2 No single value shall be less than the minimum value specified.

CHECK THE MASTER LIST – VERIFY THAT THIS IS CORRECT VERSION BEFORE USE

MSFC Technical Standard EM30		
Title: Process Specification – Welding Aerospace Hardware	Document No.: MSFC-SPEC-3679	Revision: A
	Effective Date: October 22, 2018	Page 43 of 92

Table VII. Fusion Butt Weld Ultimate Tensile Strength Requirements for Superalloys

Alloy	Base Metal Temper	Postweld Age Cycle	Base Metal Thickness (t), in [mm]	Room Temperature	
				Min., ksi [Mpa]	Avg., ksi [MPa]
Inconel 718	STA ¹	As-Welded	≤0.25 [6]	120 [827]	125 [862]
Inconel 718	STA ¹	STA ¹ or DA	≤0.25 [6]	170 [1172]	175 [1207]
Inconel 718	Annealed ²	As-Welded	≤0.25 [6]	100 [689]	105 [724]
Inconel 718	Annealed ²	STA ¹ or DA	≤0.25 [6]	145 [1000]	150 [1034]
Inconel 625	Annealed ³	As-Welded	≤0.5 [12.5]	105 [724]	110 [758]
Haynes 188	Solution Treated	As-Welded	≤0.25 [6]	110 [758]	117 [807]

¹Annealed and aged in accordance with either standard practice, 1750 °F (954 °C), or 1950 °F (1066 °C) anneal followed by aging.

²Annealed in accordance with either standard practice, 1750 °F (954 °C), or 1950 °F (1066 °C).

³Annealed 1750 °F (954 °C).

Table VIII. Fusion Butt Weld Ultimate Tensile Strength Requirements for Titanium Alloys

Alloy	Base Metal Temper	Postweld Age Cycle	Base Metal Thickness (t), in [mm]	Room Temperature	
				Min., ksi [Mpa]	Avg., ksi [MPa]
Ti-6AL-4V ELI	Annealed	Stress relieved	≤ 0.25 [6]	130 [896]	138 [951]

Table IX. Fusion Butt Weld Ultimate Tensile Strength Requirements for Stainless Steel Alloys

Alloy	Base Metal Temper	Postweld Age Cycle	Base Metal Thickness (t), in [mm]	Room Temperature	
				Min., ksi [Mpa]	Avg., ksi [MPa]
304L	Annealed	As welded	≤0.5 [12.5]	65 [448]	68 [469]
316L	Annealed	As welded	≤0.5 [12.5]	67 [462]	69 [476]
321	Annealed	As welded	≤0.5 [12.5]	73 [503]	75 [517]
347	Annealed	As welded	≤0.5 [12.5]	72 [496]	74 [510]
21-6-9	Annealed	As welded	≤0.5 [12.5]	100 [689]	105 [724]

CHECK THE MASTER LIST – VERIFY THAT THIS IS CORRECT VERSION BEFORE USE

MSFC Technical Standard EM30		
Title: Process Specification – Welding Aerospace Hardware	Document No.: MSFC-SPEC-3679	Revision: A
	Effective Date: October 22, 2018	Page 44 of 92

Appendix B Weld Joint Dimensional Requirements

B.1 PURPOSE AND/OR SCOPE

The purpose of this appendix is to provide weld joint dimensional requirements.

B.2 FIT-UP REQUIREMENTS

Table X and Table XI present preweld and postweld joint fit-up requirements for various welding processes.

Values in Table X and Table XI may be changed with approval by the responsible NASA Technical Authority if positive margins of safety can be shown by engineering analysis or test data.

Table X. Preweld Joint Fit-up Requirements

Process	Mismatch, in [mm]	Peaking, degrees	Joint Gap, in [mm]	Pin Tool Offset
Fusion	As required to meet postweld requirements	As required to meet postweld requirements	N/A	N/A
EBW and LBW	10% of joint thickness or 0.01 [0.25], whichever is less, for thickness up to 0.25 [6.25] 10% of joint thickness or 0.03 [0.75], whichever is less, for thickness greater than 0.25 [6.25]	N/A	5% thickness up to 0.009 [0.22]	N/A
			10% thickness over 0.009 - 0.061 [0.22 - 1.52]	
			Not to exceed 0.01 [0.25] thickness over 0.061 - 1.49 [1.52 - 37.2]	
SR-FSW 0.200 < t < 0.327 [5.0 < t < 8.3]	0.040 [1]	2	0.030 [0.76]	0.05 [1.27] Minimum - 0.20X pin diameter
C-FSW 0.250 < t < 0.650 [6.36 < t < 16.5]	0.020 [0.508]	3	0.040 [1]	N/A

CHECK THE MASTER LIST – VERIFY THAT THIS IS CORRECT VERSION BEFORE
USE

MSFC Technical Standard EM30		
Title: Process Specification – Welding Aerospace Hardware	Document No.: MSFC-SPEC-3679	Revision: A
	Effective Date: October 22, 2018	Page 45 of 92

Table XI. Postweld Joint Fit-up Requirements

Process	Base Metals	Mismatch, in [mm]	Peaking, in [mm]
Fusion	Steels, corrosion- and heat-resistant alloys	0.06 [1.5] or 20% of the thinnest member, whichever is less	5 deg maximum unless at a weld intersection, then 2 deg for 6 [15.2] adjacent to intersection
	Aluminum alloys	0.02 [0.508] for thickness of 0.2 [5.08] or less	5 deg maximum unless at a weld intersection, then 2 deg for 6 [15.2] adjacent to intersection
		For thickness greater than 0.2 [5.08], maximum 0.04 [10.16] or 10% of thinnest member, whichever is less	
	Titanium alloys	0.06 [1.5] or 20% of the thinnest member, whichever is less for material thickness of 0.5 [12.5] or less	5 deg maximum unless at a weld intersection, then 2 deg for 6 [15.2] adjacent to intersection
0.120 [3.0] or 10% of material thickness, whichever is less, for material thickness greater than 0.5 [12.5]			
FSW	Aluminum alloys	N/A	N/A

CHECK THE MASTER LIST – VERIFY THAT THIS IS CORRECT VERSION BEFORE
USE

MSFC Technical Standard EM30		
Title: Process Specification – Welding Aerospace Hardware	Document No.: MSFC-SPEC-3679	Revision: A
	Effective Date: October 22, 2018	Page 46 of 92

Appendix C Weld Nugget Dimensional Requirements

C.1 PURPOSE AND/OR SCOPE

The purpose of this appendix is to provide weld nugget dimensional requirements for various welding techniques and materials.

C.2 FUSION

Table XII and Figure 5 provide fusion weld nugget dimensional requirements.

Table XII. Dimensional Requirements for Butt Welds – Fusion¹

Base Metal	Thickness, in [mm]	d-Min., in [mm]	As-Welded Reinforcement (R and R') Minimum		Weld Width (W' and W'') Maximum	
			R, in [mm]	R', in [mm]	Multipass, Beveled Joint, and Torch Oscillated, in [mm]	Single Pass, Square Butt, in [mm]
Aluminum Alloys	< 0.125 [3]	0.020 [0.508]	0.005 [0.127]	0.015 [0.381]	5t	0.375 [9.5] or 5t, whichever is smaller
	0.125 - 0.25 [3 - 6]	0.05 [1.27]	0.005 [0.127]	0.015 [0.381]	1t + 0.4 [10.2]	1t + 0.25 [6]
	> 0.25 [6]	0.06 [1.524]	0.005 [0.127]	0.015 [0.381]	As required by design	As required by joint design
2195	0.125 - 0.25 [3 - 6]	0.05 [1.27]	0.04 [1]	0.04 [1]	1t + 0.4 [10.2]	1t + 0.25 [6]
	> 0.25 [6]	0.06 [1.524]	0.04 [1]	0.04 [1]	0.75t + 0.45 [11.4]	0.5t + 0.45 [11.4]

¹Reference Figure 5

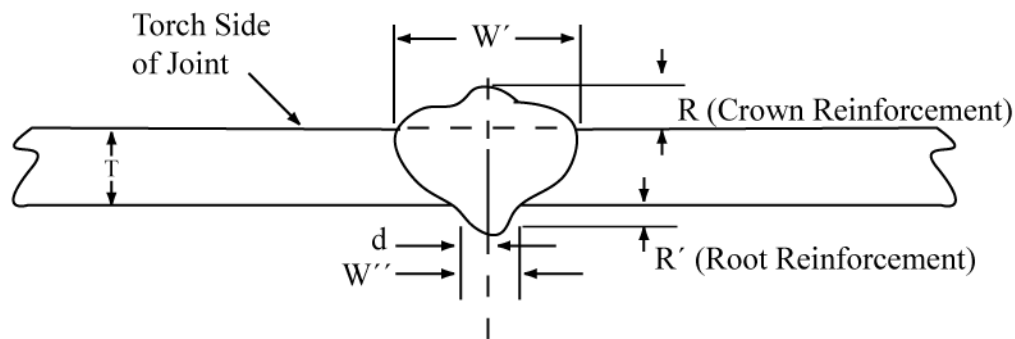

d = distance from original joint centerline to edge of root reinforcement. Examine in the as-welded condition to ensure that the original joint centerline can be detected on the root side of the joint.

Figure 5. Aluminum Fusion Butt Weld

CHECK THE MASTER LIST – VERIFY THAT THIS IS CORRECT VERSION BEFORE
USE

MSFC Technical Standard EM30		
Title: Process Specification – Welding Aerospace Hardware	Document No.: MSFC-SPEC-3679	Revision: A
	Effective Date: October 22, 2018	Page 47 of 92

C.3 ELECTRON BEAM WELDING

Figure 6 thru Figure 9 illustrate weld nugget dimensional requirements for EBW Butt Joints.

C.3.1 The weld offset shall not exceed $0.2D$ or 0.06 in [1.5 mm], whichever is less, where D is the minimum required depth of fusion.

C.3.2 Offset shall be measured on the face side (beam impinging side) of the joint at a distance of 0.15 in ± 0.06 [3.8 mm ± 1.5] from the edge of the fusion zone on either side of the weld.

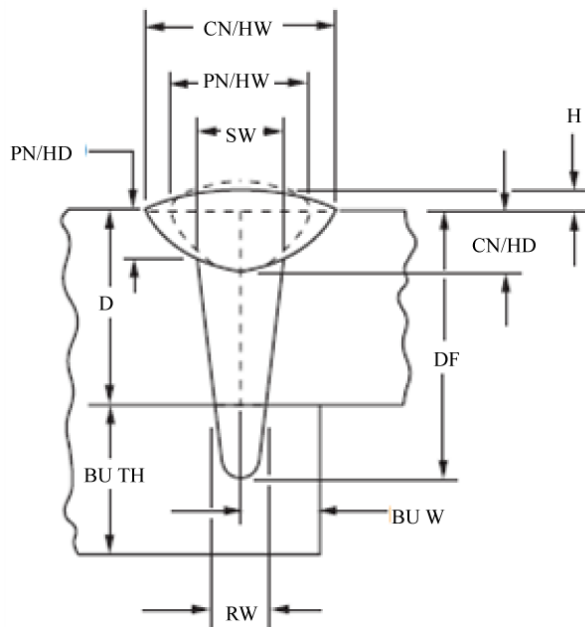

- ① D = actual joint depth
 CN/HW = cosmetic nailhead width
 PN/HW = penetration nailhead width
 CN/HD = cosmetic nailhead depth
 PN/HD = penetration nailhead depth
 SW = stem width
- ② RW = root width
 BU W = backup width
 BU TH = backup thickness
 H = reinforcement height (0.090 in (0.228 cm) max)
 DF = depth of fusion
- ① = depth of joint or required depth of joint penetration, as applicable
- ② = root width, measured at a depth corresponding to the depth of the joint or the required depth of joint penetration, whichever is applicable

Figure 6. EBW Butt Weld

MSFC Technical Standard EM30		
Title: Process Specification – Welding Aerospace Hardware	Document No.: MSFC-SPEC-3679	Revision: A
	Effective Date: October 22, 2018	Page 48 of 92

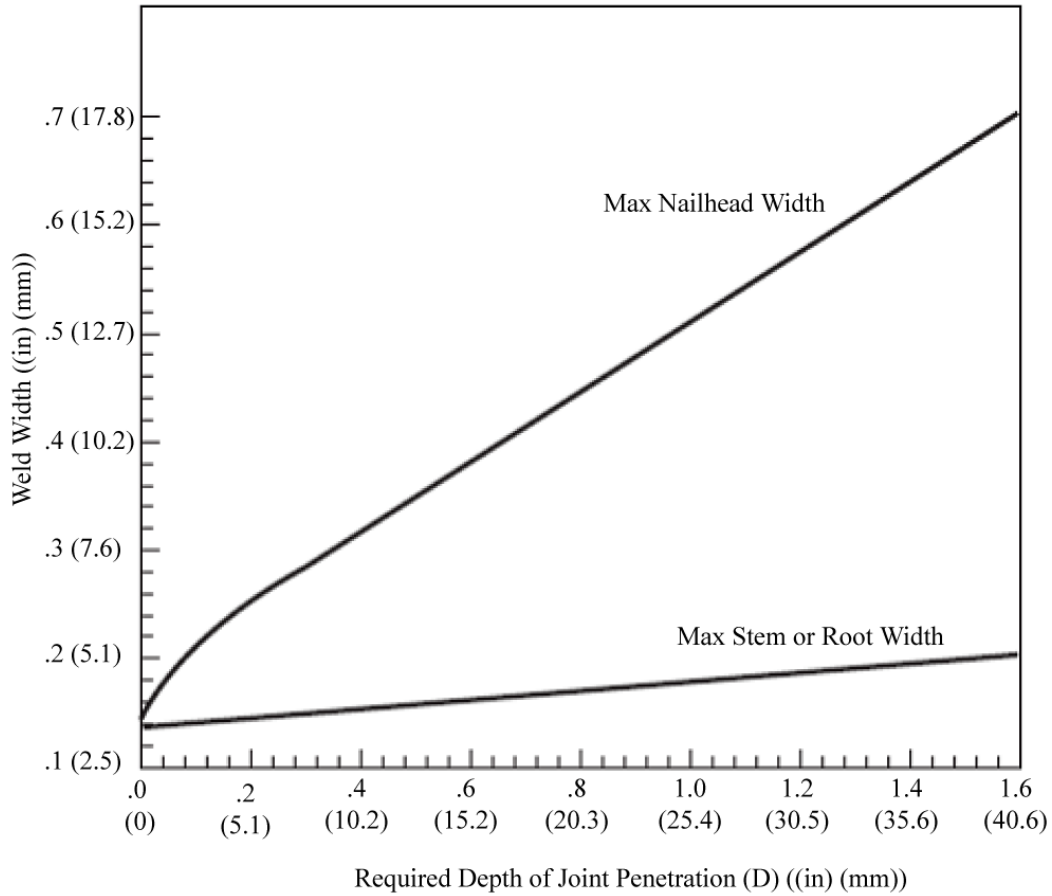

Note: For $D > 1.6$ in (> 41 mm):
(a) Max stem width shall be 0.2 in (5 mm)
(b) Max root width shall be 0.2 in (5 mm)
(c) Max nailhead width shall be 0.7 in (18 mm)

Figure 7. EBW Max Weld Crown and Root Widths for Penetration Depths (D) ≤ 1.6 in [41 mm]

MSFC Technical Standard EM30		
Title: Process Specification – Welding Aerospace Hardware	Document No.: MSFC-SPEC-3679	Revision: A
	Effective Date: October 22, 2018	Page 49 of 92

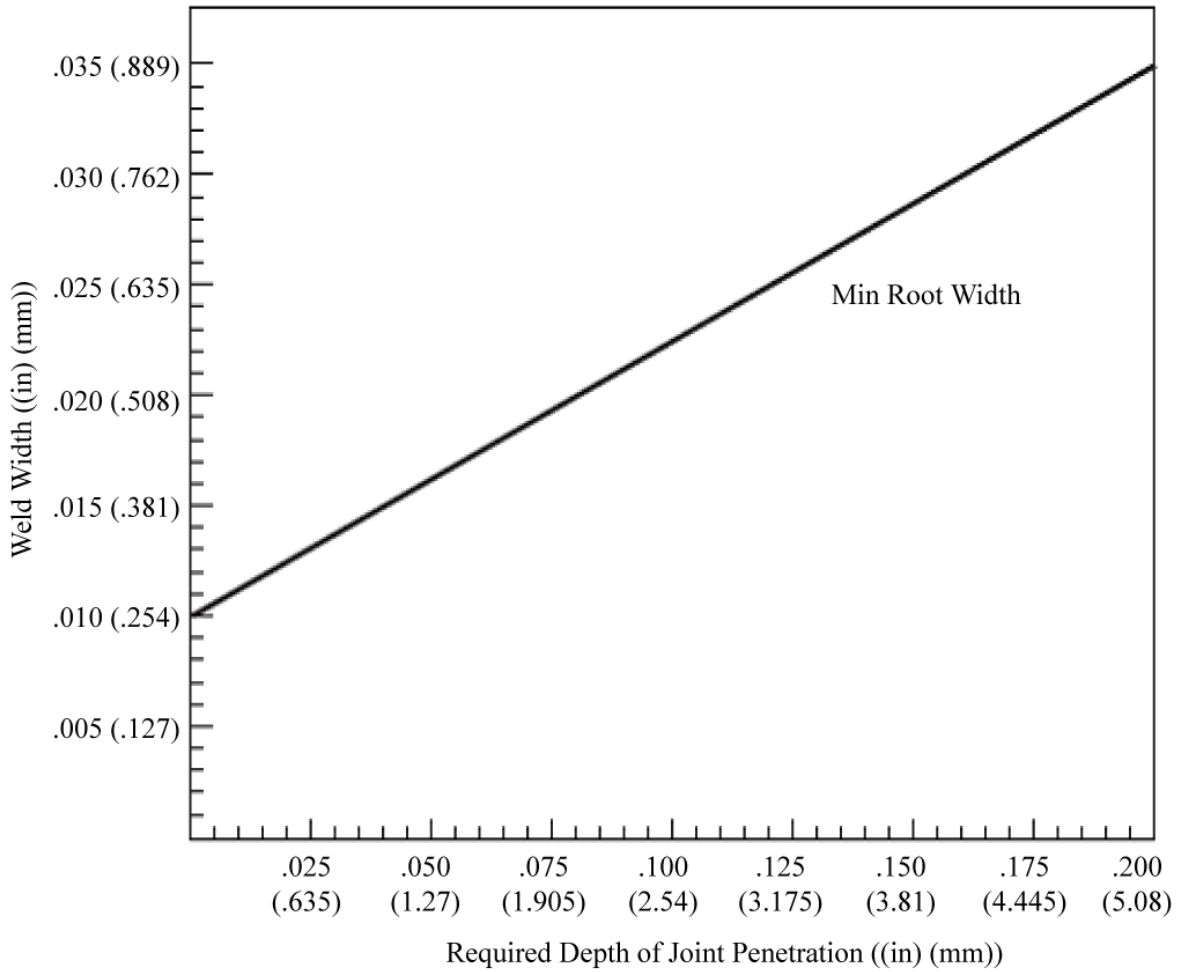

For accurate calculations, use the following formula: $ROOT_{min} = 0.010 + 0.125D$

Figure 8. Min EBW Root Width for Penetration Depths (D) ≤ 0.2 in [5 mm]

MSFC Technical Standard EM30		
Title: Process Specification – Welding Aerospace Hardware	Document No.: MSFC-SPEC-3679	Revision: A
	Effective Date: October 22, 2018	Page 50 of 92

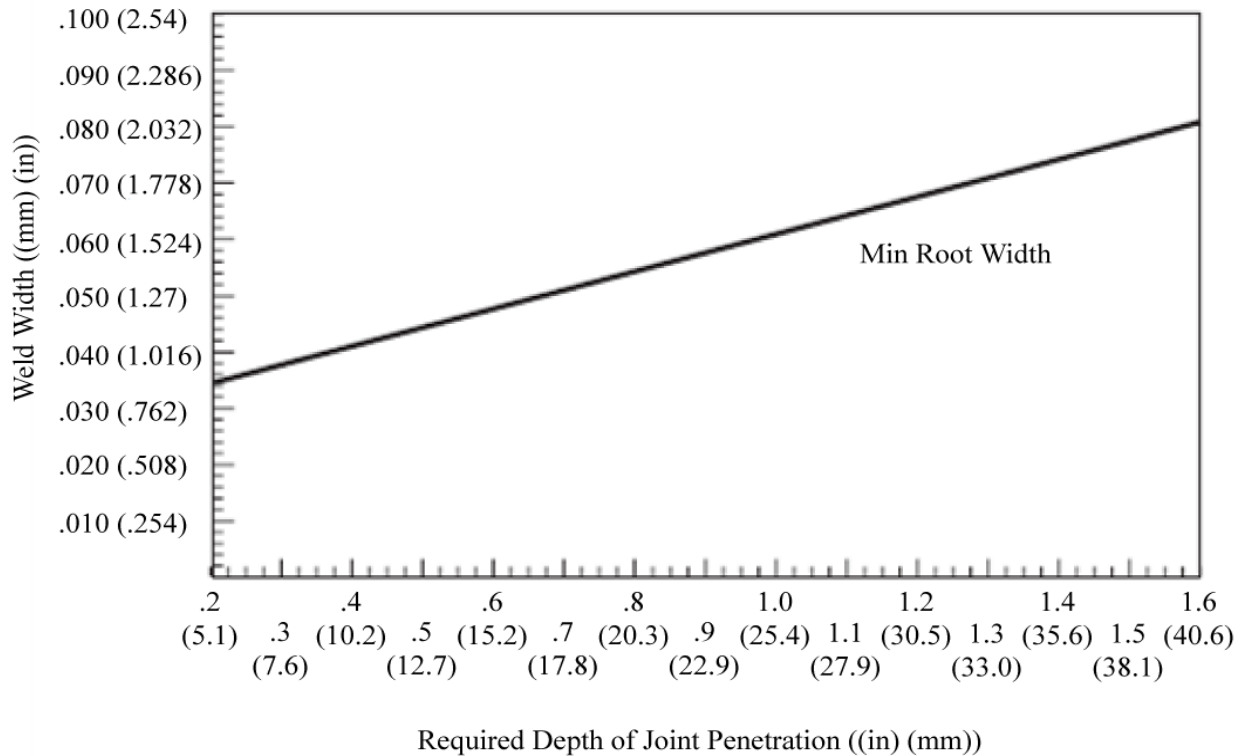

Note: For D > 1.6 in (>41 mm), the min root width shall be 0.080 in (2 mm).

For accurate calculations, use the following formula: $ROOT_{min} = 0.029 + 0.032D$

Figure 9. Min EBW Root Width for Penetration Depths (D) of 0.2-1.6 in [5-41 mm]

C.4 FRICION STIR WELDING

C4.1. Geometrical requirements for FSW shall be defined in the applicable Engineering documentation, as approved by the NASA Technical Authority.

C4.2. Reference joint thickness shall be listed on applicable Engineering documentation (i.e. Nominal, Minimum or As-Built thickness)

Table XIII, Figure 10 and Figure 11 may be used for reference as recommended FSW nugget dimensional characteristics.

Table XIII. Dimensional Characteristics of Aluminum Alloy Butt Welds

Process	Thickness in [mm]	Underthickness ¹
C-FSW	$0.188 \leq t \leq 1.250$ in [4.78 ≤ t ≤ 31.75]	5% below reference joint parent metal thickness.
SR-FSW	$0.188 \leq t \leq 0.750$ in [4.78 ≤ t ≤ 19.05]	10% below reference joint parent metal thickness.

¹Underthickness maximum is cumulative from crown and root for a given side (i.e. Advancing or Retreating).

CHECK THE MASTER LIST – VERIFY THAT THIS IS CORRECT VERSION BEFORE
USE

MSFC Technical Standard EM30		
Title: Process Specification – Welding Aerospace Hardware	Document No.: MSFC-SPEC-3679	Revision: A
	Effective Date: October 22, 2018	Page 51 of 92

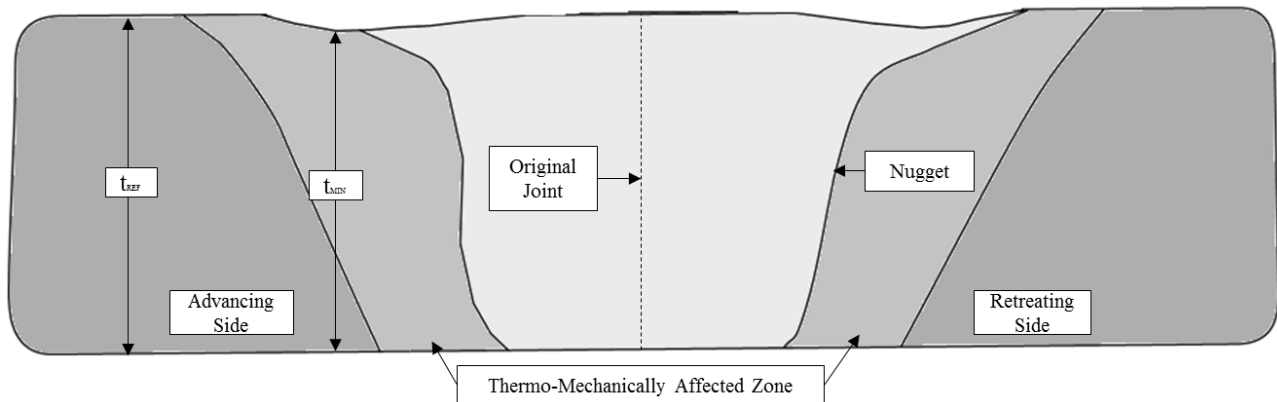

Figure 10. C-FSW Zone

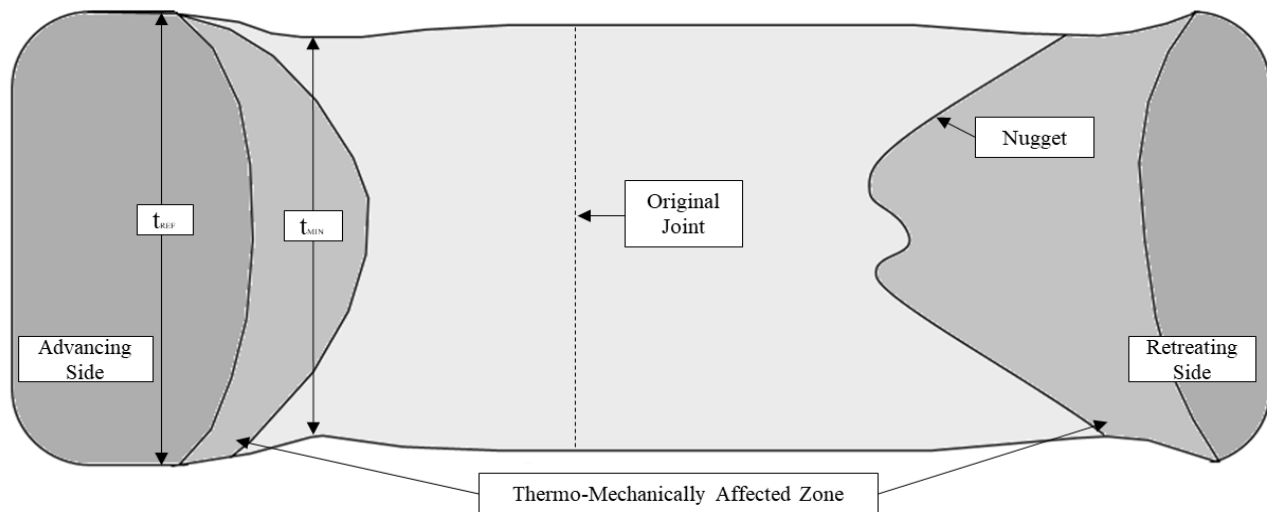

Figure 11. SR-FSW Zone

Notes:

$$\text{Underthickness} = t_{\text{REF}} - t_{\text{MIN}}$$

t_{MIN} may occur anywhere in weld joint

- a. for as-welded configurations t_{MIN} will likely occur at the toe of the weld in the heel plunge region
- b. for blended or re-worked configurations the thickness may be checked in re-worked area

t_{REF} defined in applicable engineering document and may vary with the program. Examples include, but are not limited to the following definitions:

- a. may be defined as nominal drawing base metal weld land thickness
- b. may be defined as minimum drawing base metal weld land thickness
- c. may be defined as as-built base metal weld land thickness

CHECK THE MASTER LIST – VERIFY THAT THIS IS CORRECT VERSION BEFORE
USE

MSFC Technical Standard EM30		
Title: Process Specification – Welding Aerospace Hardware	Document No.: MSFC-SPEC-3679	Revision: A
	Effective Date: October 22, 2018	Page 52 of 92

C.5 TITANIUM

Table XIV and Figure 12 thru Figure 16 provides titanium weld nugget dimensional requirements.

Table XIV. Dimensional Requirements

Thickness Nominal in [mm]		Class A Weld	Class B Weld
0 - 0.01 [0 - 0.254]	S(MAX)	0	.05t
	X(MIN)	0	0
	R(MAX)	$0.5t + 0.02$	$0.5t + 0.02$
	W(MAX)	0.09	0.09
0.01 - 0.02 [0.254 - 0.51]	S	0	0.05t
	X	0	0
	R	$0.5t + .02$	$0.5t + 0.02$
	W	0.18	0.18
0.02 - 0.03 [0.51 - 0.76]	S	0	.05t
	X	0	0
	R	$0.3t + 0.02$	$0.3t + 0.02$
	W	0.18	0.18
0.03 - 0.05 [0.76 - 1.27]	S	0	0.05t
	X	0	0
	R	$0.3t + 0.02$	$0.3t + 0.02$
	W	5.0t	5.0t
0.05 - 0.10 [1.27 - 2.54]	S	0	0.05t
	X	0	0
	R	$0.4t + 0.02$	$0.4t + 0.02$
	W	4.0t	4.0t
0.10 [2.54] and over	S	0	$0.05t$ or 0.03^1
	X	$0.05t$ or 0.03^1	0
	R	$0.6t$ or 0.09^1	$0.6t$ or 0.12
	W	In accordance with Figure 12	In accordance with Figure 12

¹Whichever is less

Figure 12 contains definitions.

MSFC Technical Standard EM30		
Title: Process Specification – Welding Aerospace Hardware	Document No.: MSFC-SPEC-3679	Revision: A
	Effective Date: October 22, 2018	Page 53 of 92

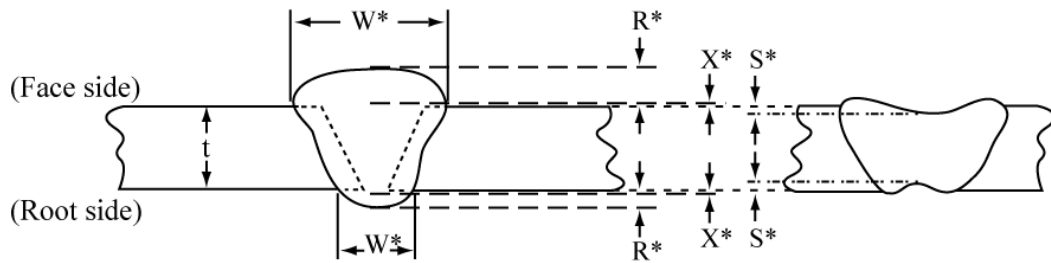

A. Full-Penetration Joint Welded from One Side

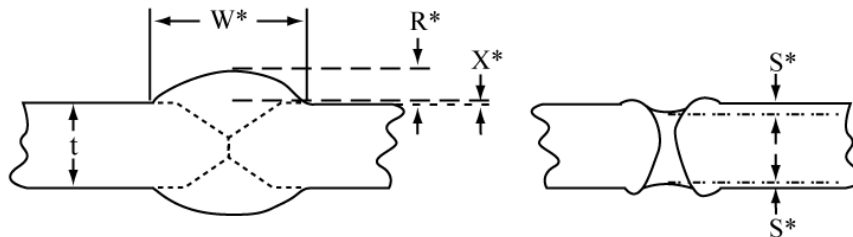

B. Full-Penetration Joint Welded from Both Sides
(R,S,W, and X limitations are the same for both sides of the weld.)

$R^* = R(\text{max})$; maximum reinforcement of weld, based on joint thickness

$S^* = S(\text{max})$; maximum weld bead concavity

$W^* = W(\text{max})$; maximum width of weld, based on joint thickness

$X^* = X(\text{min})$; minimum reinforcement of weld, based on joint thickness

The weld material contained within the minimum and maximum reinforcement limits (R-X) may be removed without rewelding.

Figure 12. Titanium Full-Penetration Joint Welds

MSFC Technical Standard EM30		
Title: Process Specification – Welding Aerospace Hardware	Document No.: MSFC-SPEC-3679	Revision: A
	Effective Date: October 22, 2018	Page 54 of 92

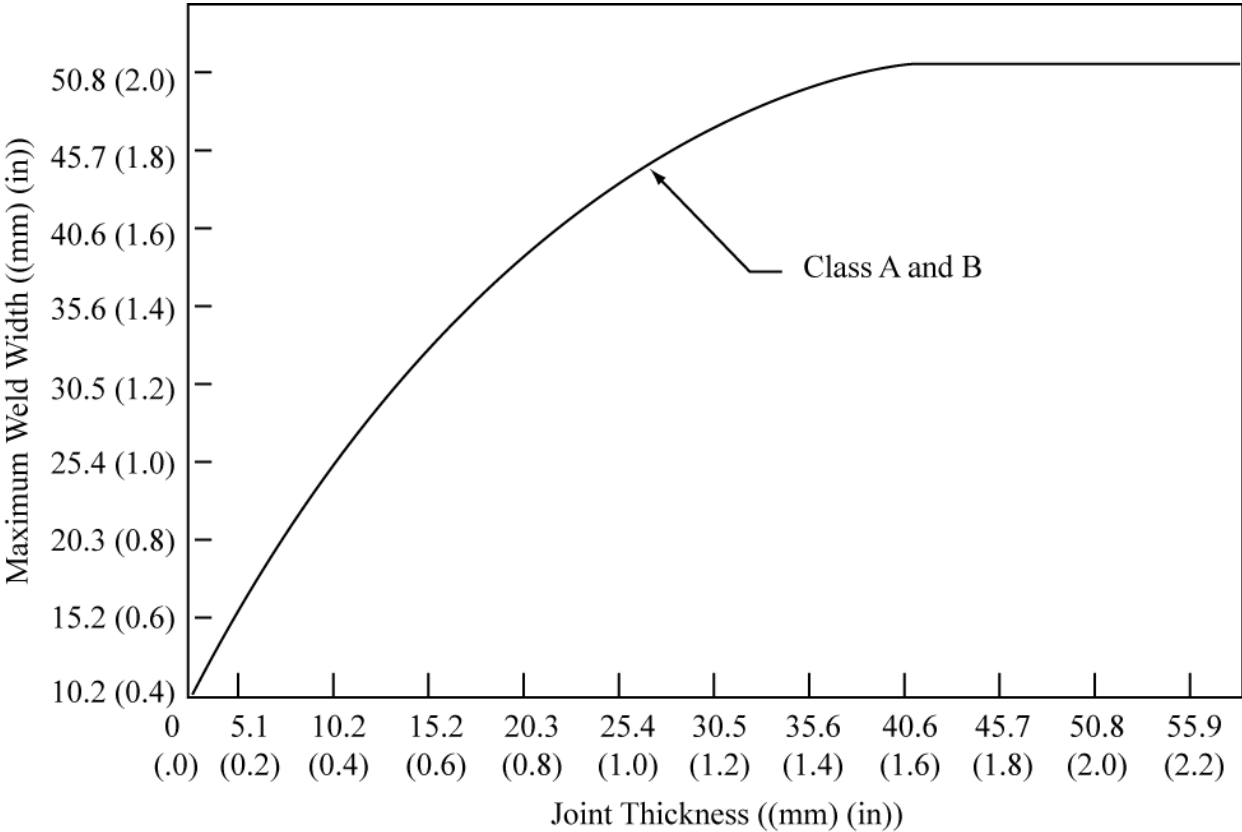
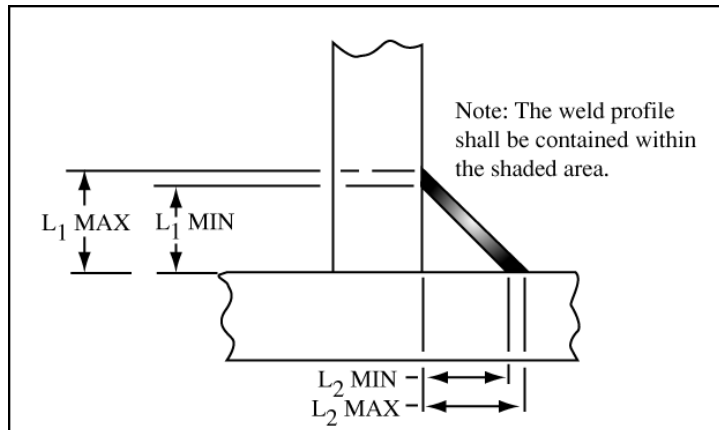

Figure 13. Titanium Butt Joint Maximum Allowable Weld Width (W) versus Thickness (t)

CHECK THE MASTER LIST – VERIFY THAT THIS IS CORRECT VERSION BEFORE
USE

MSFC Technical Standard EM30		
Title: Process Specification – Welding Aerospace Hardware	Document No.: MSFC-SPEC-3679	Revision: A
	Effective Date: October 22, 2018	Page 55 of 92



A. Right angle fillet weld

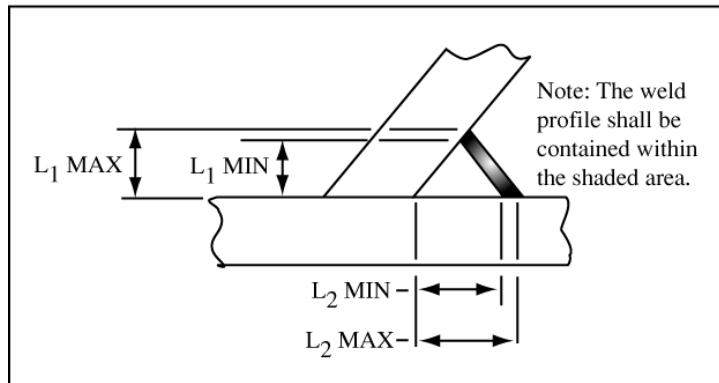

B. Acute angle fillet weld

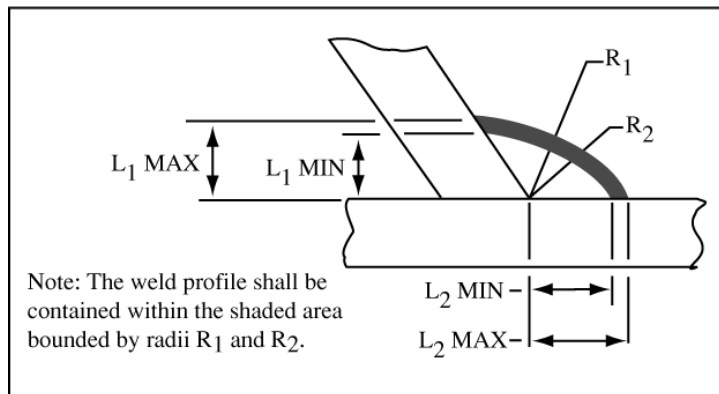

C. Obtuse angle fillet weld

Figure 14. Titanium Fillet Joint Maximum Allowable Weld Width versus Thickness

CHECK THE MASTER LIST – VERIFY THAT THIS IS CORRECT VERSION BEFORE USE

MSFC Technical Standard EM30		
Title: Process Specification – Welding Aerospace Hardware	Document No.: MSFC-SPEC-3679	Revision: A
	Effective Date: October 22, 2018	Page 56 of 92

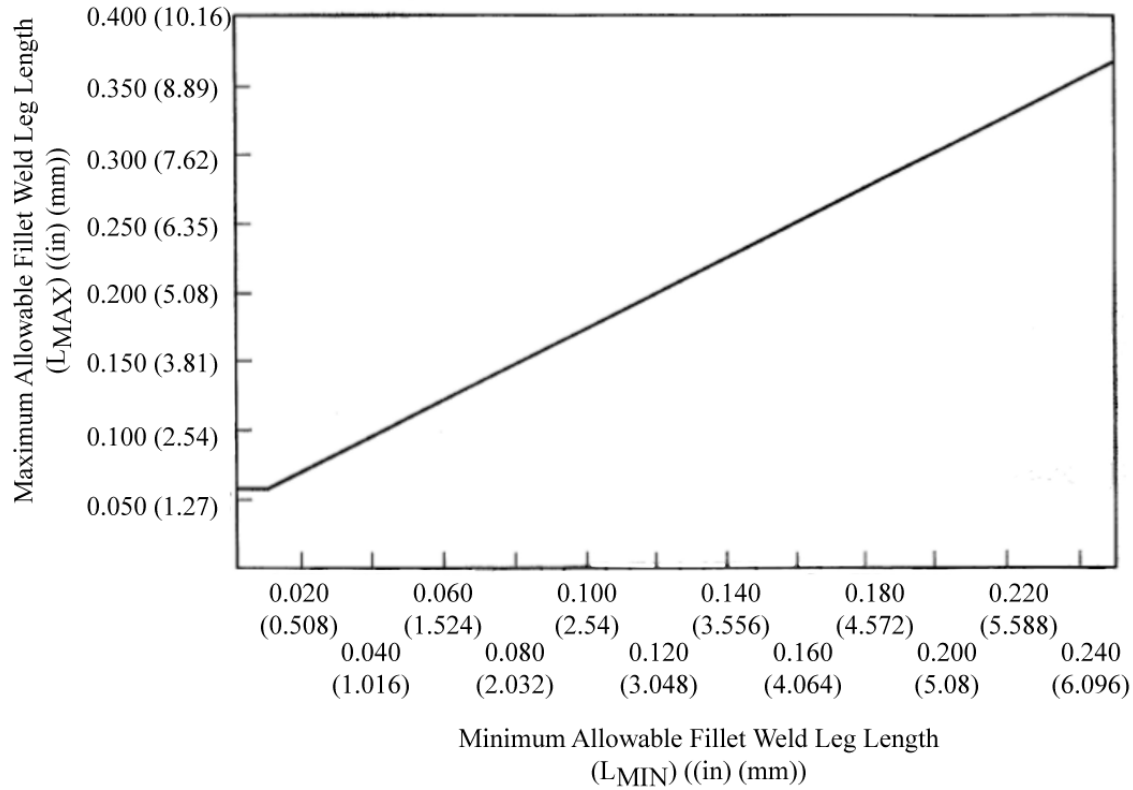

Note: The maximum leg length in welds of 0.251 in (6.375 mm) or greater designated size (L) shall be L+0.12 in (+3.048 mm).

Figure 15. Titanium Maximum Fillet Weld Size L_{MIN} = thickness of the thinnest member

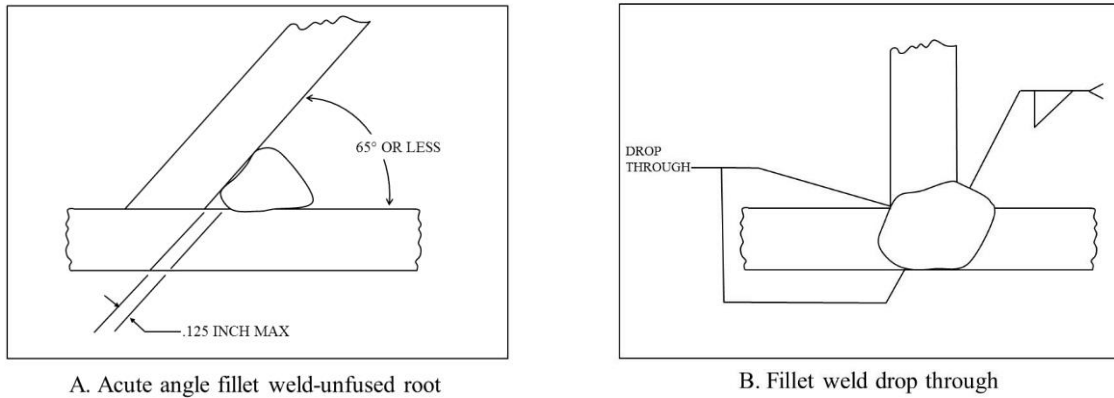

Figure 16. Titanium Fillet Weld Dimensions for Acute Angle and Drop Through

CHECK THE MASTER LIST – VERIFY THAT THIS IS CORRECT VERSION BEFORE USE

MSFC Technical Standard EM30		
Title: Process Specification – Welding Aerospace Hardware	Document No.: MSFC-SPEC-3679	Revision: A
	Effective Date: October 22, 2018	Page 57 of 92

C.6 SUPERALLOYS

Figure 17 thru Figure 24 provides superalloy weld nugget dimensional requirements.

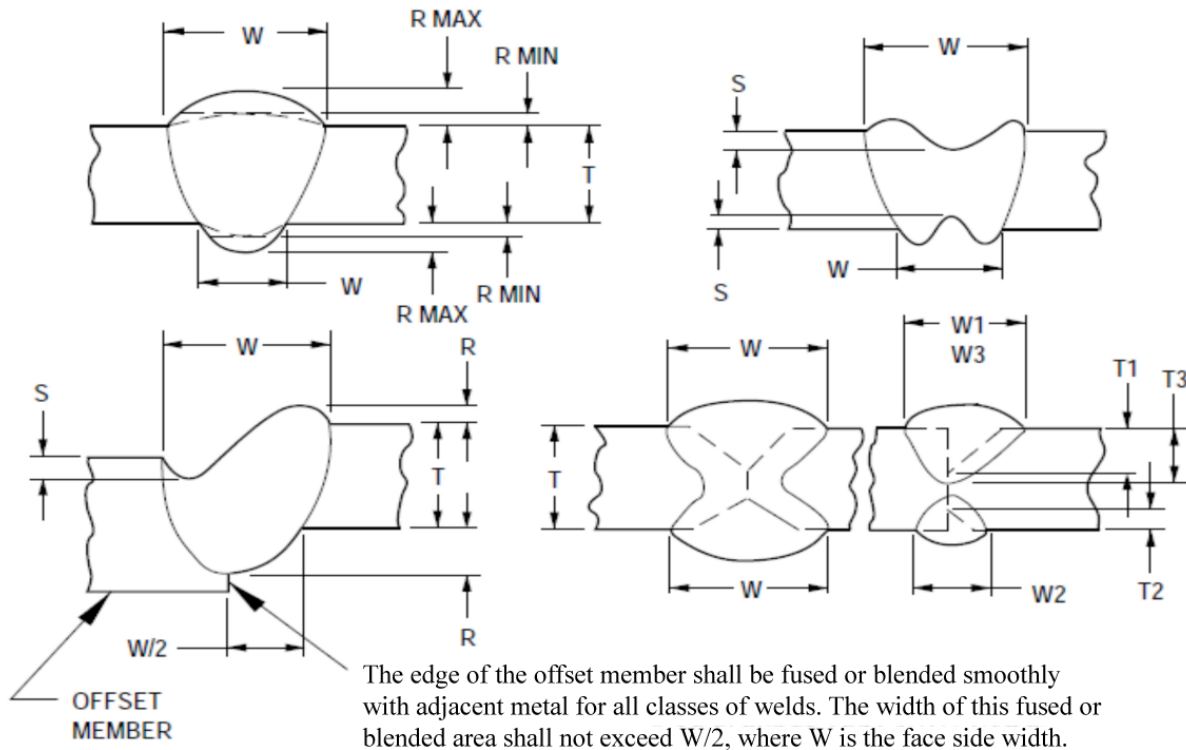

W = Maximum weld width. This dimension shall apply to the entire fusion zone, regardless of the number of weld passes.

T = Designated nominal material thickness of thicker member of full-penetration welds or specified groove depth (ref: $T1$, $T2$) of partial-penetration welds or specified penetration depth (ref: $T3$) of partial-penetration welds.

S = Maximum depth of weld concavity or suckback*.

R = Reinforcement. When flush contouring is required, R_{MAX} shall not exceed 0.015 in (0.381 mm) after reinforcement removal.

*Note: Concavity or suckback that is contained entirely within the face or root reinforcement is acceptable.

Figure 17. Weld Size Requirements for Butt Welds

**MSFC Technical Standard
EM30**

**Title: Process Specification – Welding
Aerospace Hardware**

**Document No.: MSFC-SPEC-3679
Effective Date: October 22, 2018**

**Revision: A
Page 58 of 92**

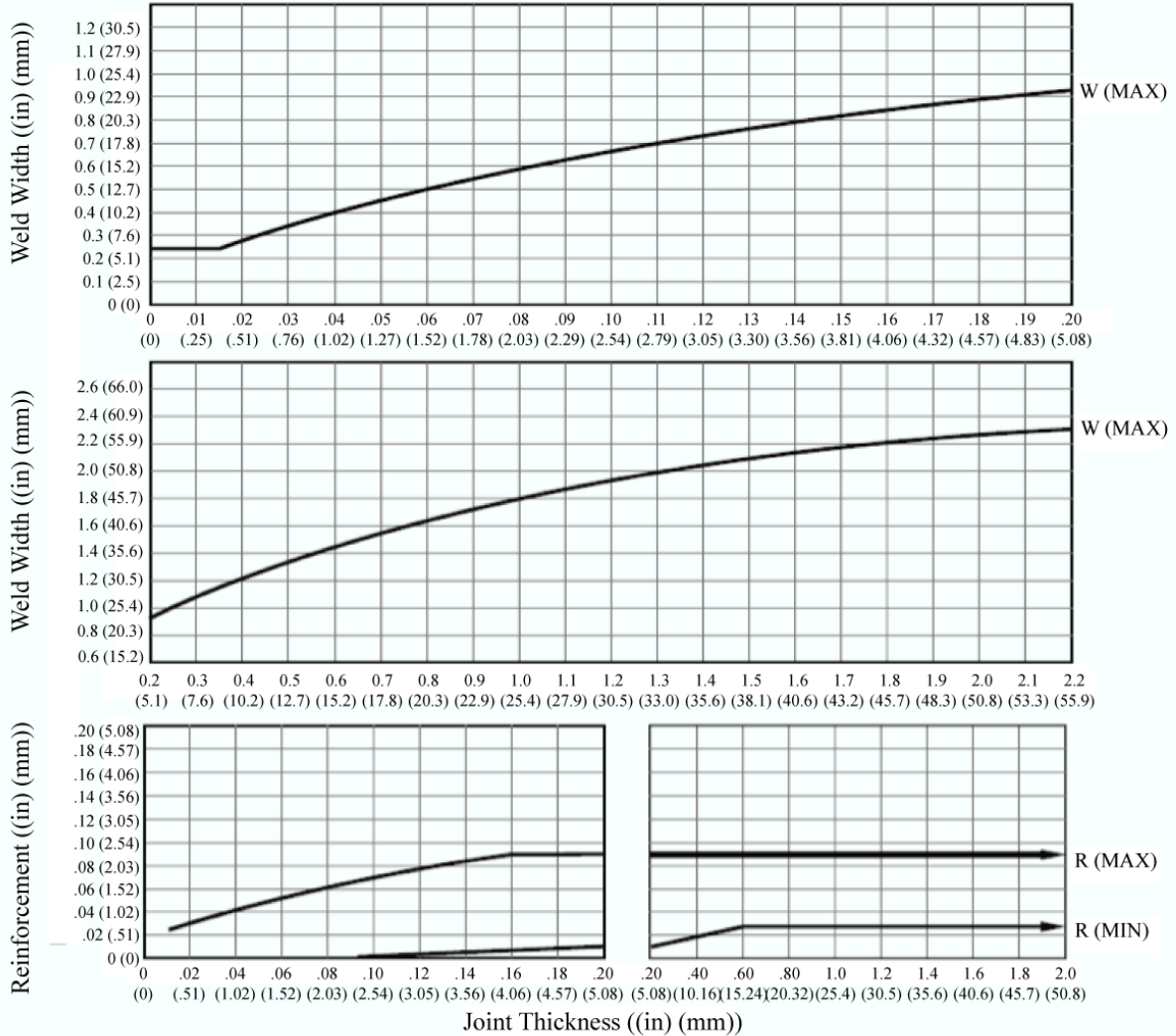

S=0 for all joint thicknesses

Figure 18. Class A Butt Weld Fusion Zone Weld Size Limits

CHECK THE MASTER LIST – VERIFY THAT THIS IS CORRECT VERSION BEFORE
USE

MSFC Technical Standard EM30		
Title: Process Specification – Welding Aerospace Hardware	Document No.: MSFC-SPEC-3679	Revision: A
	Effective Date: October 22, 2018	Page 59 of 92

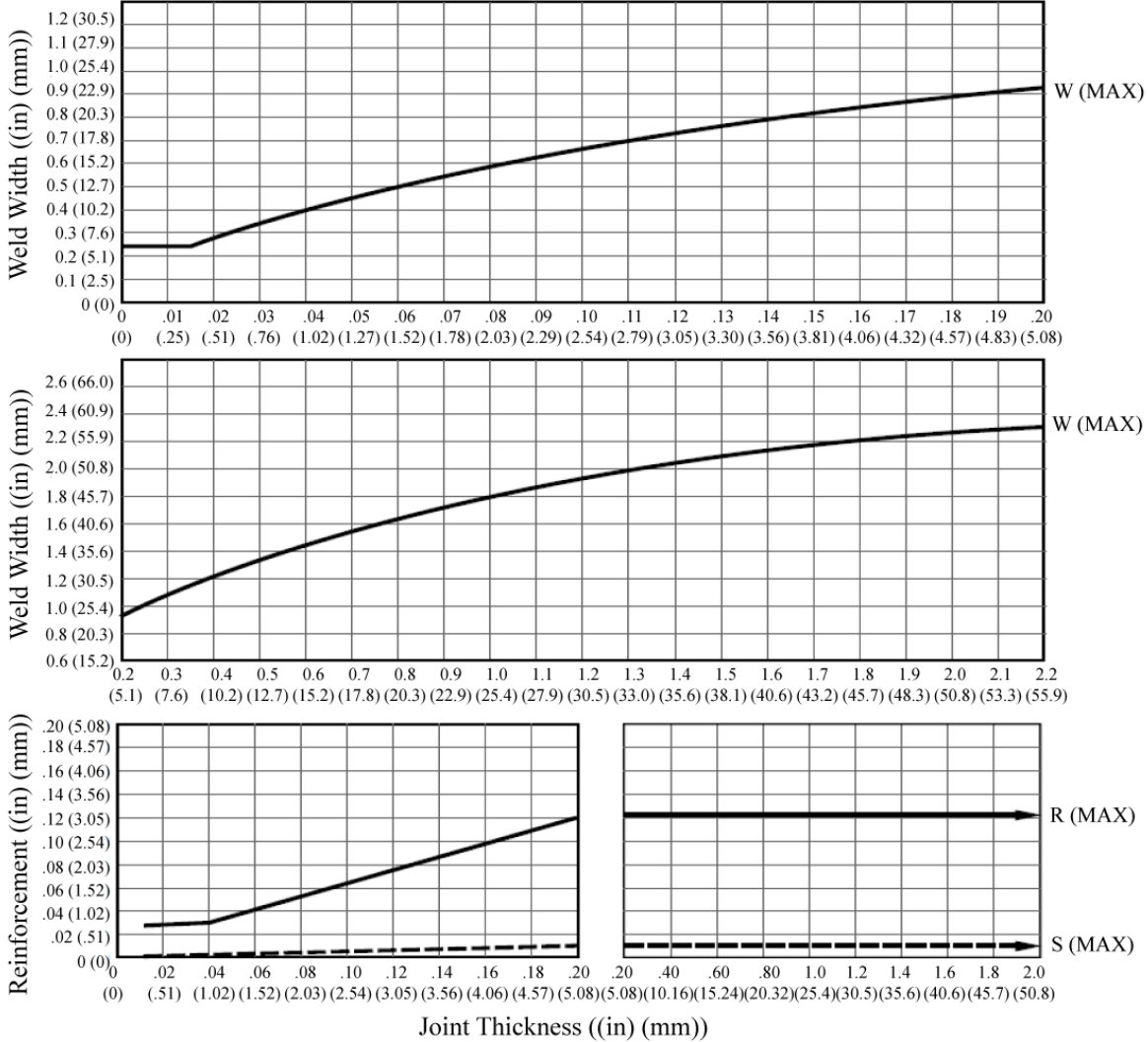

R (MIN)=0 for all joint thicknesses

Figure 19. Class B Butt Weld Fusion Zone Weld Size Limits

CHECK THE MASTER LIST – VERIFY THAT THIS IS CORRECT VERSION BEFORE USE

**MSFC Technical Standard
EM30**

**Title: Process Specification – Welding
Aerospace Hardware**

**Document No.: MSFC-SPEC-3679
Effective Date: October 22, 2018**

**Revision: A
Page 60 of 92**

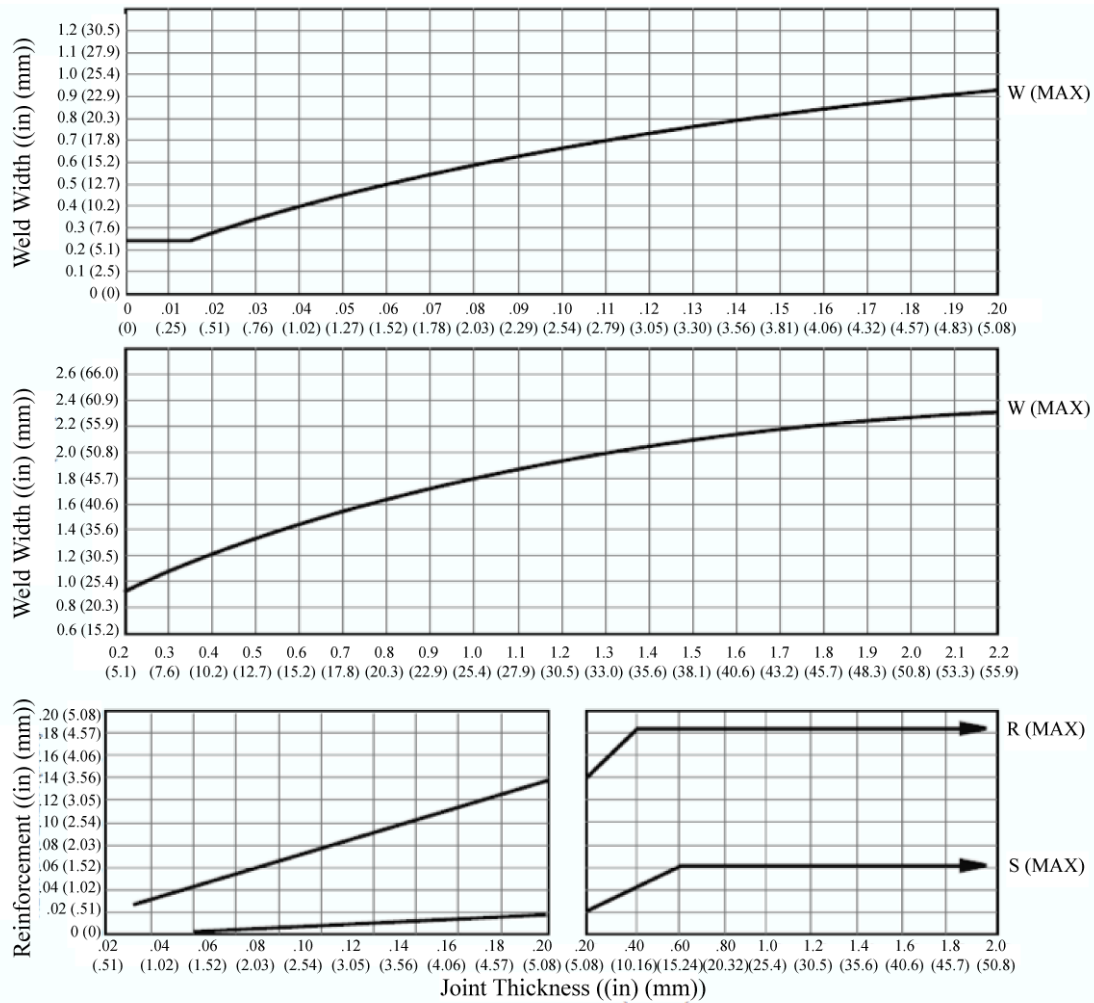

R (MIN)=0 for all joint thicknesses

Figure 20. Class C Butt Weld Fusion Zone Weld Size Limits

CHECK THE MASTER LIST – VERIFY THAT THIS IS CORRECT VERSION BEFORE
USE

MSFC Technical Standard EM30		
Title: Process Specification – Welding Aerospace Hardware	Document No.: MSFC-SPEC-3679	Revision: A
	Effective Date: October 22, 2018	Page 61 of 92

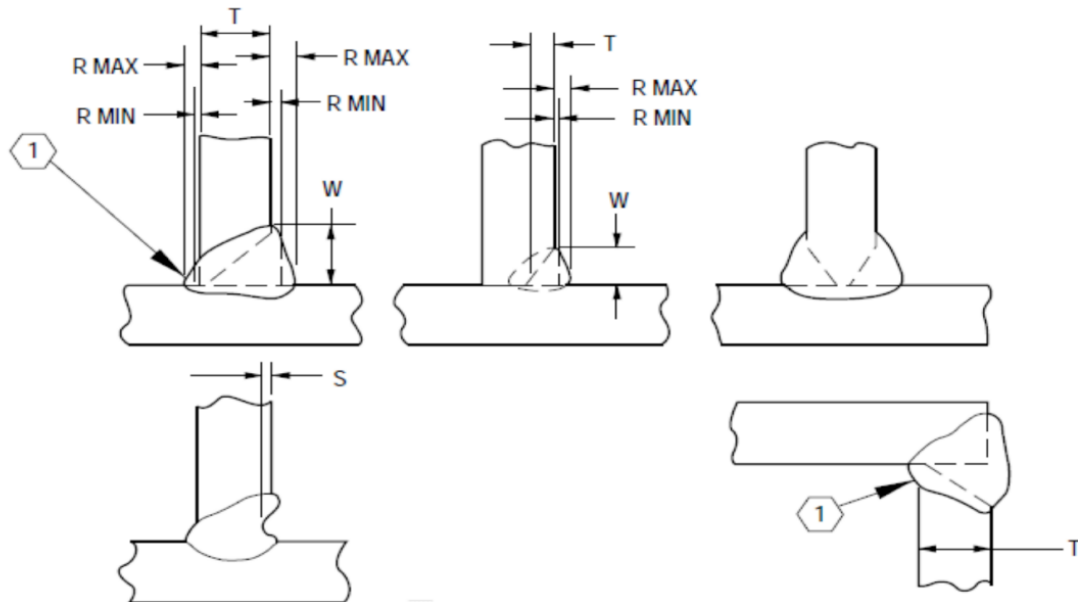

① Fillet weld may be added on root side within reinforcement dimensions.
S, X, R, and W requirements are the same for both sides.

W = Maximum weld width. This dimension shall apply to the entire fusion zone, regardless of the number of weld passes.

T = Designated nominal material thickness of the grooved member of full-penetration welds or specified groove depth of partial-penetration welds or specified penetration depth of partial-penetration welds.

S = Maximum depth of weld concavity or suckback*.

R = Reinforcement. Mechanical removal of excess face buildup or (root) droptrough is permissible. Full-penetration welds may have a fillet weld added on the root side within the maximum reinforcement dimensions.

*Note: Concavity or suckback that is contained entirely within the face or root reinforcement is acceptable.

Figure 21. Weld Size Requirements for T and Corner Welds

**MSFC Technical Standard
EM30**

Title: Process Specification – Welding Aerospace Hardware	Document No.: MSFC-SPEC-3679	Revision: A
	Effective Date: October 22, 2018	Page 62 of 92

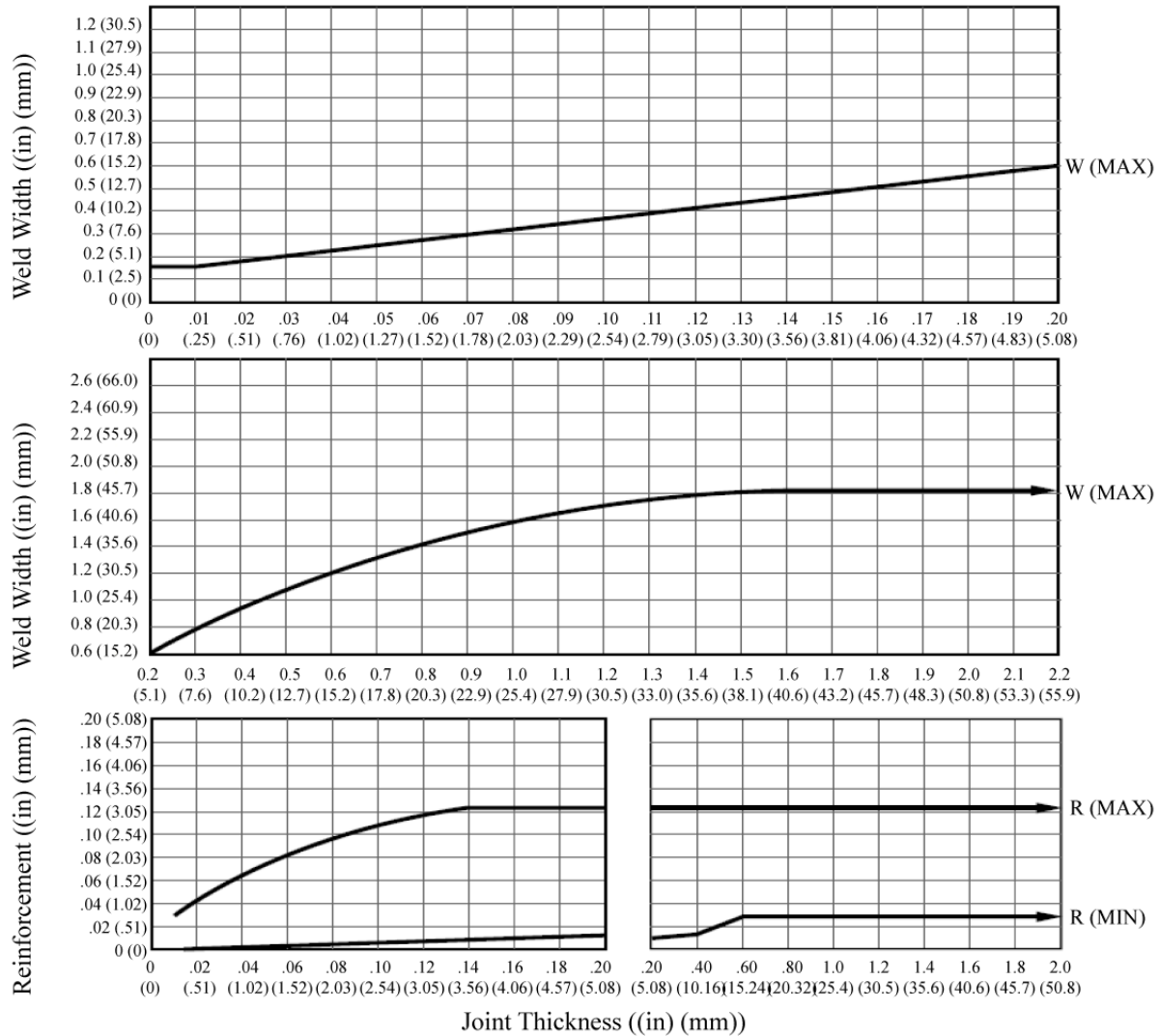

S=0 for all joint thicknesses

Figure 22. Class A, T and Corner Weld Fusion Zone Weld Size Limits

CHECK THE MASTER LIST – VERIFY THAT THIS IS CORRECT VERSION BEFORE
USE

MSFC Technical Standard EM30		
Title: Process Specification – Welding Aerospace Hardware	Document No.: MSFC-SPEC-3679	Revision: A
	Effective Date: October 22, 2018	Page 63 of 92

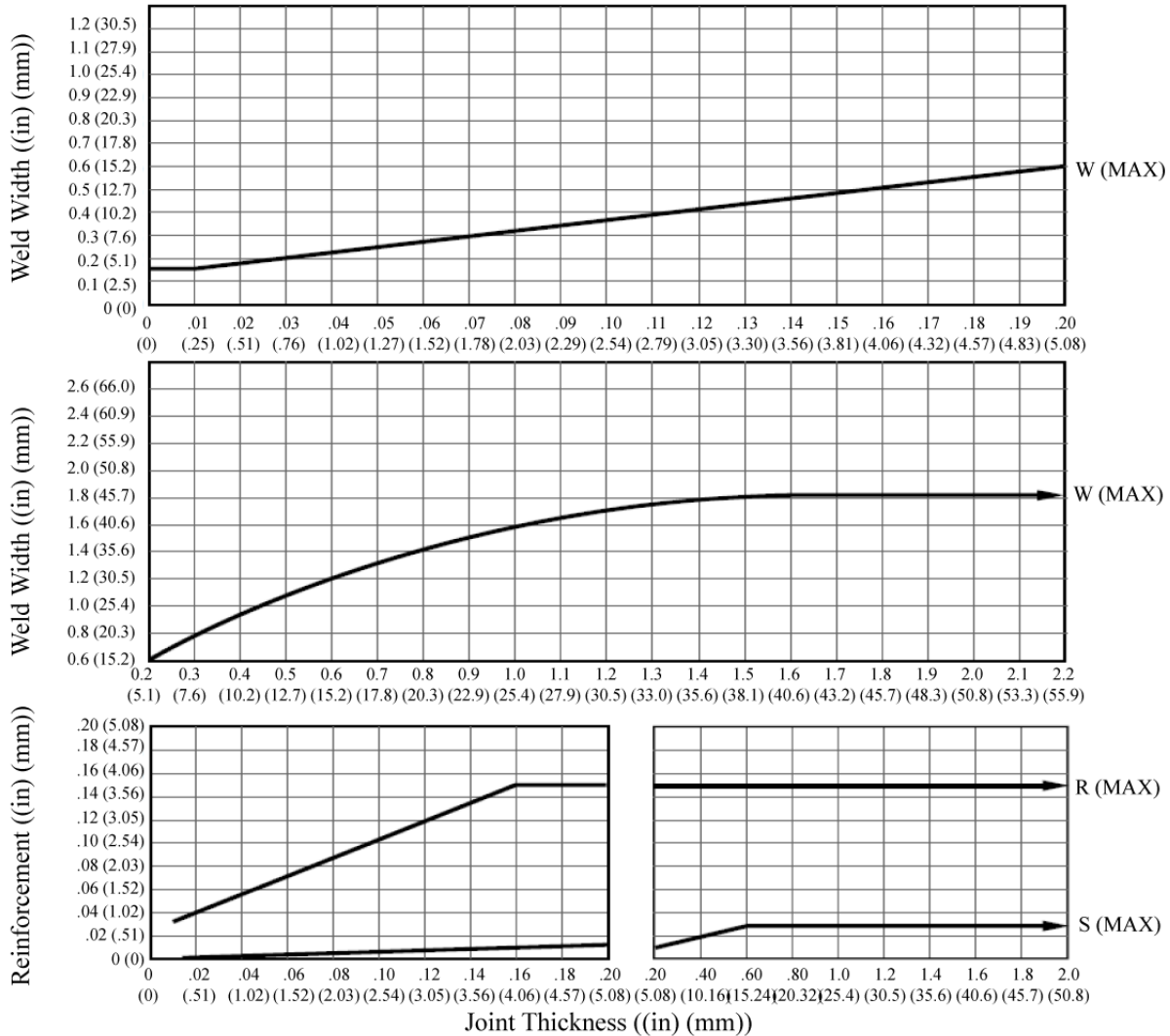

S=0 for all joint thicknesses

Figure 23. Class B, T and Corner Weld Fusion Zone Weld Size Limits

CHECK THE MASTER LIST – VERIFY THAT THIS IS CORRECT VERSION BEFORE USE

MSFC Technical Standard EM30		
Title: Process Specification – Welding Aerospace Hardware	Document No.: MSFC-SPEC-3679	Revision: A
	Effective Date: October 22, 2018	Page 64 of 92

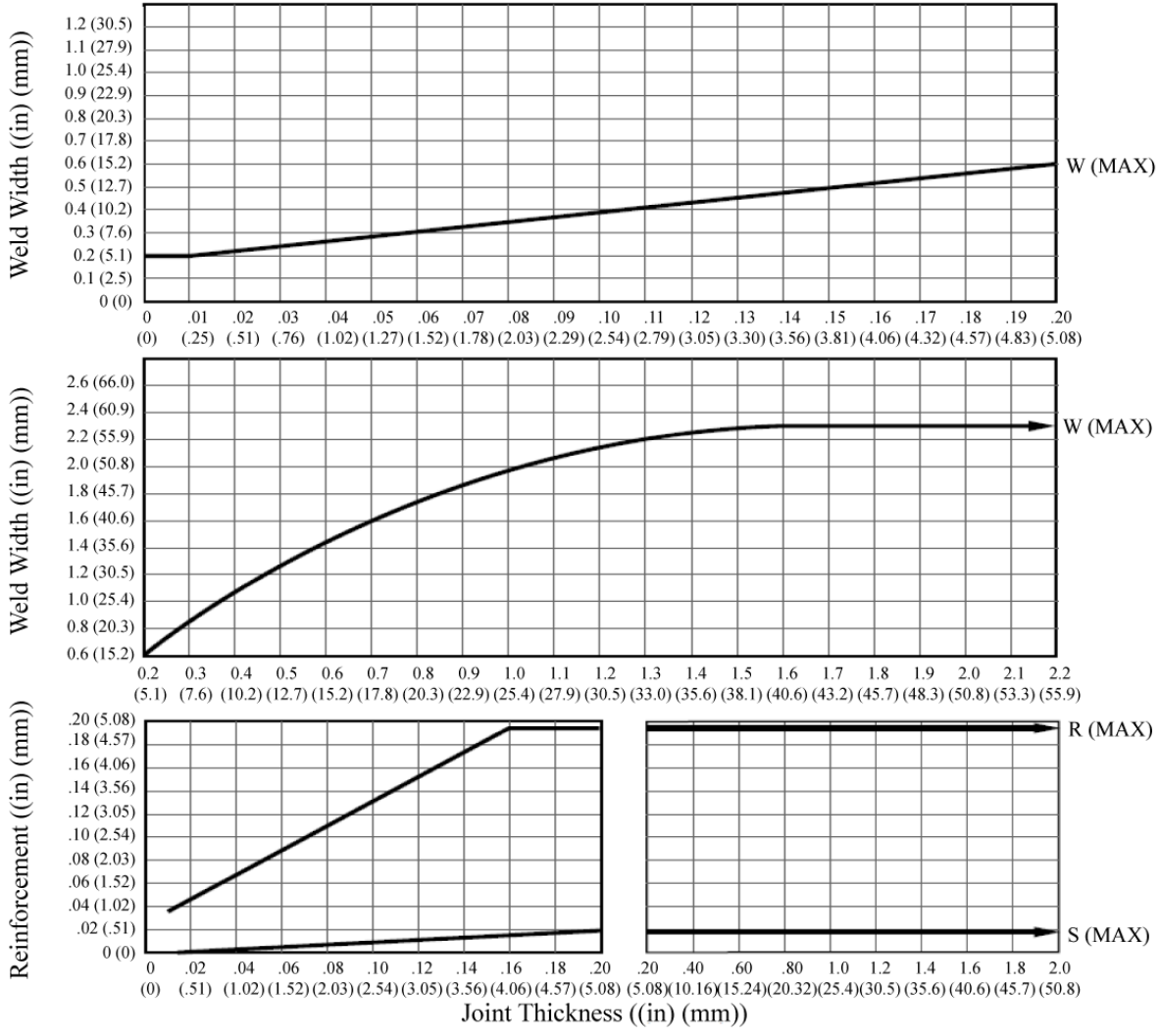

R (MIN)=0 for all joint thicknesses

Figure 24. Class C, T and Corner Weld Fusion Zone Weld Size Limits

CHECK THE MASTER LIST – VERIFY THAT THIS IS CORRECT VERSION BEFORE USE

MSFC Technical Standard EM30		
Title: Process Specification – Welding Aerospace Hardware	Document No.: MSFC-SPEC-3679	Revision: A
	Effective Date: October 22, 2018	Page 65 of 92

Appendix D Weld Quality Requirements

D.1 PURPOSE AND/OR SCOPE

The purpose of this appendix is to provide weld accept/reject criteria requirements.

D.2 ACCEPTANCE CRITERIA

Table XV thru Table XVII and Figure 25 thru Figure 27 present weld surface acceptance criteria for various metal alloys.

Table XV. Weld Surface and Volumetric Acceptance Criteria – Aluminum Alloys

Process	Discontinuity	Class A, in [mm]	Class B, in [mm]	Class C, in [mm]	
All	Cracks	None allowed	None allowed	None allowed	
	Overlap (cold lap)	None allowed	None allowed	None allowed	
	Incomplete Fusion	None allowed	None allowed	None allowed	
	Incomplete Penetration	None allowed	None allowed	None allowed for full-penetration welds	
	Undercut, concavity, lack of fill, suckback	None allowed where it occurs as a sharp notch or where the depth reduces the material thickness below drawing requirements	None allowed where it occurs as a sharp notch or where the depth reduces the material thickness below drawing requirements	None allowed where it occurs as a sharp notch or where the depth reduces the material thickness below drawing requirements	
Fusion	Surface porosity, oxides	Butt Joints	t/3 or 0.065 [1.65], whichever is smaller	t/2 or 0.100 [2.54], whichever is smaller	N/A
		Fillet Weld	S/3 or 0.050 [1.27], whichever is smaller	S/3 or 0.075 [1.9], whichever is smaller	N/A
		Scattered	Sum of the areas of all individual surface discontinuities within any 1.0 [25.4] of weld shall be less than 1/2 the maximum discontinuity area in Figure 25.	Sum of the areas of all individual surface discontinuities within any 1.0 [25.4] of weld shall be less than 1/2 the maximum discontinuity area in Figure 25.	N/A
		Scattered	No more than 15 individual surface discontinuities in any 1.0 [25.4] regardless of size are allowed.	N/A	N/A

CHECK THE MASTER LIST – VERIFY THAT THIS IS CORRECT VERSION BEFORE USE

MSFC Technical Standard EM30		
Title: Process Specification – Welding Aerospace Hardware	Document No.: MSFC-SPEC-3679	Revision: A
	Effective Date: October 22, 2018	Page 66 of 92

Process	Discontinuity	Class A, in [mm]	Class B, in [mm]	Class C, in [mm]	
Fusion	Surface porosity, oxides	Linear	Three or more in a line are rejectable if the line extends more than 0.25 [6.35] and the discontinuities occupy more than 50% of the length of line.	Three or more in a line are rejectable if the line extends more than 0.50 [12.7] and the discontinuities occupy more than 50% of the length of line.	N/A
		Sharp	Rejectable if maximum dimension exceeds 0.100 [2.54].	Rejectable if maximum dimension exceeds 0.100 [2.54].	N/A
		Cluster	Three or more discontinuities each measuring 0.01 [0.254] or more, touching or falling within a 0.25 [6.35] diameter circle, shall be classified as a cluster when the sum of their maximum dimension exceeds $t/3$ or 0.065 [1.65] for butt welds and $S/3$ or 0.05 [1.27] for fillet, whichever is smaller. Two clusters are rejectable if separated by less than butt weld thickness (t) or less than specified fillet size (S).	Three or more discontinuities each measuring 0.02 [0.508] or more, touching or falling within a 0.25 [6.35] diameter circle, shall be classified as a cluster when the sum of their dimensions exceeds $t/3$ or 0.065 [1.65] for butt welds, and $S/3$ or 0.050 [1.27] for fillet welds, whichever is smaller for each weld. Two clusters are rejectable if separated by less than half the butt weld thickness ($t/2$) or less than half the specified fillet size ($S/2$).	N/A
	Volumetric voids, inclusions	Close Spacing	Discontinuities that appear overlapping, touching, or connected viewed normal to the weld surface for butt welds and at an optimum angle for fillet welds shall be treated as a single discontinuity. The spacing requirement is not applicable to discontinuities connected to the root of the weld for fillet welds.	Discontinuities that appear overlapping, touching, or connected viewed normal to the weld surface for butt welds and at an optimum angle for fillet welds shall be treated as a single discontinuity. The spacing requirement is not applicable to discontinuities connected to the root of the weld for fillet welds.	N/A
		Maximum Size	The maximum dimension of an individual internal discontinuity as viewed normal to the weld surface for butt welds and at an optimum angle for fillet welds shall not exceed the values obtained from Figure 26.	The maximum dimension of an individual internal discontinuity as viewed normal to the weld surface for butt welds and at an optimum angle for fillet welds shall not exceed the value obtained in Figure 26.	N/A
		Scattered	Scattered internal discontinuities not exceeding individual discontinuity limitations shall be evaluated for accumulative area per 1 [25.4] of weld. Area calculations shall be based on best fit circle or rectangle. Butt and fillet welds, including discontinuities connected to the root of fillet welds, shall conform to the requirements of Figure 26.	Scattered internal discontinuities not exceeding the individual discontinuity limitations shall be evaluated for accumulative area per 1 [25.4] of weld. In addition, all discontinuities connected to the root of a fillet weld shall be included in the accumulative area. Area calculations shall be based on the best fit circle or rectangle. The area in any 1 [25.4] of weld shall not exceed the value obtained from Figure 26.	N/A

CHECK THE MASTER LIST – VERIFY THAT THIS IS CORRECT VERSION BEFORE USE

MSFC Technical Standard EM30		
Title: Process Specification – Welding Aerospace Hardware	Document No.: MSFC-SPEC-3679	Revision: A
	Effective Date: October 22, 2018	Page 67 of 92

Process	Discontinuity	Class A, in [mm]	Class B, in [mm]	Class C, in [mm]	
Fusion	Volumetric voids, inclusions	Scattered - butt welds	Any 1 [25.4] of weld with maximum allowable area of Figure 26 shall have no more than one-half the maximum allowable area in each adjacent 1 [25.4] of weld.	N/A	N/A
		Scattered - butt weld intersections	That 6 [152], i.e., 3 [76] to each side of the intersection, of weld intersection by another weld shall have the maximum allowable area of Figure 26 reduced by 1/3.	N/A	N/A
		Scattered	There shall be no more than 15 discontinuities in any 1 [25.4] of weld regardless of size or cumulative area loss.	N/A	N/A
		Linear	Three or more discontinuities, which are in line, are unacceptable if the line extends more than 0.25 [6.35] and the discontinuities occupy more than 50% of the length of the line. This requirement is not applicable to discontinuities connected to the root of fillet welds.	Three or more discontinuities, which are in a line, are unacceptable if the line extends more than 0.5 [12.7] and the discontinuities occupy more than 50% of the length of the line. This requirement is not applicable to discontinuities connected to the root of fillet welds.	N/A
		Sharp	Any discontinuity that appears to have a crack-like extension shall be cause for rejection. If the longest accumulative dimension is more than 5X the width at the smallest dimension, the indication shall be cause for rejection. This requirement is not applicable to discontinuities connected to the root of fillet welds.	Any discontinuity that appears to have a crack-like extension shall be cause for rejection. If the longest accumulative dimension is more than 7X the width at the smallest dimension, the discontinuity shall be cause for rejection. This requirement is not applicable to discontinuities connected to the root of fillet welds.	N/A
		Cluster	Three or more discontinuities, each measuring 0.010 [0.254] or more, touching or falling within a 0.25 [6.35] diameter circle, shall be classified as a cluster when the sum of their dimensions exceeds the allowable maximum dimension of an individual discontinuity in Figure 26. For butt welds, two clusters are unacceptable if separated by less than the material thickness. For fillet welds, two clusters are unacceptable if separated by less than the specified fillet weld size (S/2). This requirement is not applicable to discontinuities connected to the root of the fillet welds.	Three or more discontinuities, each measuring 0.02 [0.508] or more, touching or falling within a 0.25 [6.35] diameter circle, shall be classified as a cluster when the sum of their maximum dimensions exceeds the allowable maximum dimension of an individual discontinuity in Figure 26. For butt welds, two clusters are unacceptable if separated by less than half the material thickness (t/2). For fillet welds, two clusters are unacceptable if separated by less than half the specified fillet size (S/2). This requirement is not applicable to discontinuities connected to the root of fillet welds.	N/A

CHECK THE MASTER LIST – VERIFY THAT THIS IS CORRECT VERSION BEFORE USE

MSFC Technical Standard EM30		
Title: Process Specification – Welding Aerospace Hardware	Document No.: MSFC-SPEC-3679	Revision: A
	Effective Date: October 22, 2018	Page 68 of 92

Process	Discontinuity	Class A, in [mm]	Class B, in [mm]	Class C, in [mm]
Friction	Surface	Galling or tears on the surface of the weld visually indicated by open surface features or blisters shall be cause for rejection.	Galling or tears on the surface of the weld visually indicated by open surface features or blisters shall be cause for rejection.	N/A
	Volumetric voids, inclusions	Wormholes/voids/lack of adequate forgings shall be cause for rejection.	Wormholes/voids/lack of adequate forging shall be cause for rejection.	N/A
Electron Beam	Undercut and concavity	Sharp crevice at root		
		Thin weldment below minimum drawing requirements - rejectable		
		Exceed a depth of 0.05t or 0.040 [1], whichever is less - rejectable		
		Exceed a width of 0.25t or 0.08 [2], whichever is less - rejectable		
	Exceed a length of 0.5 [12.7] for any single indication or a total of 1.5 [38] in any 6 [152] length - rejectable			
	Volumetric porosity/inclusions	Accept per SAE AMS 2680		

CHECK THE MASTER LIST – VERIFY THAT THIS IS CORRECT VERSION BEFORE USE

MSFC Technical Standard EM30		
Title: Process Specification – Welding Aerospace Hardware	Document No.: MSFC-SPEC-3679	Revision: A
	Effective Date: October 22, 2018	Page 69 of 92

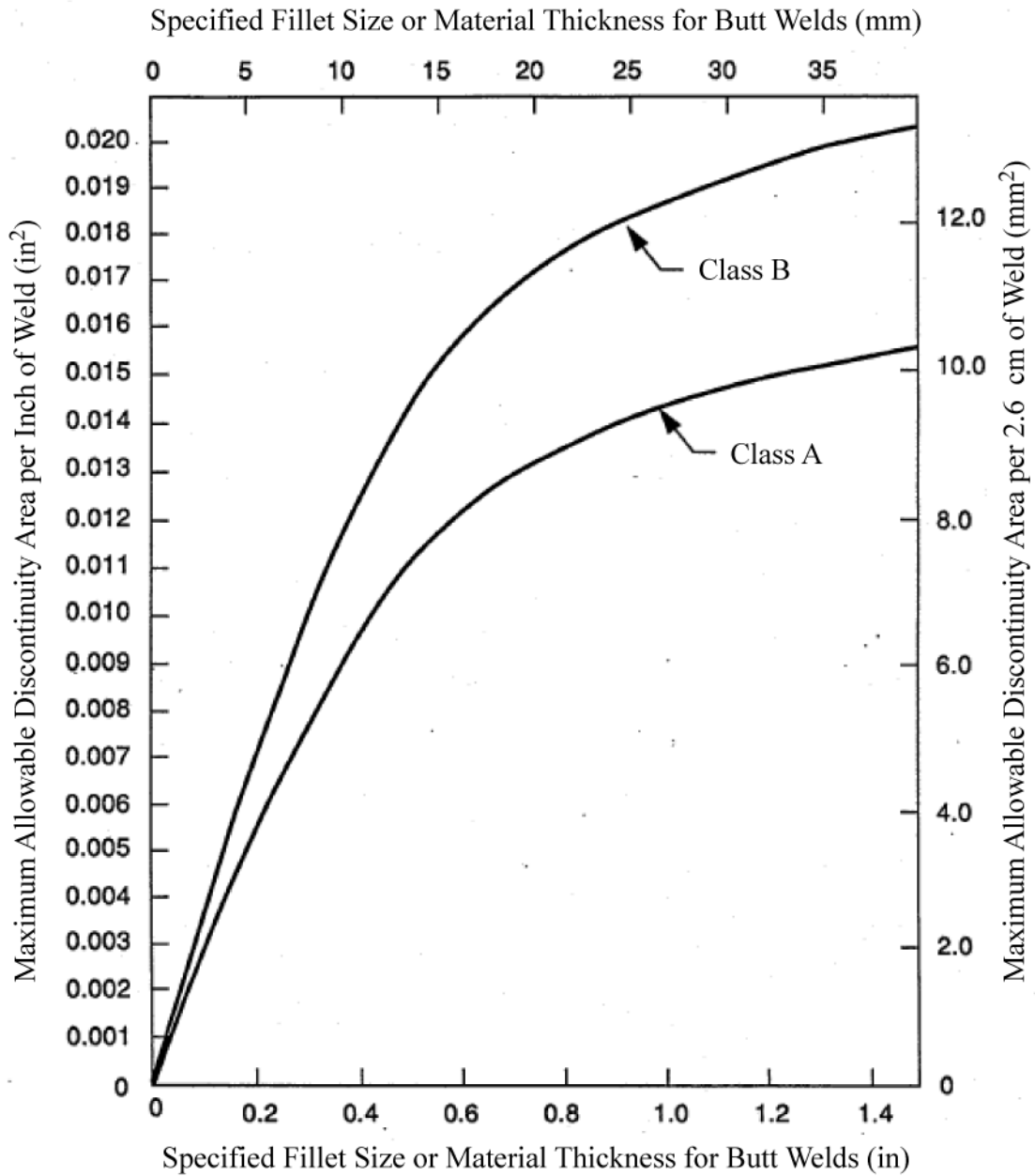

Figure 25. External Discontinuities for Aluminum Alloys

CHECK THE MASTER LIST – VERIFY THAT THIS IS CORRECT VERSION BEFORE
USE

MSFC Technical Standard EM30		
Title: Process Specification – Welding Aerospace Hardware	Document No.: MSFC-SPEC-3679	Revision: A
	Effective Date: October 22, 2018	Page 70 of 92

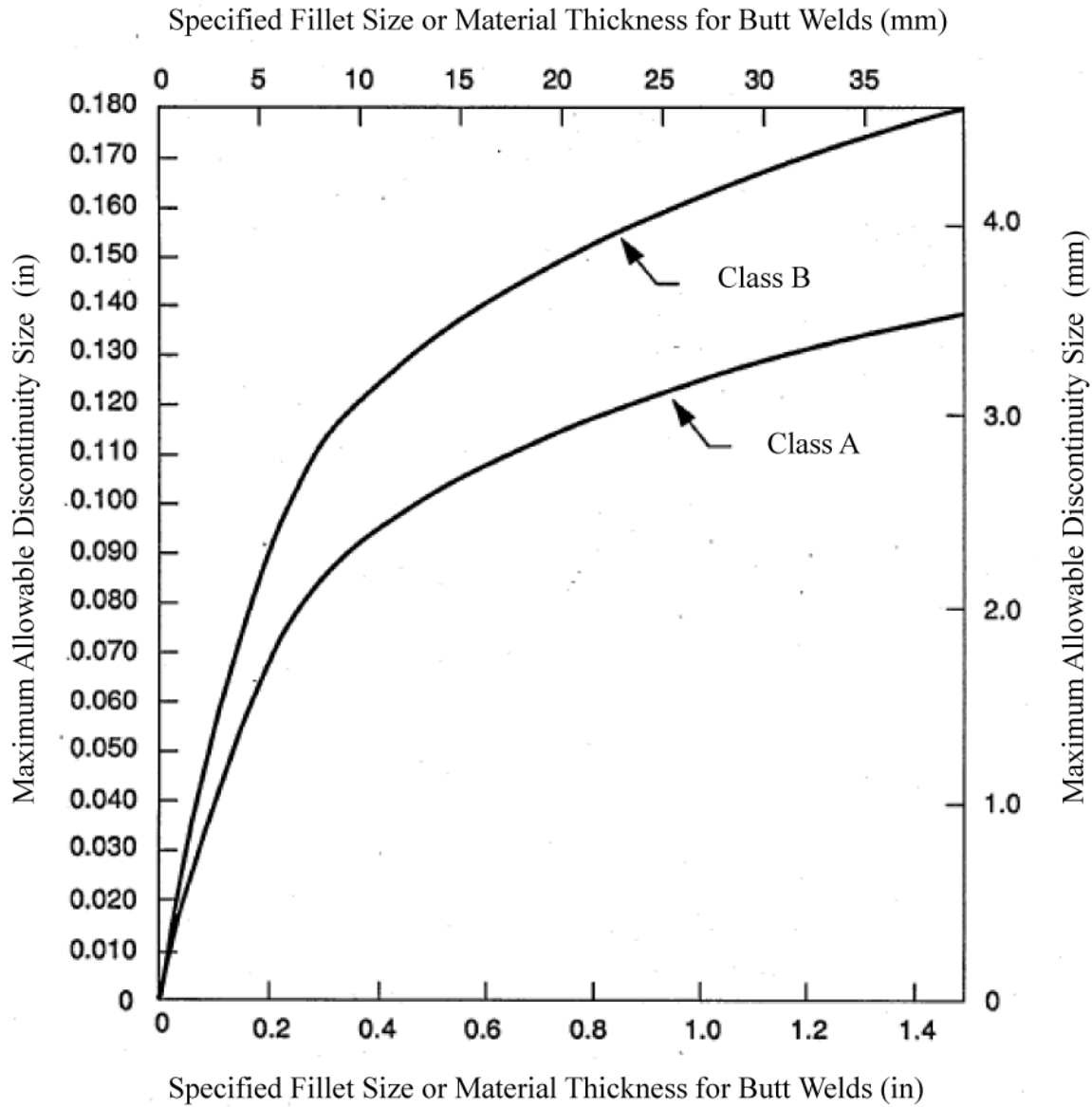

Figure 26. Internal Defects for Aluminum Alloys

CHECK THE MASTER LIST – VERIFY THAT THIS IS CORRECT VERSION BEFORE
USE

MSFC Technical Standard EM30		
Title: Process Specification – Welding Aerospace Hardware	Document No.: MSFC-SPEC-3679	Revision: A
	Effective Date: October 22, 2018	Page 71 of 92

Table XVI. Surface and Volumetric Acceptance Criteria – Steels, Heat Resistant Alloys

Process	Discontinuity	Class A, in [mm]	Class B, in [mm]	Class C, in [mm]
All	Cracks	None allowed	None allowed	None allowed
	Overlap (cold lap)	None allowed	None allowed	None allowed
	Incomplete fusion	None allowed	None allowed	None allowed
	Incomplete penetration	None allowed	None allowed	None allowed for full-penetration welds
	Undercut, concavity, lack of fill, suckback	None allowed where it occurs as a sharp notch or where the depth reduces the material thickness below drawing requirements	None allowed where it occurs as a sharp notch or where the depth reduces the material thickness below drawing requirements	None allowed where it occurs as a sharp notch or where the depth reduces the material thickness below drawing requirements
Fusion	Surface porosity and inclusions	NAS 1514 Class I	NAS 1514 Class II	NAS 1514 Class III
	Internal quality	NAS 1514 Class I	NAS 1514 Class II	NAS 1514 Class III
Electron Beam	Undercut and concavity	Sharp crevice at root - reject		
		Thin weldment below minimum drawing requirements - reject		
		Exceed a depth of 0.05t or 0.040 [1], whichever is less - reject		
		Exceed a width of 0.25t or 0.080 [2], whichever is less - reject		
		Exceed a length of 0.5 [12.7] for any single indication or a total of 1.5 [38.1] in any 6 [152] length - reject		
	Porosity	See Figure 27.		
	Pore clusters	Clusters of two or more pores are acceptable, provided the clusters may be enclosed within a circle of diameter equal to or less than the maximum pore size allowed.	Clusters of two or more pores are acceptable, provided the clusters may be enclosed within a circle of diameter equal to or less than the maximum pore size allowed.	N/A

CHECK THE MASTER LIST – VERIFY THAT THIS IS CORRECT VERSION BEFORE
USE

MSFC Technical Standard EM30		
Title: Process Specification – Welding Aerospace Hardware	Document No.: MSFC-SPEC-3679	Revision: A
	Effective Date: October 22, 2018	Page 72 of 92

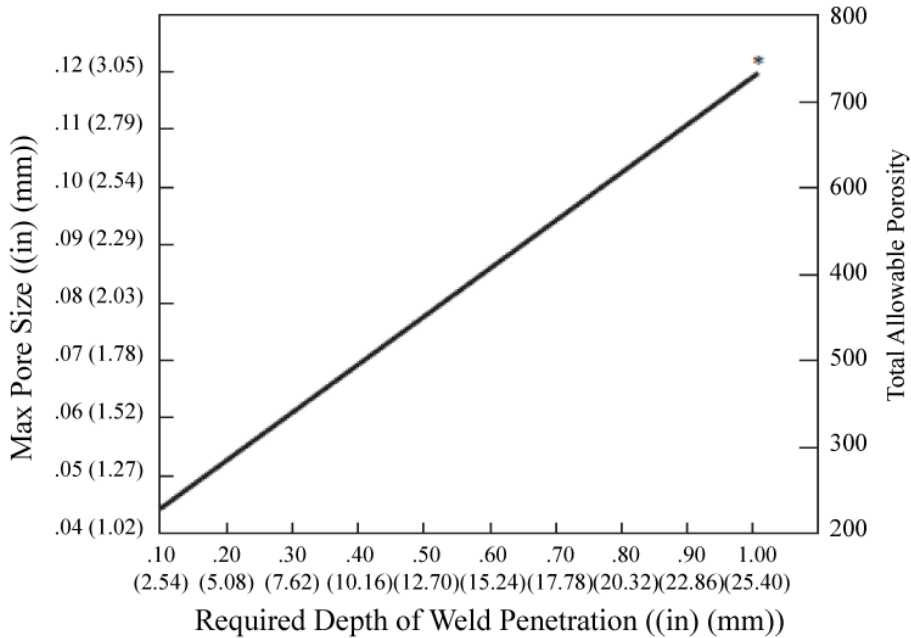
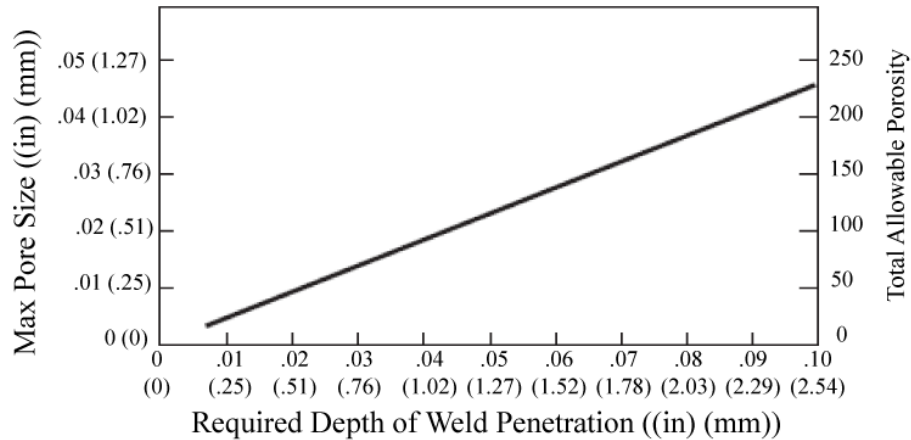

*For depth of penetration (DOP) greater than 1.00 in (25.4 mm):

- max pore size is .12 in (3.05 mm)
- total porosity index is 750 x DOP

Figure 27. EBW Porosity Acceptance Criteria for Steels, Heat Resistant

Table XVII. Weld Surface and Volumetric Acceptance Criteria – Titanium Alloys

Discontinuity	Class A	Class B	Class C
Cracks	None allowed	None allowed	None allowed
Overlap (cold lap)	None allowed	None allowed	None allowed
Incomplete fusion	None allowed	None allowed	None allowed
Incomplete penetration	None allowed	None allowed	None allowed
Porosity	NAS 1514 Class I	NAS 1514 Class II	NAS 1514 Class III

CHECK THE MASTER LIST – VERIFY THAT THIS IS CORRECT VERSION BEFORE
USE

MSFC Technical Standard EM30		
Title: Process Specification – Welding Aerospace Hardware	Document No.: MSFC-SPEC-3679	Revision: A
	Effective Date: October 22, 2018	Page 73 of 92

Appendix E Weld Procedure Specification Information

E.1 PURPOSE AND/OR SCOPE

The purpose of this appendix is to provide guidance. It contains information of a general or explanatory nature but does not contain requirements.

E.2 RECOMMENDED PARAMETERS TO BE RECORDED IN WPS

Table XVIII recommends parameters to be recorded in a WPS and contains information of a general or explanatory nature but does not contain requirements.

Table XVIII. Recommended Parameters to be Recorded in a WPS

Electron Beam Welding	Fusion (Automatic and Mechanized)	Fusion (Manual and Semi- Automatic)	Friction Stir Welding	Friction Plug Welding
Base metal alloys	Base metal alloys	Base metal alloys	Base metal alloys	Base metal alloys
Base metal thickness(es)	Base metal thickness(es)	Base metal thickness(es)	Base metal thickness	Base metal thickness(es)
Base metal heat treat condition(s)	Base metal heat treat condition(s)	Base metal heat treat condition(s)	Base metal heat treat condition(s)	Base metal heat treat condition(s)
Joint configuration	Joint configuration	Joint configuration	Joint configuration	Joint configuration
Weld position	Weld position	Weld position	Penetration ligament	Weld position
Start-up parameters	Start-up parameters	Start-up parameters	Start-up parameters	Start-up parameters
Surface preparation at weld joint	Joint preparation method	Joint preparation method	Joint preparation method	Joint preparation method
Tacking passes and parameters	Tacking passes and parameters	Tacking passes and parameters	Tacking passes and parameters	Backing plate/button drawing number
Preweld cleaning procedure or specification or both	Preweld cleaning procedure or specification or both	Preweld cleaning procedure or specification or both	Preweld cleaning procedure or specification or both	Preweld cleaning procedure or specification or both
Procedure qualification number	Procedure qualification number	Procedure qualification number	Procedure qualification number	Procedure qualification number
Filler metal type and specification	Wire alloy and size	Weld filler metal type and diameter	Plunge Load	Plug design
High voltage ($\pm 5\%$)	Wire speed (ipm)	Wire speed (ipm)	Travel speed	Travel speed
Beam current ($\pm 5\%$)	Weld type	Weld process	Spindle speed	Spindle speed
Welding Speed ipm [mm/sec] ($\pm 5\%$)	Travel speed	Tungsten type, size, and configuration	Joint designation	Forge time
Filler wire feed speed ($\pm 10\%$)	Tungsten size, type, configuration, and tolerances	Target values for amps, volts, and travel speed	Pin tool part number, material, or drawing number	Forge load
Focusing current ($\pm 5\%$)	Tungsten extension	Tungsten extension	Torque range	Heating load
Number of passes and sequence	Number of passes and sequence	Number of passes and sequence	Heel plunge	Heating displacement
Welding vacuum pressure (torr)	Welding current	Current polarity	Indicate force or position control	Plug alloy

CHECK THE MASTER LIST – VERIFY THAT THIS IS CORRECT VERSION BEFORE
USE

MSFC Technical Standard EM30		
Title: Process Specification – Welding Aerospace Hardware	Document No.: MSFC-SPEC-3679	Revision: A
	Effective Date: October 22, 2018	Page 74 of 92

Electron Beam Welding	Fusion (Automatic and Mechanized)	Fusion (Manual and Semi-Automatic)	Friction Stir Welding	Friction Plug Welding
Sketch of setup, including all angles (± 0.5 deg), MAX gap	Welding current type	Range on power supply	Shoulder part number, material, or drawing number	Computer program name/number
EBW certification number	Times for straight and reverse current	Power supply	Pin length	
Operator and ID stamp	Arc voltage	Maximum gap allowance	Root face or surface coating	
Gun to work distance ± 0.125 in [± 3 mm]	Power supply ampere range	Shield gas type and flow rate	Root opening (or gap)	
Cathode to anode spacer	Power supply	Backside shielding gas type and flow rate	Weld fixture drawing number	
Beam deflection <u>on</u> <u>off</u>	Power supply mode selection	Shield cup/nozzle size	Weld schedule	
Computer program name/number	Shield gas type and flow rate	Torch	Centerline offset	
Nugget dimensions in accordance with Figure 6	Backside shielding gas type and flow rate	Torch lead angle	Traverse load	
Dimensions of starting weld tab and run off tab plates	Shield cup/nozzle size		Lead angle	
Termination parameters	Computer program name/number		Axial load	
	Torch lead angle		MAX plunge force	
	Start slope current and time		MAX plunge speed	
	Tail slope current and time		Specific tapered thicknesses, if a tapered thickness is being welded	
	Oscillation dwell, width, and speed		Machine model and serial numbers	
	Torch		Grain direction	
	Termination parameters		Dwell time	
			Direction of tool rotation	
			Anvil material	
		Clamp pressure		
		Termination parameters		

CHECK THE MASTER LIST – VERIFY THAT THIS IS CORRECT VERSION BEFORE USE

MSFC Technical Standard EM30		
Title: Process Specification – Welding Aerospace Hardware	Document No.: MSFC-SPEC-3679	Revision: A
	Effective Date: October 22, 2018	Page 75 of 92

Appendix F Recommended Weld Filler Metals

F.1 PURPOSE AND/OR SCOPE

This purpose of this appendix is to provide guidance. It contains information of a general or explanatory nature but does not contain requirements.

F.2 TABLES

Table XIX thru Table XXIV present recommended filler alloys for various metal combinations.

Table XIX. Filler Alloys Recommended for Aluminum Alloys and Combinations

Base Alloy	2014	2219	2195	5052	6061 ¹	5456
2014	4043, 2319				4043	
2219	2319, 4043	2319	4043, 2319		4043	
2195		4043, 2319	4043			
5052				5356	4043	
6061 ¹	4043	4043		4043	4043	
5456	4043, 5356	4043, 5356		5356, 5556	4043, 5356	5356, 5556

¹Unless specified otherwise, filler metal shall be used when fusion welding 6061.

MSFC Technical Standard EM30		
Title: Process Specification – Welding Aerospace Hardware	Document No.: MSFC-SPEC-3679	Revision: A
	Effective Date: October 22, 2018	Page 76 of 92

Table XX. Filler Alloys Recommended for Carbon and Low Alloy Steels and Combinations

Base Alloy	Mild Steels	Construction Steels	4130	4135, 4140	4335, 4340	T1	9Ni 4Co	18-7 Maraging Steel (250)
Mild Steels	GA65	NAX 9115	Vac Melt 17-22AS	Vac Melt 17-22AS	Vac Melt 17-22AS, GA65	Vac Melt 17-22AS, GA65		
Construction Steels		NAX 9115	Vac Melt 17-22AS	Vac Melt 17-22AS	Vac Melt 17-22AS, GA65	Vac Melt 17-22AS, GA65		
4130			Vac Melt 17-22AS	Vac Melt 17-22AS	Vac Melt 17-22AS	Vac Melt 17-22AS		
4135, 4140				Vac Melt 17-22AS	Vac Melt 17-22AS	Vac Melt 17-22AS		
4335, 4340					Vac Melt 17-22AS	Vac Melt 17-22AS		
9Ni 4Co							HP 9-4-.2	
18-7 Maraging Steel (250)								18-7 Maraging Steel
Hastelloy C						Hastelloy W		
304, 310, 321, 347	Inconel 82	Inconel 82				Inconel 92		

CHECK THE MASTER LIST – VERIFY THAT THIS IS CORRECT VERSION BEFORE USE

MSFC Technical Standard EM30		
Title: Process Specification – Welding Aerospace Hardware	Document No.: MSFC-SPEC-3679	Revision: A
	Effective Date: October 22, 2018	Page 77 of 92

Table XXI. Filler Alloys Recommended for Stainless Steels and Combinations

Base Alloy	304, 304L	310	316, 316L	321, 347	410	430	19-9DL,19- 9DX	17-4 PH	17-7 PH
304 , 304L	308L	308L	316L	308L			349	Hastelloy W	Hastelloy W
310		310	310	310			349	Hastelloy W	Hastelloy W
316, 316L			316L	347			Inconel 92	Hastelloy W	Hastelloy W
321, 347				321, 347		Hastelloy W	349	Hastelloy W	Hastelloy W
410					410	430			
430						430			
19-9DL, 19-9DX							349	Hastelloy W	Hastelloy W
17-4 PH								17-4 PH	17-7 PH
17-7 PH									17-7 PH
16-25-6									
21-6-9									
29-20 Cb									
29-9									
AM350									
AM355									
A-286									
Haynes 21									
Haynes 188	308L, Haynes 188	308L, Haynes 188							
Incoloy 903 Cartech CTX-1									
Invar 36									

CHECK THE MASTER LIST – VERIFY THAT THIS IS CORRECT VERSION BEFORE USE

MSFC Technical Standard EM30		
Title: Process Specification – Welding Aerospace Hardware	Document No.: MSFC-SPEC-3679	Revision: A
	Effective Date: October 22, 2018	Page 78 of 92

Table XXI. Filler Alloys Recommended for Stainless Steels and Combinations (continued)

Base Alloy	16-25-6	21-6-9	29-20 Cb	29-9	AM350	AM355	A-286	Incoloy 903 Cartech CTX-1	Invar 36
304, 304L	Hastelloy W	308L 36% Nickel	29.20 Cb		AM350	AM355			Hastelloy W
310	Hastelloy W	308L	29.20 Cb		AM350	AM355			Hastelloy W
316, 316L	Hastelloy W	308L	29.20 Cb		Inconel 92	Inconel 92			Hastelloy W
321, 347	Hastelloy W	308L 36% Nickel	29.20 Cb		AM350	AM355	Hastelloy W		Hastelloy W
410									
430									
19-9DL, 19-9DX									
17-7 PH									
16-25-6	349			312					
21-6-9		ARMCO 21-6-9					Hastelloy W		
29-20 Cb			29.20 Cb		AM355	AM355			
29-9				312					
AM350					AM350	AM350			
AM355						AM355			
A-286							A-286		
Haynes 21	Hastelloy W								
Haynes 188		Haynes 188							
Incoloy 903 Cartech CTX-1								Incoloy 903	
Invar 36									36% Nickel Hastelloy W

CHECK THE MASTER LIST – VERIFY THAT THIS IS CORRECT VERSION BEFORE USE

MSFC Technical Standard EM30		
Title: Process Specification – Welding Aerospace Hardware	Document No.: MSFC-SPEC-3679	Revision: A
	Effective Date: October 22, 2018	Page 79 of 92

Table XXII. Filler Alloys Recommended for Nickel- and Cobalt-Base Alloys and Combinations

Base Alloy	Ni200 Ni270	ED Nickel	Monel 400	K-Monel 500	Inconel 600	Inconel X 750	Inconel 718	Inconel 625	Hastelloy B	Hastelloy C	Hastelloy X
Ni200 Ni270	Nickel 61	Nickel 61	Nickel 61	Nickel 61					Hastelloy W	Hastelloy W	Hastelloy W
ED Nickel	Nickel 61	Nickel 61	Nickel 61		Nickel 61	Nickel 61	Nickel 61	Nickel 61	Nickel 61	Nickel 61	Nickel 61
Monel 400			Monel 60	Monel 60							
Inconel 600					Inconel 82	Hastelloy W	Hastelloy W	Hastelloy W	Hastelloy W	Hastelloy W	Hastelloy W
Inconel X 750						Inconel 69	Inconel 718, Hastelloy W	Hastelloy W	Hastelloy W	Hastelloy W	Hastelloy W
Inconel 718							Inconel 718	Inconel 625	Hastelloy W	Hastelloy W	Hastelloy W
Inconel 625								Inconel 625	Inconel 625	Inconel 625	Inconel 625
Hastelloy B									Hastelloy B	Hastelloy W	Hastelloy W
Hastelloy C										Hastelloy C	Hastelloy W
Hastelloy X											Hastelloy X
Haynes 21											
Haynes 25 L-605											
Haynes 188											
Haynes 230											
Rene' 41											
Incoloy 800											
Incoloy 88											
4130, 4140					Inconel 92		Hastelloy W			Hastelloy W	
4340							Inconel 92				
304L, 347, 321, 316L, 310	Inconel 92				Inconel 625, Hastelloy W	Hastelloy W	Inconel 625, Hastelloy W	Inconel 625	Hastelloy W	Hastelloy W	Hastelloy W

CHECK THE MASTER LIST – VERIFY THAT THIS IS CORRECT VERSION BEFORE USE

MSFC Technical Standard EM30		
Title: Process Specification – Welding Aerospace Hardware	Document No.: MSFC-SPEC-3679	Revision: A
	Effective Date: October 22, 2018	Page 80 of 92

Table XXII. Filler Alloys Recommended for Nickel- and Cobalt-Base Alloys and Combinations (continued)

Base Alloy	Haynes 21	Haynes 25 L-605	Haynes 188	Haynes 230	Rene' 41	Incoloy 800	Incoloy 88	Incoloy 903 Cartech CTX-1	21-6-9
Ni200, Ni270	Hastelloy W	Hastelloy W	Hastelloy W						
ED Nickel	Nickel 61	Nickel 61	Nickel 61		Nickel 61				
Monel 400									
Inconel 600	Hastelloy W	Hastelloy W	Hastelloy W		Hastelloy W				
Inconel X 750	Hastelloy W	Hastelloy W			Hastelloy W				
Inconel 718	Hastelloy W	Hastelloy W	Haynes 188			Incoloy 88	Incoloy 88	Incoloy 903	Inconel 625, Incoloy 88
Inconel 625	Inconel 625	Inconel 625	Inconel 625		Inconel 625		Inconel 625, Incoloy 88	Inconel 625	Inconel 625, Incoloy 88
Hastelloy B	Hastelloy W	Hastelloy W	Haynes 188						
Hastelloy C	Hastelloy C	Hastelloy W	Haynes 188						
Hastelloy X	Hastelloy W	Hastelloy W	Hastelloy W						
Haynes 21	Haynes 25	Haynes 25	Haynes 188						
Haynes 25 L-605		Haynes 25	Haynes 188						
Haynes 188			Haynes 188		Haynes 188		Haynes 188		Haynes 188
Haynes 230				Haynes 230					
Rene' 41					Hastelloy W, Rene' 41				
Incoloy 800						Incoloy 88			
Incoloy 88							Incoloy 88, Incoloy 903, Haynes 188		
4130, 4140									
4340									
304L, 347, 321, 316L, 310	Hastelloy W	Hastelloy W	Haynes 188				Hastelloy W		

CHECK THE MASTER LIST – VERIFY THAT THIS IS CORRECT VERSION BEFORE USE

MSFC Technical Standard EM30		
Title: Process Specification – Welding Aerospace Hardware	Document No.: MSFC-SPEC-3679	Revision: A
	Effective Date: October 22, 2018	Page 81 of 92

Table XXIII. Filler Alloys Recommended for Copper Alloys and Combinations

Base Alloy	OFCH Copper	Deoxidized Copper	Amzirc	Narloy A	Narloy Z
OFCH Copper	Deoxidized Copper	Deoxidized Copper Silicon Bronze	Deoxidized Copper	Deoxidized Copper	Deoxidized Copper
Deoxidized Copper		Deoxidized Copper	Deoxidized Copper	Deoxidized Copper	Deoxidized Copper
Amzirc			Deoxidized Copper	Deoxidized Copper	Deoxidized Copper
Narloy A				Deoxidized Copper	Deoxidized Copper
Narloy Z					Deoxidized Copper

Note: Deoxidized copper is used for maximum thermal conductivity. It has low strength.

Table XXIV. Filler Alloys Recommended for Titanium Alloys and Combinations

Base Alloy	CP Titanium	5Al-2.5Sn	5Al-2.5Sn ELI	6Al-4V	6Al-4V ELI	3Al-2.5V
CP Titanium	CP Titanium					
5Al-2.5Sn	CP Titanium	Ti 5Al-2.5Sn, Ti 5Al-2.5Sn ELI				
5Al-2.5Sn ELI	CP Titanium	Ti 5Al-2.5Sn, Ti 5Al-2.5Sn ELI	Ti 5Al-2.5Sn ELI			
6Al-4V	Ti 6Al-4V, Ti 6Al-4V ELI	Ti 6Al-4V, Ti 6Al-4V ELI	Ti 5Al-2.5Sn ELI Ti 6Al-4V, Ti 6Al-4V ELI	Ti 6Al-4V, Ti 6Al-4V ELI	Ti 6Al-4V, Ti 6Al-4V ELI	
6Al-4V ELI		Ti 6Al-4V ELI	Ti 6Al-4V ELI	Ti 6Al-4V, Ti 6Al-4V ELI	Ti 6Al-4V ELI	
3Al-2.5V				Ti 6Al-4V, Ti 6Al-4V ELI, Ti 3Al-2.5V	Ti 6Al-4V, Ti 6Al-4V ELI, Ti 3Al-2.5V	Ti 3Al-2.5V

CHECK THE MASTER LIST – VERIFY THAT THIS IS CORRECT VERSION BEFORE USE

MSFC Technical Standard EM30		
Title: Process Specification – Welding Aerospace Hardware	Document No.: MSFC-SPEC-3679	Revision: A
	Effective Date: October 22, 2018	Page 82 of 92

Appendix G Preweld and Postweld Cleaning Methods

G.1 PURPOSE AND/OR SCOPE

The purpose of this appendix is to provide preweld and postweld requirements.

G.2 PREWELD AND POSTWELD CLEANING METHODS

Table XXV lists preweld and postweld cleaning methods for various alloys.

Table XXV. Acceptable Preweld and Postweld Cleaning Methods

Alloy	Method							
	Degrease by Alkaline Wash	Chemical Descale	Chemical Deoxidize	Hand Scrape / Draw File	Hand Grind / Sand	Hand Wire Brush ¹	Scotch- Brite™ Abrasion ²	Hand Solvent Wipe
Aluminum Alloys	X	X	X	X		X	X	X
Copper Alloys	X		X	X	X	X	X	X
Nickel- Based Alloys	X			X	X	X	X	X
Chromium- Based Alloys ³ Stainless Steels	X	X	X		X	X	X	X
Titanium Alloys ⁴	X		X	X		X	X	X
Carbon	X	X			X	X	X	X

¹Stainless steel wire brushes only.

²Use only coated abrasive and Scotch-Brite™ Roloc™ products.

³Do not use chlorinated solvents.

⁴Do not use chlorinated or halogenated solvents.

CHECK THE MASTER LIST – VERIFY THAT THIS IS CORRECT VERSION BEFORE USE

MSFC Technical Standard EM30		
Title: Process Specification – Welding Aerospace Hardware	Document No.: MSFC-SPEC-3679	Revision: A
	Effective Date: October 22, 2018	Page 83 of 92

Appendix H Reference Documents

H.1 PURPOSE AND/OR SCOPE

This purpose of this appendix is to list the specifications used in the development of this process specification. This appendix contains information of a general or explanatory nature but does not contain requirements.

H.2 GOVERNMENT DOCUMENTS

NASA George C. Marshall Space Flight Center

MPR 8730.5	Metrology and Calibration
MSFC-SPEC-504C	Specification: Welding, Aluminum Alloys
MSFC-SPEC-560A	The Fusion Welding of Steels, Corrosion and Heat Resistant Alloys
MSFC-SPEC-766	Fusion Welding Titanium and Titanium Alloys
MWI 3410.5	Personnel Certification Program for Skills

Military

MIL-STD-961	Defense and Program-Unique Specifications Format and Context
-------------	--

H.3 NON-GOVERNMENT DOCUMENTS

AWS

AWS C6.2	Specification for Friction Welding of Metals
AWS D17.1	Specification for Fusion Welding for Aerospace Applications
AWS D17.2	Specification for Resistance Welding for Aerospace Applications
AWS D17.3	Specification for Friction Stir Welding of Aluminum Alloys for Aerospace Applications

NAS

NAS 976	Electron Beam Welding Machine – High Vacuum
NAS 1514	Radiographic Standard for Classification of Fusion Weld Discontinuities

CHECK THE MASTER LIST – VERIFY THAT THIS IS CORRECT VERSION BEFORE USE

MSFC Technical Standard EM30		
Title: Process Specification – Welding Aerospace Hardware	Document No.: MSFC-SPEC-3679	Revision: A
	Effective Date: October 22, 2018	Page 84 of 92

ASME

ASME B46.1 Surface Texture Roughness, Waviness and Lay

SAE/AMS

AMS 2680 Electron-Beam Welding for Fatigue Critical Applications

AMS 2681 Electron-Beam Welding

Lockheed Martin Space Systems Company, Michoud Operations

STP 5511F Friction Stir Welding (FSW) of Longitudinal Barrel Welds

STP 5507P Fusion Welding of 2195 Aluminum-Lithium Alloy

STP 5508W Plasma Arc (VPPA) Welding of 2195 Aluminum-Lithium Alloy

STP 5506L Plasma Arc (VPPA) Welding of 2219 Aluminum

STP 5509N Soft Plasma Arc Welding (SPAW) of 2195 Aluminum-Lithium Alloy

STP 5501T Fusion Welding of 2219 Aluminum

STP 5510A Friction Plug Weld (FPW) Repair

Aerojet Rocketdyne

RL10011 Fusion Welding for SSME; Process and Quality Requirements

RA1607-071 C Requirements of Electron Beam Welding, SSME

MSFC Technical Standard EM30		
Title: Process Specification – Welding Aerospace Hardware	Document No.: MSFC-SPEC-3679	Revision: A
	Effective Date: October 22, 2018	Page 85 of 92

Appendix I Acronyms and Definitions

I.1 ACRONYMS / ABBREVIATIONS

This purpose of this appendix is to list the acronyms, abbreviations and definitions used in this process specification. This appendix contains information of a general or explanatory nature but does not contain requirements.

Acronyms

AMS	Aerospace Material Specification
ASTM	American Society for Testing and Materials, “ASTM, International”
AWS	American Welding Society
Btu	British thermal unit
C-FSW	Conventional-Friction Stir Welding
CO ₂	Carbon Dioxide
DA	Direct Aged
DOP	Depth of Penetration
EBW	Electron Beam Welding
ELI	Extra Low Interstitial
FPW	Friction Plug Welding
FPPW	Friction Pull Plug Welding
FSW	Friction Stir Weld, Friction Stir Welding
FusPW	Fusion Plug Welding
GTAW	Gas Tungsten Arc Welding
HDBK	Handbook
LBW	Laser Beam Welding
LH ₂	Liquid Hydrogen
LO ₂ (LOX)	Liquid Oxygen
LOP	Lack of Penetration
MIL	Military
MPCV	Multi-purpose crew vehicle
MPR	Marshall Procedural Requirements
MRB	Material Review Board
MSFC	Marshall Space Flight Center
MUA	Materials Usage Agreement
N/A	Not Applicable
NAS	National Aerospace Standards
NASA	National Aeronautics and Space Administration
NDE	Nondestructive Examination
NIST	National Institute of Standards and Technology
NPR	NASA Procedural Requirements
PAW	Plasma Arc Welding
POD	Probability of Detection
PQR	Procedure Qualification Record

CHECK THE MASTER LIST – VERIFY THAT THIS IS CORRECT VERSION BEFORE USE

MSFC Technical Standard EM30		
Title: Process Specification – Welding Aerospace Hardware	Document No.: MSFC-SPEC-3679	Revision: A
	Effective Date: October 22, 2018	Page 86 of 92

PRF	Performance (Specification)
RPM	Revolutions per Minute
RPT	Retractable Pin Tool
SAE	Society of Automotive Engineers, International
SHE	Safety, Health, And Environmental
SI	System International or metric system of measurement
SMA	Safety and Mission Assurance
SPAW	Soft Plasma Arc Welding
SR-FSW	Self Reacting-Friction Stir Welding
SSE	System Safety Engineering
SSME	Space Shuttle Main Engine
STA	Solution Treated Aged
STD	Standard
TMAZ	Thermo-Mechanically Affected Zone
USP	United States Pharmacopeia
VPPA	Variable Polarity Plasma Arc
WCWJ	Worst Case Weld Joint
WPQ	Welder Performance Qualification
WPS	Weld Procedure Specification

Symbols

R	Reinforcement (Crown)
R'	Reinforcement (Root)
S	weld bead concavity
t	thickness of thinner joint member
T	thickness of thicker joint member
W'	maximum weld width (crown)
W"	maximum weld width (root)

I.2 DEFINITIONS

I.2.1 General Welding Definitions.

Unless otherwise defined in this process specification, welding terms, definitions, and symbols may conform to AWS A2.4 and AWS A3.0. For additional definitions reference AWS A3.0.

2-for-1 Replacement: The practice of replacing a procedure qualification panel that does not meet specification requirements with two panels welded with identical parameters; this practice is only used when the original panel failed the criteria because of a processing error not associated with the weld parameters.

Anomaly: A deviation or irregularity.

Certified: Describing a welder (operator) or inspector who passes qualification tests based on requirements established in this process specification or term describing a weld procedure that passes qualification tests based on requirements established in this process specification.

CHECK THE MASTER LIST – VERIFY THAT THIS IS CORRECT VERSION BEFORE USE

MSFC Technical Standard EM30		
Title: Process Specification – Welding Aerospace Hardware	Document No.: MSFC-SPEC-3679	Revision: A
	Effective Date: October 22, 2018	Page 87 of 92

Chill Bar: A steel, aluminum, or copper bar that limits distortion by limiting the heat flow from a weld joint.

Concave Root Surface: A weld root with penetration not extending beyond the thickness of the base metal; sometimes referred to as “suckback.”

Confidence Panel/Weld: A full-scale, high-fidelity weld made in production tooling with procedures and parameters intended for flight hardware; can be nondestructively and destructively tested to validate the production weld procedure.

Critical Defect: A defect that adversely affects the weld properties, causing the weld not to perform as designed, resulting in failure of the weld joint.

Cross-Slide: Travel perpendicular to the weld direction along the surface of the hardware.

Deburred: Having had the thin ridge or area of roughness produced in cutting or shaping metal removed.

Degaussed: Made effectively nonmagnetic by means of electrical coils carrying currents that neutralize the magnetism of a metal object.

Essential Variables: Weld process parameters that influence directly the weld process and resulting weld properties; examples include but are not limited to heat input, travel speed, torch setup, pin tool configuration.

Fail Safe: A condition where a redundant load path exists within a part (or hardware), so that after loss of any single individual load path, the remaining load path(s) have sufficient structural capability to withstand the redistributed loads, and the loss of the load path will not cause a catastrophic hazard.

Heat Input: Quantity of energy introduced per unit length of weld from a traveling heat source, expressed in British thermal units per inch (Btu/in) [joules per millimeter (J/mm)]. Computed as the ratio of the total input power of the heat source in watts (W) (Btu/second (sec)) to the travel velocity in inches per second (in/sec) or millimeters per second (mm/sec).

Heat-Sensitive Alloys: Alloys that require mechanical working, precipitation strengthening, or other metallurgical mechanisms to obtain their rated strength, if exposure to the heat input from the welding process reduces or eliminates this strengthening mechanism in proximity of the weld.

In-Process Correction: Action taken by a welder to complete a process before submittal to inspection.

Incomplete Joint Penetration: A weld depth (extending from its face into the joint, exclusive of reinforcement) that is less than the joint thickness.

Lack of Fill: A weld face surface not extending beyond the thickness of the base metal.

Material Review Board (MRB): A cross-functional group that reviews production or purchased items on hold because of nonconformance or usability concerns and that determines their disposition, which may include repair, rework, scrap, or return to the vendor.

CHECK THE MASTER LIST – VERIFY THAT THIS IS CORRECT VERSION BEFORE USE

MSFC Technical Standard EM30		
Title: Process Specification – Welding Aerospace Hardware	Document No.: MSFC-SPEC-3679	Revision: A
	Effective Date: October 22, 2018	Page 88 of 92

Material Thickness: The minimum material thickness of a joint member in accordance with drawing tolerance; the thinner of the joint members with different thicknesses is designated "t."

NASA Technical Authority: An individual or group authorized by the contracting agency to address technical matters and who is responsible for the interpretations and implementations of the requirements set forth in this specification.

Nonstructural Weld: A non-load-bearing weld.

Pathfinder: High-fidelity demonstration weld before first production article; last item to be welded before first production article.

Peaking: The angular distortion of the components resulting from welding; calculated as the angle resulting from the intersection of tangents taken from the surface of the two components being welded.

Peening: The surface working of metal by means of mechanical, thermal, or acoustic methods. Most commonly accomplished through repeated blows of impelled shot or a round-nose tool.

Planishing: Mechanical working of weld metal by rolling in a mill or through a rapid succession of blows delivered by highly polished dies or hammers.

Pressure Vessel: A container designed primarily for pressurized storage of gases or liquids and that also performs any of the following:

- Contains stored energy of 19,307 J (14,240 ft-lb) or greater based on adiabatic expansion of a perfect gas.
- Stores a gas that will experience an MDP greater than 690 kPa (100 psia).
- Contains a gas or liquid in excess of 103 kPa (15 psia) that will create a catastrophic hazard if released.

Pressurized Component: A line, fitting, valve, regulator, etc., that is part of a pressurized system intended primarily to sustain a fluid pressure and fluid transfer. Any piece of hardware that is not a pressure vessel or a pressurized fluid container but is pressurized via a pressurization system.

Pressurized Structure: A hardware item designed to carry both internal pressure and vehicle structural loads.

Proficiency Demonstration: Demonstration of a welder's or welding operator's ability to produce welds meeting prescribed standards.

Qualified: A term describing a welder (operator) who has demonstrated adequacy to meet prescribed requirements or describing a procedure that has demonstrated adequacy to meet prescribed requirements.

Qualified Inspector: A certified individual with the responsibility and ability to judge the quality of the welded specimens in relation to a written specification.

MSFC Technical Standard EM30		
Title: Process Specification – Welding Aerospace Hardware	Document No.: MSFC-SPEC-3679	Revision: A
	Effective Date: October 22, 2018	Page 89 of 92

Quantitative Nondestructive Examination (NDE): Examination of parts for flaws using established and standardized inspection techniques that are harmless to hardware, such as radiography, penetrant, ultrasonic, magnetic particle, and eddy current. The flaw detection capability of the inspection technique is statistically based; generally with a 90% POD at a 95% confidence level.

Repair: A procedure that makes a nonconforming item acceptable for use. The purpose of the repair is to reduce the effect of the nonconformance. Repair is distinguished from rework in that the characteristics after repair still do not completely conform to the applicable drawings, specifications, or contract requirements. Nonstandard repair procedures are authorized by MRB action for use on a one-time basis only. All repairs require MRB approval before implementation.

Rework: A procedure applied to a nonconforming item that completely eliminates the nonconformance and results in a characteristic that conforms completely to the drawings, specifications, or contract requirements.

Sound Metal: Weld metal that is free from defects or flaws.

Suckback: A condition in which the weld face or root surface extends below the adjacent surface of the base metal; also called “concave root surface” or “underfill”.

Superalloy: An alloy that resists oxidation and can withstand high temperatures and stresses.

Tapered Welds: Weld joints that change in thickness along the length of the joint.

Tooling: Production machinery.

Total Porosity Index: The total amount of porosity in a single linear inch of weld. The porosity index shall be determined by summing the sizes of all individual pores including individual pores contained in a cluster, in that portion of weld. Pores of size less than 0.001 in shall be deemed to be 0.001 in. For convenience, each 0.001 in increment is assigned an index number of one (1). Thus a weld containing four pores, in a given linear inch, with sizes of 0.030 in, 0.020 in, 0.001 in and 0.0005 in, would have a total index of $30+20+1+1 = 52$.

Underthickness: The minimum material thickness of the thinnest joint member per drawing tolerance.

Weld Land: Thickened base metal at the weld joint.

Weld Zone: The weld metal fusion zone plus the heat-affected zone.

Worst Case Weld Joint: A weld panel representative of the extreme conditions of the joint fit-up requirements. Reference Appendix B.

MSFC Technical Standard EM30		
Title: Process Specification – Welding Aerospace Hardware	Document No.: MSFC-SPEC-3679	Revision: A
	Effective Date: October 22, 2018	Page 90 of 92

I.2.2 Friction Stir Welding (FSW) Definitions.

The following definitions apply specifically to the FSW process, illustrated in Figure 28 and Figure 29:

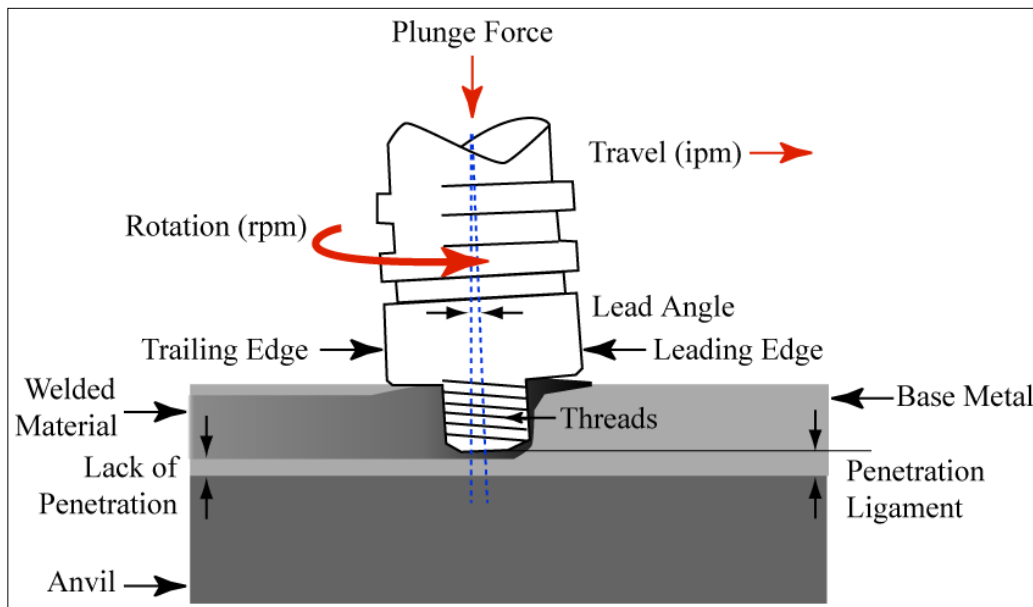

Figure 28. Conventional-Friction Stir Welding Process

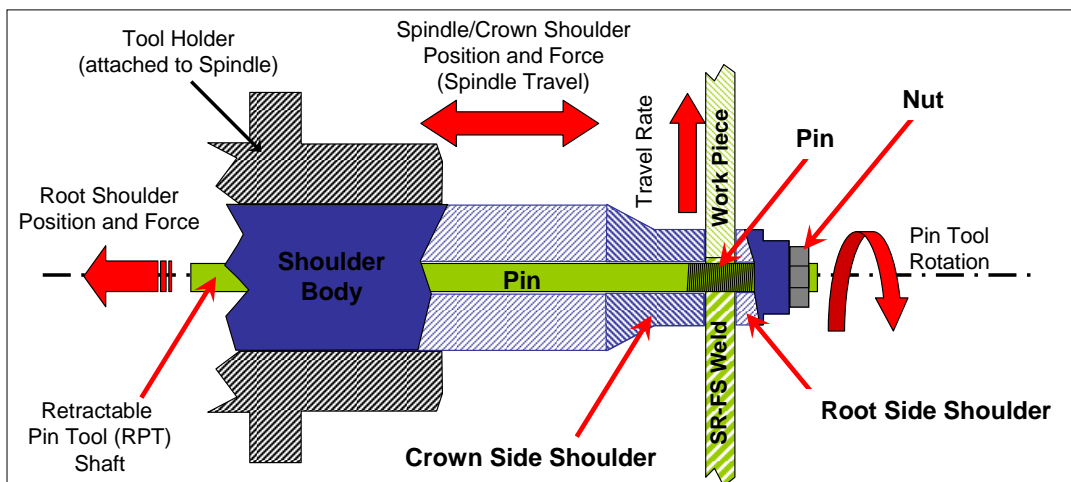

Figure 29. Self Reacting-Friction Stir Welding Process

Advancing Side: The side of the FS weld on which the local tangential velocity of the tool and the travel (translational) velocity of the tool are in the same direction; for dissimilar metal combinations, the joint designation follows the naming convention of advancing/retreating.

Anvil: A rigid surface used to keep the work piece stationary and to react the plunge force in C-FSW.

Backing Button/Plate: The anvil that reacts the load during friction plug push/pull welding.

CHECK THE MASTER LIST – VERIFY THAT THIS IS CORRECT VERSION BEFORE USE

MSFC Technical Standard EM30		
Title: Process Specification – Welding Aerospace Hardware	Document No.: MSFC-SPEC-3679	Revision: A
	Effective Date: October 22, 2018	Page 91 of 92

Centerline Offset: The distance from the theoretical center that the pin tool is offset toward either the advancing or retreating side.

Conventional-Friction Stir Welding (C-FSW): FSW in which the load is reacted by an anvil, as shown in Figure 28.

Forge Load: A compressive load applied to the weld during friction stir welding.

Forge Time: The time during which the forge load is applied.

Friction Plug Welding: A solid-state weld process made in a circular hole, commonly used to close-out a SR-FSW termination hole.

Gouge: A depression or groove on the surface of the metal in which some of the metal has been removed; similar to a scratch but usually larger and wider with a flat or concave bottom; may have a sharp burr or raised metal at the terminal end.

Heating Displacement/Burn Off: Terms used in friction plug pull welding, referring to the distance the plug is pulled through the material after initial contact with the part being welded.

Heating Load: The compressive load applied during the heating phase of friction plug welding.

Heel Plunge: The greatest distance the shoulder plunges below the surface of the material being joined during a weld; typically measured at the trailing edge of the shoulder.

Joint Line Remnant: Discontinuity consisting of a semi-continuous layer of oxide in the weld.

Lack of Fill / Surface Lack of Fill: A condition in which the weld face surface extends below the surface of the adjacent base metal; a continuous or intermittent surface void caused by insufficient FSW pin tool heel plunge depth.

Leading Edge: The edge of the pin tool that is instantaneously located in the position farthest forward along the weld in the direction of travel.

Penetration Ligament: The shortest distance between the anvil and the pin tip during a weld.

Pin (Probe): The threaded part of the tool; embedded below the surface of the workpiece.

Plunge Force: The necessary force to maintain a consistent heel plunge or penetration ligament.

Retreating Side: The side of the FSW on which the local tangential velocity of the tool and the travel (translational) velocity of the tool are in the opposite direction.

Self Reacting-Friction Stir Welding (SR-FSW): FSW process in which the anvil is replaced by a root side shoulder that reacts the crown shoulder load, squeezing the material between the crown and root shoulders, as shown in Figure 29.

Scratch: A groove formed in the surface of the metal. Metal is not always removed, but raised metal may be present on either side of the impression.

Shoulder: The part of the tool that rests directly on the surface of the workpiece.

Surface Galling: Damage that removes particles from the surface; caused by excessive pin tool rotation.

CHECK THE MASTER LIST – VERIFY THAT THIS IS CORRECT VERSION BEFORE USE

MSFC Technical Standard EM30		
Title: Process Specification – Welding Aerospace Hardware	Document No.: MSFC-SPEC-3679	Revision: A
	Effective Date: October 22, 2018	Page 92 of 92

Surface Tearing: Minute surface cracks caused by excessive pin tool rotation.

Thickness Offset: The difference in thickness of the two parts making up the weld joint.

Tool Mark: An impression or cut in the metal that generally occurs in a distinct pattern.

Trailing Edge: The edge of the pin tool that is instantaneously located in the position farthest back along the weld, in the direction of travel.

Traverse: To travel in the weld direction.

Traverse Load: The force necessary to push the tool along the workpiece joint during welding; depends on the weld pitch, pin tool geometry, workpiece thickness, and material alloy being welded.

Underthickness: The measured difference between the weld minimum thickness and the applicable reference thickness.

Weld Flash: Material pushed outward by the tool shoulder along the edges of the shoulder contact area. (Also occurs in FPW, inertia, and flash welding.)