

**QUICK RELEASE PINS
AND PIN TETHERS,
STANDARD FOR**

ENGINEERING DEVELOPMENT DIRECTORATE



KSC-STD-P-0006
March 20, 1995

**QUICK RELEASE PINS
AND PIN TETHERS,
STANDARD FOR**

Approved By: Walter T. Murphy
Walter T. Murphy
Director of Engineering Development

JOHN F. KENNEDY SPACE CENTER, NASA

TABLE OF CONTENTS

<u>Section</u>	<u>Title</u>	<u>Page</u>
1.	SCOPE	1
2.	APPLICABLE DOCUMENTS	1
2.1	Governmental	1
2.1.1	Specifications	1
2.1.2	Standards	2
2.1.3	Other Documents	3
2.2	Non-Governmental	3
2.3	Order of Precedence	3
3.	REQUIREMENTS	4
3.1	General	4
3.1.1	Facility Applicability	4
3.1.2	GSE Applicability	4
3.2	Types of Quick Release Pins	4
3.2.1	Positive Locking, Single Acting Pins	4
3.2.2	Positive Locking, Double Acting Pins	4
3.2.3	Detent Pins	4
3.2.4	Tethers	5
3.3	Materials	5
3.3.1	Pin Materials	5
3.3.1.1	Alloy Steel	5
3.3.1.2	Corrosion Resistant Steel	5
3.3.2	Tether Materials	5
3.4	Protective Finishes	5
3.4.1	Alloy Steel	5
3.4.2	Corrosion Resistant Steel	7
3.5	Pin Usage	7
3.5.1	Controlled Environments	7
3.5.2	Launch Environment	7
3.5.3	Uncontrolled Environments	7
3.6	Pin Characteristics	7
3.6.1	Pin Handles Permitted	7
3.6.2	Pin Handles Not Permitted	11
3.6.3	Pin Lengths	11
3.6.4	Pin Diameters	11

TABLE OF CONTENTS (cont)

<u>Section</u>	<u>Title</u>	<u>Page</u>
3.6.5	Substitution of Pins	15
3.6.5.1	Requiring Prior Engineering Approval	15
6.5.2	Not Requiring Engineering Approval	15
7	Tether Installation	15
7.1	Pin Preparation	15
7.2	Tether Attachment to Pin	15
7.3	Ring Handle Replacement	15
7.4	Tether Attachment to Structure	15
7.5	Tether Attachment Hardware	18
8	Design	18
8.1	Design Drawings	18
8.2	Design Considerations	18
	QUALITY ASSURANCE PROVISIONS	18
	PREPARATION FOR DELIVERY	19
	NOTES	19
1	Intended Use	19
2	Definitions	19
2.1	Controlled Environment	19
2.2	Deviation	19
2.3	Dissimilar Metals	19
2.4	Stress Corrosion Cracking	19
2.5	Uncontrolled Environment	19
PPENDIX A	ALLOYS WITH HIGH RESISTANCE TO STRESS CORROSION CRACKING	A-1
PPENDIX B	RESTRICTIONS ON THE USE OF CADMIUM PLATING	B-1

LIST OF ILLUSTRATIONS

<u>Title</u>	<u>Page</u>
Tether Sizes	6
Single Acting Quick Release Pins, "L" and "T" Handles ...	8
Single Acting Quick Release Pins, Button and Ring Handles	9
Double Acting Quick Release Pins, "L" and "T" Handles ...	10
Double Acting Quick Release Pins, Ring Handle	12
Detent Pin, Quick Release, "L" and "T" Handles	13
Detent Pin, Quick Release, Ring Handle	14
Tether Attachments to Structure, Direct Termination	16
Tether Attachments to Structure, Tab Termination	17

ABBREVIATIONS AND ACRONYMS

AISI	American Iron and Steel Institute
ASTM	American Society for Testing and Materials
DE	Engineering Development Directorate
EMF	electromotive force
ft	foot (feet)
GSE	ground support equipment
in	inch
JSC	Lyndon B. Johnson Space Center
KSC	John F. Kennedy Space Center
ksi	kips (2000 lbs) per square inch
lbs	pounds
MIL	military
mm	millimeter
MPa	megapascal
MSC	Manned Spacecraft Center
MSFC	George C. Marshall Space Flight Center
NAS	National Aerospace Standard
NASA	National Aeronautics and Space Administration
SPEC	specification
STD	standard
TM	technical manual
UTS	ultimate tensile strength
∅	diameter
°C	degree Celsius
°F	degree Fahrenheit

QUICK RELEASE PINS AND PIN TETHERS,
STANDARD FOR

1. SCOPE

This standard covers the usage and installation of quick release pins and pin tethers on ground support equipment (GSE) and facilities at the John F. Kennedy Space Center (KSC) or areas under KSC responsibility. This standard identifies types of pins, materials approved for use, and installation methods to provide designers, engineers, and technicians with standard practices to ensure the proper use of pins.

This standard applies to facilities and GSE where hazards to flight hardware or personnel exist. Hazardous areas include the vicinity of flight hardware, launch environments, and at heights where a falling object might cause injury to personnel or damage to flight hardware. Work authorization documents prepared for technicians to install or replace quick release pins shall cite this standard and provide applicable sections.

2. APPLICABLE DOCUMENTS

The following documents form a part of this document to the extent specified herein. When this document is used for procurement, including solicitations, or is added to an existing contract, the specific revision levels, amendments, and approval dates of said documents shall be specified in an attachment to the Solicitation/Statement of Work/Contract.

2.1 Governmental.

2.1.1 Specifications.

John F. Kennedy Space Center (KSC), NASA

80K54867

Quick Release Pin, Specification for

80K56817

Tab, Quick Release Pin, Specification for

Military

MIL-P-23460

Pin, Quick Release, Self-Retaining, Positive-Locking

STD-P-0006
h 20, 1995

MIL-P-45952	Pin, Quick Release, Detent, General Specification for
MIL-W-83420/4	Wire Rope, Flexible, Type II (Jacketed) Composition B

Standards.

Federal

MS14274	Pin, Quick Release, Positive Locking, "L" Handle, Single Action, Detent Wrench/Safety Pin (Slotted)
MS17984	Pin, Quick Release, Self-Retaining, Positive Locking, Single Acting, Button Handle
MS17985	Pin, Quick Release, Self-Retaining, Positive Locking, Single Acting, "T" Handle
MS17986	Pin, Quick Release, Self-Retaining, Positive Locking, Single Acting, "L" Handle
MS17987	Pin, Quick Release, Self-Retaining, Positive Locking, Single Acting, Ring Handle
MS17988	Pin, Quick Release, Self-Retaining, Positive Locking, Double Acting, "T" Handle
MS17989	Pin, Quick Release, Self-Retaining, Positive Locking, Double Acting, "L" Handle
MS17990	Pin, Quick Release, Positive Locking, Double Acting, Ring Handle
MS51844	Sleeve, Swaging-Wire Rope

John F. Kennedy Space Center (KSC), NASA

KSC-STD-Z-0004	The Design of Structural Steel Buildings and Other Structures, Standard for
----------------	---

2.1.3 Other Documents.

John F. Kennedy Space Center (KSC), NASA

TM-584 Corrosion Control and Treatment Manual

Lyndon B. Johnson Space Center (JSC), NASA

125 MSC Design and Procedural Standard,
Cadmium-Restriction on Use

27 MSC Technical Information Bulletin, Use of
Cadmium Plated Tools on Titanium Hard-
ware

(Copies of specifications, standards, drawings, and publications required by suppliers in connection with specified procurement functions should be obtained from the procuring activity or as directed by the Contracting Officer.)

2.2 Non-Governmental.

NAS 1332 Pin, Quick Release, Positive Locking, Single
and Double Acting

NAS 1333 Pin, Quick Release, Positive Locking, Single
Acting

NAS 1353 Pin, Quick Release, Positive Locking, Dou-
ble Acting

(Non-Government standards and other publications are normally available from the organizations that prepare or distribute the documents. These documents also may be available in or through libraries or other informational services.)

2.3 Order of Precedence. - In the event of conflict between the documents referenced herein and the contents of this document, the contents of this document shall supersede except where otherwise noted. The NASA contract, purchase order, or program level documentation shall take precedence over the contents of this document in the event of conflicting requirements. Nothing in this document supersedes applicable laws and regulations unless a specific exemption has been obtained.

3. REQUIREMENTS

3.1 General. - Continuous problems with quick release pins and pin tethers established the need to provide designers, engineers, and technicians with standard practices to ensure their proper use and installation. The requirements and criteria specified herein shall be the minimum necessary to specify and install quick release pins and pin tethers. In the event more stringent requirements are necessary, they shall be determined by the responsible design organization in consultation with its customers. This standard applies to all designs with the following exceptions:

- a. Existing tethers shall be upgraded to meet this standard.
- b. When an existing pin is replaced for any reason, the replacement pin shall meet the requirements of this standard.

3.1.1 Facility Applicability. - This standard applies to all KSC facilities containing flight hardware or subjected to a launch environment and to areas where falling objects might cause injury to personnel.

3.1.2 GSE Applicability. - This standard applies to all GSE.

3.2 Types of Quick Release Pins.

3.2.1 Positive Locking, Single Acting Pins. - The locking device of single acting pins release the locking mechanism only by an axial push applied to the actuating button. The locking mechanism consists of 2 balls (standard) or 4 balls. The standard handle styles are "L" handles, "T" handles, button handles, and ring handles.

3.2.2 Positive Locking, Double Acting Pins. - The locking device of double acting pins release the locking mechanism when the spindle has been moved to a release position by an axial push or pull on the actuating button. The locking mechanism consists of 2 balls (standard) or 4 balls. The standard handle styles are "L" handles, "T" handles, button handles, and ring handles.

3.2.3 Detent Pins. - Detent pins contain spring loaded balls which are not positive locking. The pin is pushed to insert and pulled to remove. The pins contain 1 ball or 2 balls (standard). The standard handle styles are "L" handles, "T" handles, and ring handles.

3.2.4 Tethers. - Tethers are also referred to as lanyards or cable assemblies. Tethers are used to attach pins to adjacent structures to prevent loss and to prevent pins from becoming falling objects.

3.3 Materials.

3.3.1 Pin Materials. - Many component parts of both commercial quality and military standard pins do not meet the requirement to be highly resistant to stress corrosion cracking in accordance with KSC-STD-Z-0004 (see appendix A). The pin shank can be replaced with materials which are highly resistant to stress corrosion cracking on an economically feasible basis. The pin shank is usually the only critical component and this standard provides a means for bringing the shank into compliance when replacement of the pin is necessary. Existing pins not meeting this requirement may remain in service until replacement is required.

3.3.1.1 Alloy Steel. - Shanks of alloy steel pins shall conform to MIL-P-23460 or, if commercial pins are used, the shank shall be fabricated from an alloy that is highly resistant to stress corrosion cracking per KSC-STD-Z-0004 (see appendix A). See 80K54867 for requirements.

3.3.1.2 Corrosion Resistant Steel. - Shanks of stainless steel pins shall be fabricated from corrosion resistant steel that is highly resistant to stress corrosion cracking per KSC-STD-Z-0004 (see appendix A). See 80K54867 for requirements.

3.3.2 Tether Materials. - Tether cable shall be corrosion resistant steel per MIL-W-83420/4, type II, composition B. In noncorrosive environments, cable shall also be vinyl covered. In corrosive environments, cable shall not be covered so that the cable may be more easily inspected and also because a covering would promote wicking of corrosive substances inside the covering. Swage fittings shall be either MS51844 or a similar commercially available fitting. The minimum cable size shall be 1.588 mm (1/16 in) wire diameter and 2.381 mm (3/32 in) outside diameter (includes plastic coating). See figure 1 for other tether sizes.

3.4 Protective Finishes.

3.4.1 Alloy Steel. - Alloy steel shall be zinc (preferred) or cadmium plated. Cadmium plating shall not be used under the following conditions which are in accordance with MSC Design and Procedural Standard 125 and MSC Technical Information Bulletin 27 (see appendix B):

- a. Where cadmium plating or flakes from the plating could come in contact with titanium alloys.

Maximum Allowable Grip Lengths [mm (inches)] Per Cable Size

Pin Diameter [mm (inches)]	Cable Per MIL-W-83420/4			
	-002	-003	-004	-005
4.8 - 14.3 (3/16 - 9/16)	305 (12)			
15.9 (5/8)	249 (9.8)	305 (12)		
19.0 (3/4)	178 (7)	239 (9.4)	305 (12)	
22.2 (7/8)	119 (4.7)	163 (6.4)	305 (12)	
25.4 (1)	79 (3.1)	114 (4.5)	305 (12)	

Example: A 6.4-mm (1/4-in) diameter quick release pin with a grip length of 254 mm (10 in) can be attached with a MIL-W-83420/4-002 through MIL-W-83420/4-004 cable.

Example: A 22.2-mm (7/8-in) diameter quick release pin with a grip length of 127 mm (5 in) can be attached with a MIL-W-83420/4-003 through MIL-W-83420/4-005 cable.

Dash Numbers and Dimensions of Tethers

Part Number MIL-W-83420/4	ϕ D Cable Diameter [mm (inch)]	ϕ A Outside Diameter of Jacket [mm (inch)]	Type of Construction	Breaking Strength [kN (lbs)]	Length Per Reel [m (ft)]
-002	1.6 (1/16)	2.4 (3/32)	7 x 7	2.14 (480)	305 (1,000)
-003	2.4 (3/32)	3.2 (1/8)	7 x 7	4.09 (920)	30.5 (100)
-004	2.4 (3/32)	3.2 (1/8)	7 x 19	4.09 (920)	305 (1,000)
-005	4.8 (3/16)	6.4 (1/4)	7 x 19	16.46 (3,700)	305 (1,000)

Reference: Specification MIL-W-83420/4

Figure 1. Tether Sizes

- b. In applications where the temperature of the cadmium plating could exceed 232 degrees Celsius (°C) [450 degrees Fahrenheit (°F)].
- c. In the vicinity of and over payloads.

3.4.2 Corrosion Resistant Steel. - Corrosion resistant steel shall be passivated.

3.5 Pin Usage.

3.5.1 Controlled Environments. - Passivated stainless steel and zinc plated alloy steel pins are allowed for use in controlled environments. Cadmium plated pins are restricted as outlined in 3.4.1.

3.5.2 Launch Environment. - Passivated stainless steel is allowed for use in launch environments. Zinc and cadmium plated pins should be avoided. Dissimilar metals should be taken into consideration.

3.5.3 Uncontrolled Environments. - Passivated stainless steel is allowed for use in uncontrolled environments. Zinc and cadmium plated alloy steel pins should be avoided.

3.6 Pin Characteristics.

3.6.1 Pin Handles Permitted. - The following is a list of pin handle styles permitted and the conditions for their use:

a. Single Acting Pins:

- (1) "L" or "T" Handle (see figure 2) -
Replace split ring with swaged tether.
- (2) Button Handle (see figure 3) -
Replace link or ring with swaged tether.

b. Double Acting Pins:

- (1) "L" or "T" Handle with solid handle (not hollow) (see figure 4) -
Replace link or ring with swaged tether.

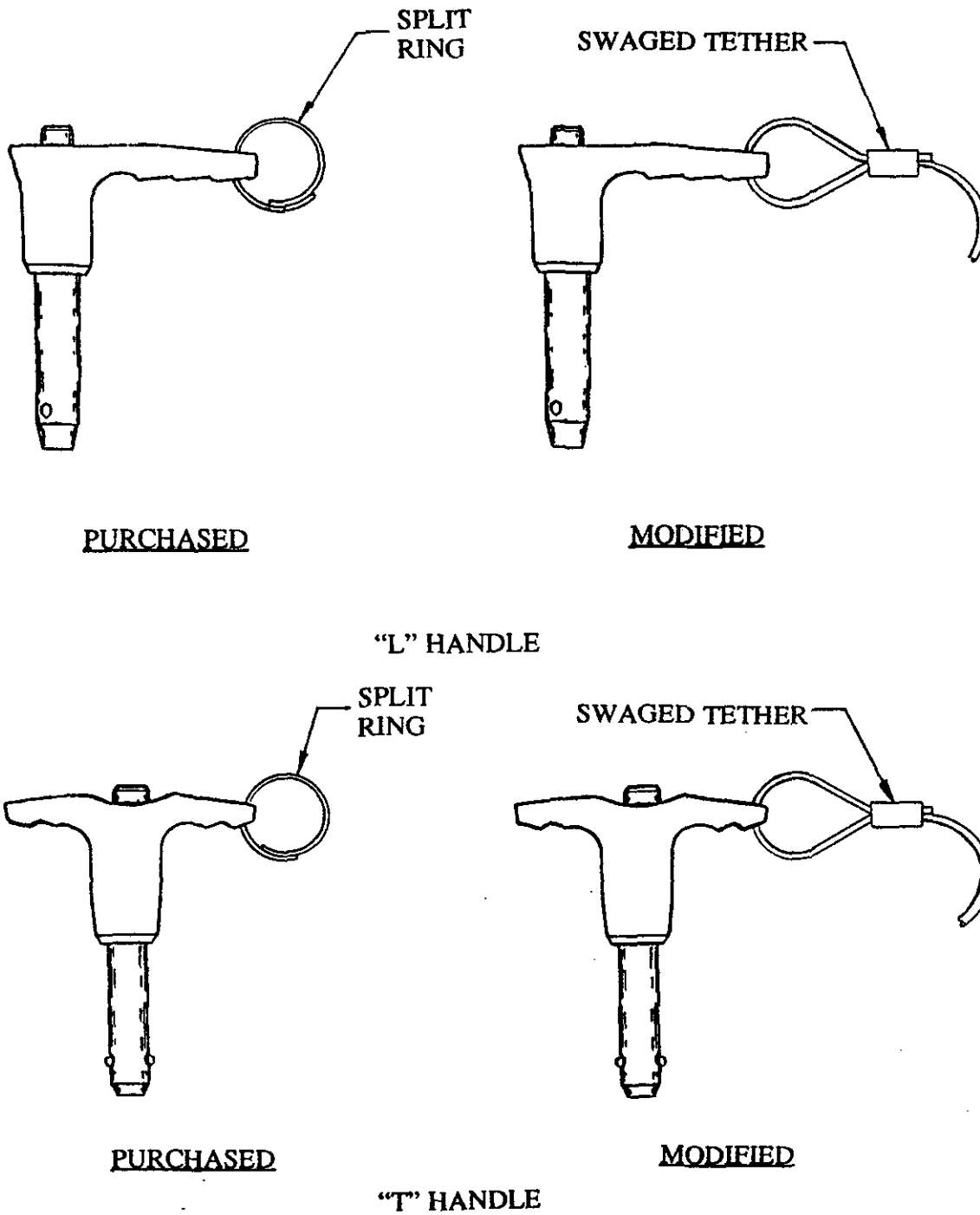
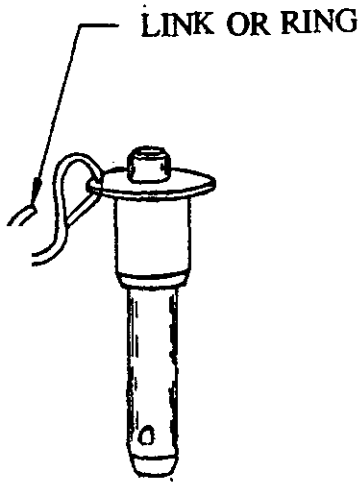
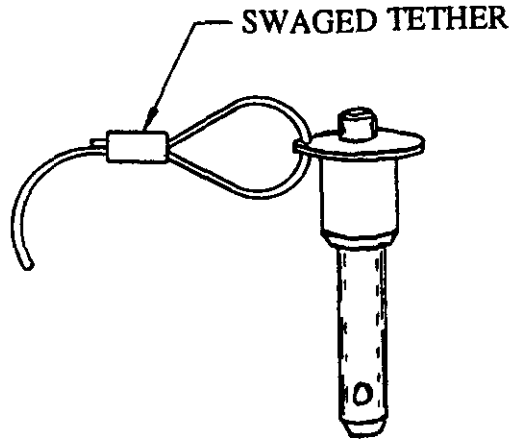

Figure 2. Single Acting Quick Release Pins, "L" and "T" Handles



PURCHASED



MODIFIED

BUTTON HANDLE

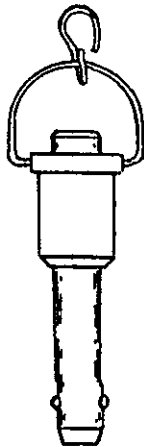

UNACCEPTABLE

DO NOT USE

RING HANDLE

1. Single Acting Quick Release Pins, Button and Ring Handles

NOTE: ROLL PIN "L" OR "T" HANDLES NOT ALLOWED

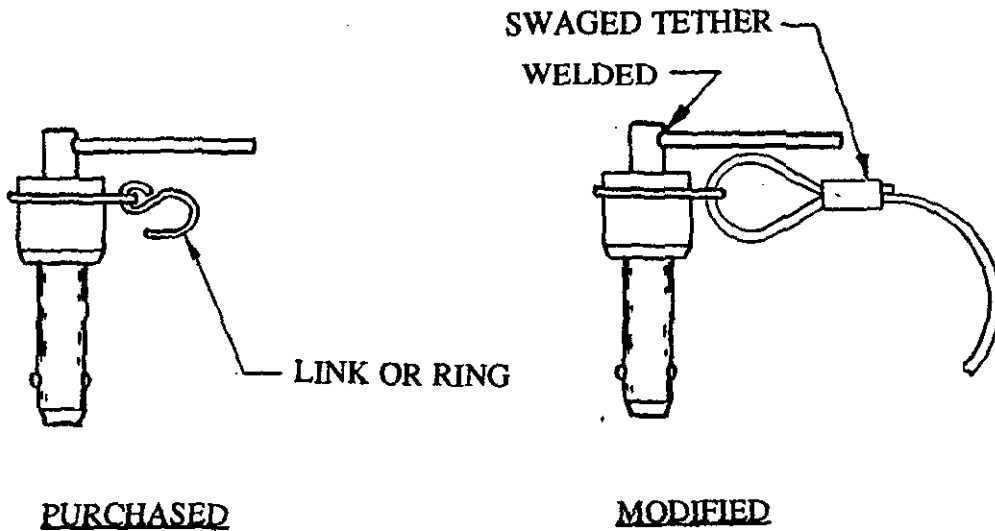

"L" HANDLE

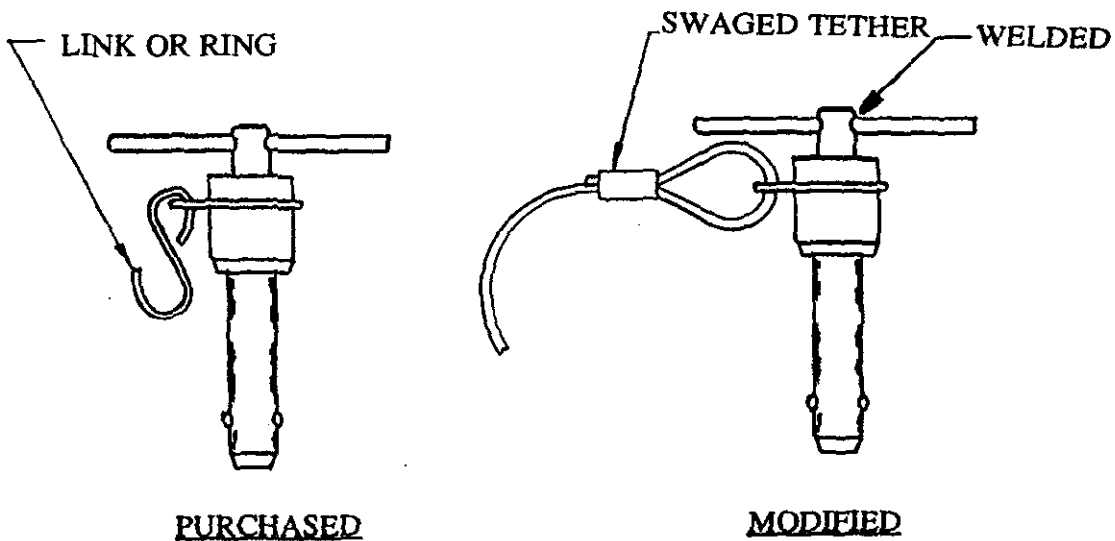

"T" HANDLE

Figure 4. Double Acting Quick Release Pins, "L" and "T" Handles

- (2) Ring Handle (see figure 5) -
Replace music wire ring handle with a swaged wire rope ring.
Replace link with swaged tether. These pins should be avoided where inadvertent actuation by snagging the ring could cause accidental release of the pin.
- c. Detent Pins:
- (1) "L" or "T" Handle with solid handle (not hollow) (see figure 6) -
Replace link or ring with swaged tether.
 - (2) Ring Handle (see figure 7) -
Replace music wire ring handle with a swaged wire rope ring. Add swaged tether to ring. These pins should be avoided where inadvertent actuation by snagging the ring could cause accidental release of the pin.

3.6.2 Pin Handles Not Permitted. - The following list identifies pin handle styles which are not permitted for use:

- a. Single Acting Pins: Ring Handle (see figure 3) -
This ring handle style, also called a "C" or "D" type handle, can spread open, separating the tether from the pin, and allowing the pin to fall.
- b. Double Acting Pins: Roll Pin "L" or "T" Handle (see figure 4) -
Roll pins are hollow pins which are pressed into the head of the pin. Internal corrosion can weaken the roll pin causing it to break upon actuation.
- c. Detent Pins: Roll Pin "L" or "T" Handle (see figure 6) -
Roll pins are hollow pins which are pressed into the head of the pin. Internal corrosion can weaken the roll pin causing it to break upon actuation.

3.6.3 Pin Lengths. - Many design drawings specify nonstandard lengths which require long lead times. When the next longer standard length can be used in an application, and will not affect the function of the installation, the pin may be replaced without approval from design engineering. This standard will supersede the drawing. No drawing change is required.

3.6.4 Pin Diameters. - Any proposed change in pin diameters will require approval from design engineering.

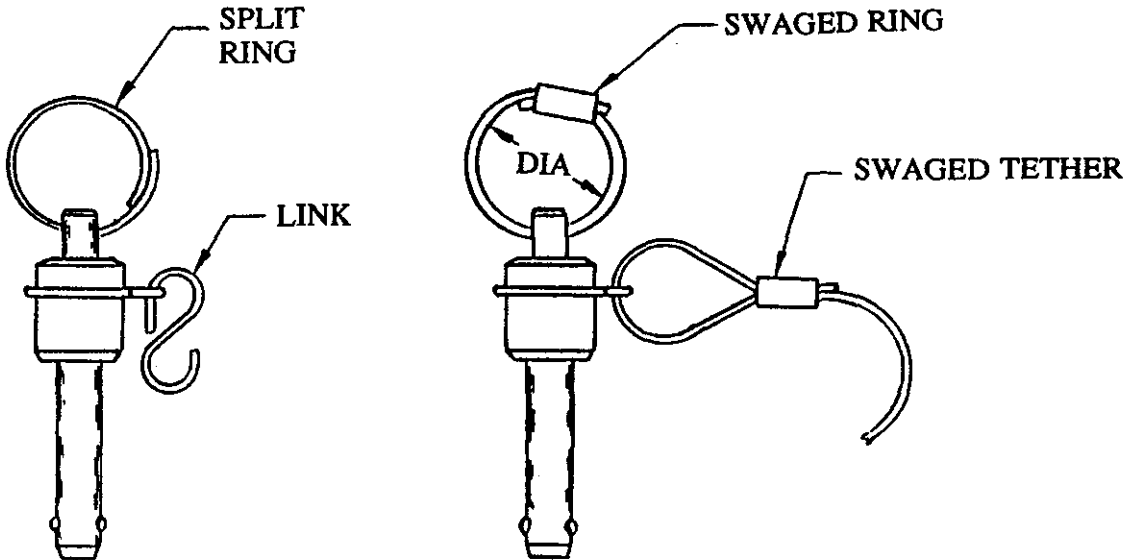

PURCHASED

MODIFIED

RING HANDLE

Tabulation		
Pin Diameter [mm (inch)]	"Diameter" (Min) (inches)	"Diameter" (Min) (millimeters)
4.8 - 12.7 (3/16 - 1/2)	1.00	25.4
14.3 - 15.9 (9/16 - 5/8)	1.50	38.1
19.1 - 25.4 (3/4 - 1)	2.00	50.8

Figure 5. Double Acting Quick Release Pins, Ring Handle

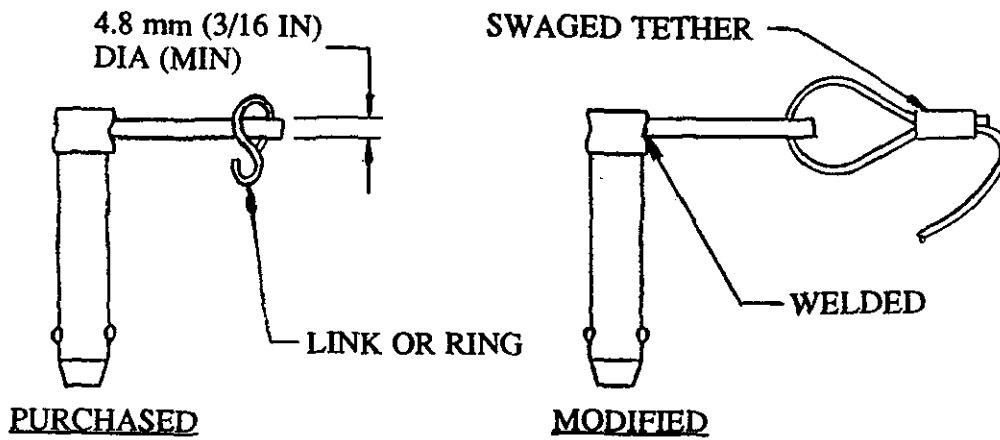

"L" HANDLE

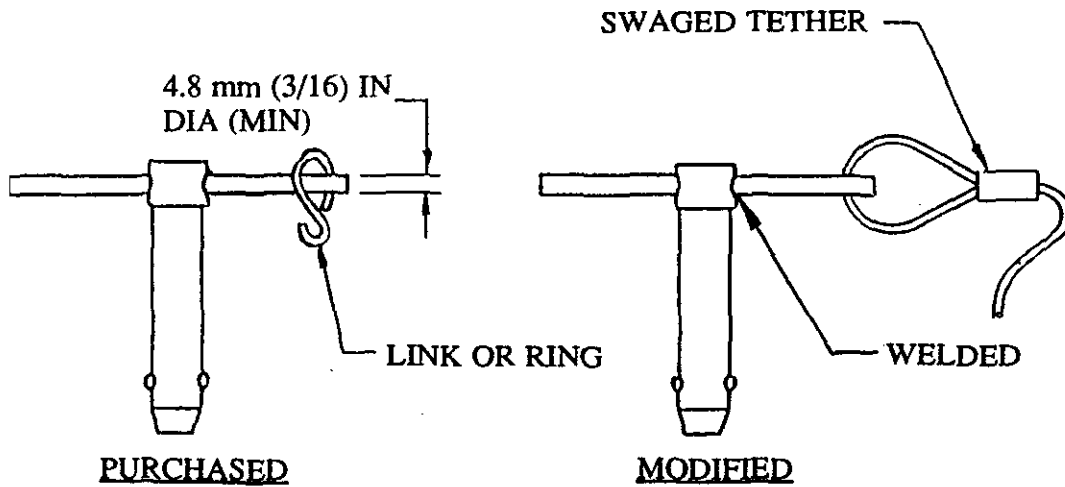

"T" HANDLE

NOTE: ROLL PIN "L" OR "T" HANDLES NOT ALLOWED

Figure 6. Detent Pin, Quick Release, "L" and "T" Handles

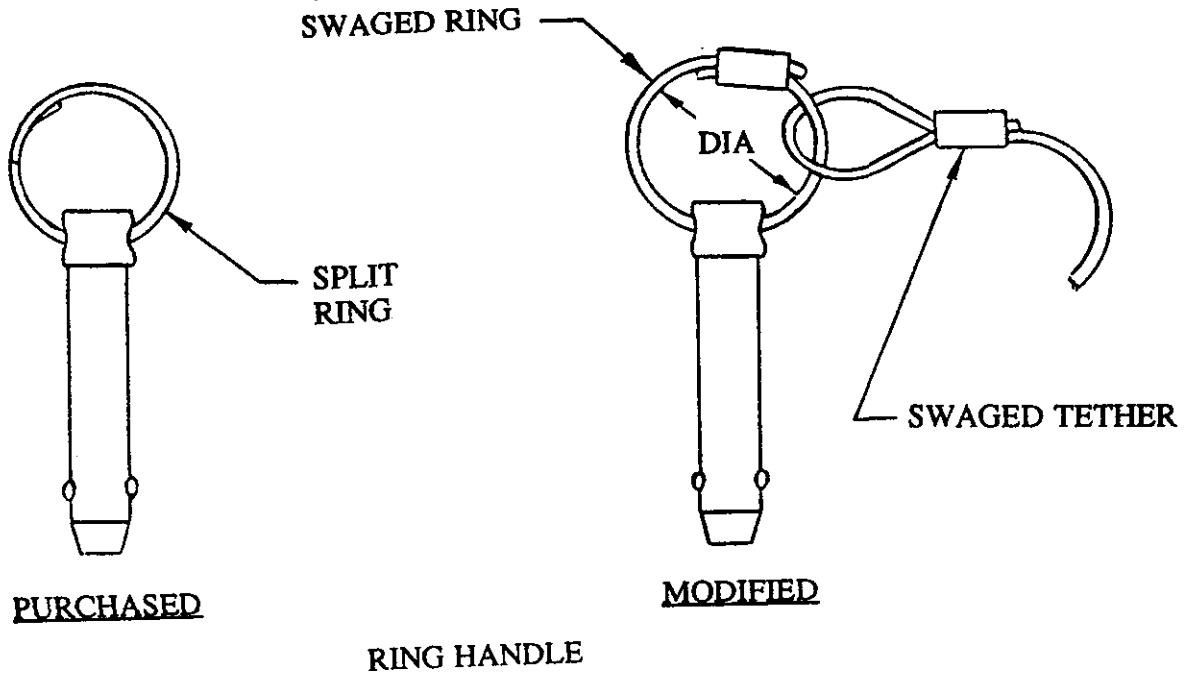

Tabulation		
Pin Diameter [mm (inch)]	"Diameter" (Min) (inches)	"Diameter" (Min) (millimeters)
4.8 - 12.7 (3/16 - 1/2)	1.00	25.4
14.3 - 15.9 (9/16 - 5/8)	1.50	38.1
19.1 - 25.4 (3/4 - 1)	2.00	50.8

Figure 7. Detent Pin, Quick Release, Ring Handle

3.6.5 Substitution of Pins.

3.6.5.1 Requiring Prior Engineering Approval.

- a. Replacing positive locking pins with detent pins.
- b. Replacing corrosion resistant steel pins with steel pins in an uncontrolled atmosphere or launch environment.
- c. Changing to a cadmium plated pin in the vicinity of flight hardware or in a launch environment.
- d. When design drawings state "no substitutions permitted."

3.6.5.2 Not Requiring Engineering Approval.

- a. Replacing detent pins with positive locking pins conforming to this standard.
- b. Changing cadmium plating to zinc plating.
- c. Changing handle styles as long as pins conform to this standard.

3.7 Tether Installation.

3.7.1 Pin Preparation. - Attachment links, rings, and ring handles supplied by the manufacturer shall be removed and scrapped unless they conform to the configurations shown in figures 2 through 7.

3.7.2 Tether Attachment to Pin. - Tether attachments to pins shall be as shown in figures 2 through 7. Tether diameters shall increase with larger, heavier pins. See figure 1 for tether sizes. The standard tether length shall be between 250 to 300 mm (10 to 12 in), but shorter or longer lengths may be necessary depending on the application. Tether length shall be the minimum slack required to perform the intended function.

3.7.3 Ring Handle Replacement. - The music wire split ring on ring handle double acting pins and ring handle detent pins shall be replaced with a swaged wire rope ring as shown in figures 5 and 7.

3.7.4 Tether Attachment to Structure. - Acceptable terminations of tethers to structure are shown in figures 8 and 9.

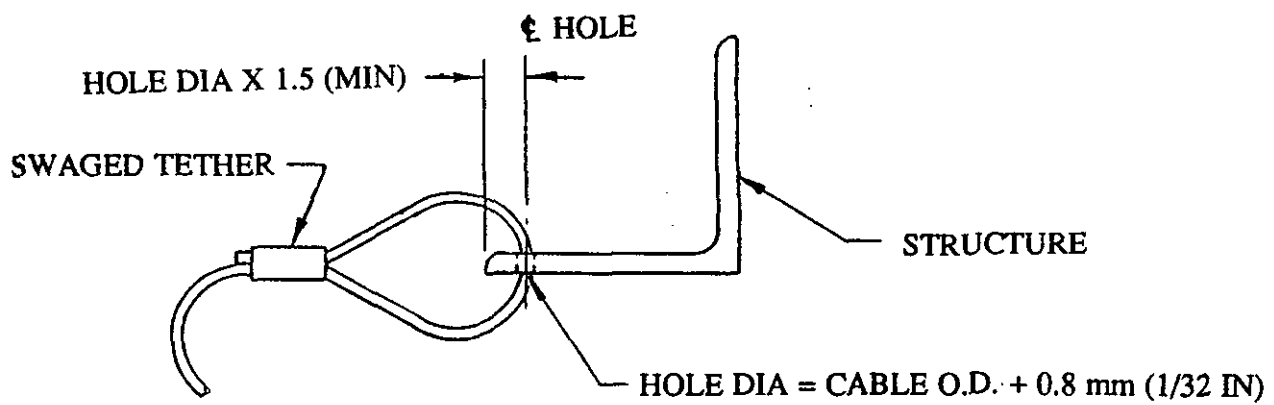

DIRECT TERMINATION - STRAIGHT

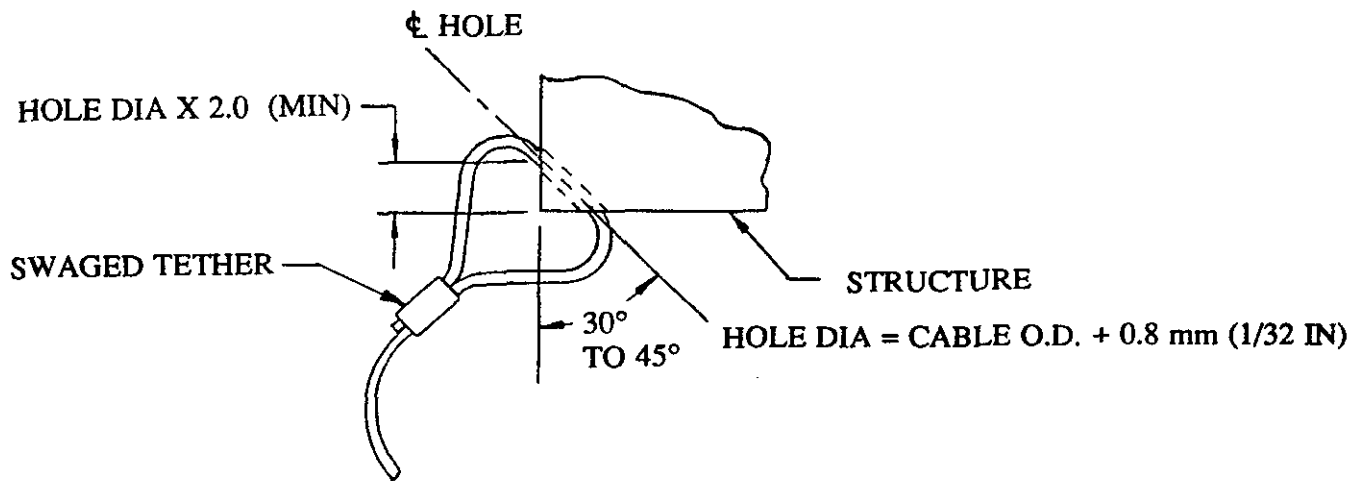

DIRECT TERMINATION - ANGLED

Figure 8. Tether Attachments to Structure, Direct Termination

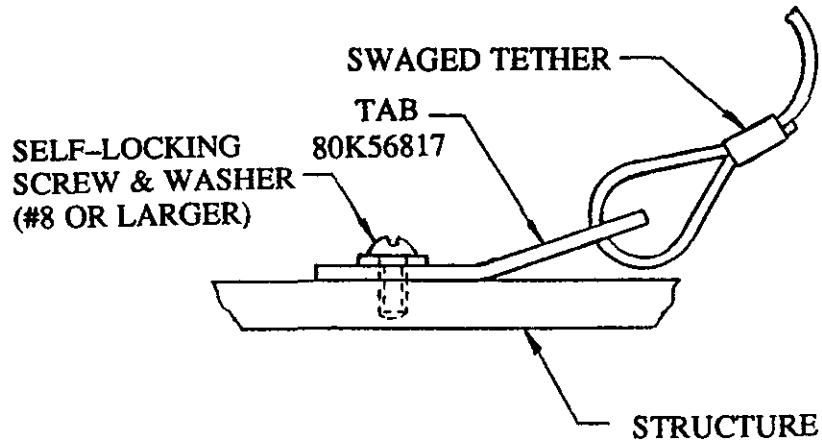

TAB TERMINATION

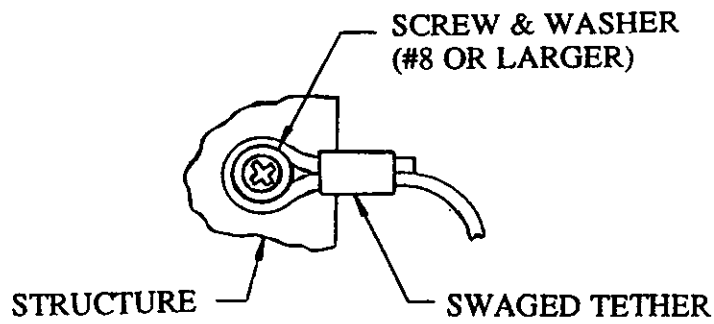

SCREW TERMINATION
FOR EXISTING DESIGNS

Figure 9. Tether Attachments to Structure, Tab Termination

3.7.5 Tether Attachment Hardware. - Attachment screws and washers shall be no. 8 or larger and the material shall have a high resistance to stress corrosion cracking per KSC-STD-Z-0004 (see appendix A). Sheet metal screws shall not be used to secure tethers. Tabs shall be in accordance with figure 9.

3.8 Design.

3.8.1 Design Drawings. - This standard shall be referenced on new drawings when quick release pins are specified. The pins shall be specified on the drawing describing the type of pin, part number, and manufacturer or specification. Details of lanyard installations are not required unless special considerations not covered by this standard are necessary. When substitutions are not permitted, the design drawing shall state "no substitutions permitted." The standard shall be referenced on existing drawings when they are updated for other reasons.

3.8.2 Design Considerations. - Design engineering shall consider all criteria covered by this standard. Design shall also consider the following:

- a. Storage of pins when not in use.
- b. Pinch points, where tethers could be damaged, shall be avoided.
- c. Single shear and tension applications shall be avoided in load carrying applications.
- d. Standard lengths should be used when possible. Tolerance stack-up shall be addressed to ensure adequate grip lengths of pins.
- e. In low stress applications, the entrance hole may be slightly larger than the ball engagement hole to aid in assembly and disassembly.
- f. If a tether can be attached to a critical part which could be degraded by drilling, design shall provide for tether attachment.
- g. Avoid tripping or snag hazards from lanyards.
- h. Quick release pins should be limited to routinely removed items.

4. QUALITY ASSURANCE PROVISIONS

The quality surveillance organization having cognizance over the installation of quick release pins and pin tethers shall perform inspections to ensure that they conform to the requirements of this standard.

5. PREPARATION FOR DELIVERY

Not applicable.

6. NOTES

6.1 Intended Use. - This document is intended to be used to standardize the usage and installation of quick release pins and pin tethers in the vicinity of flight hardware, launch environments, and at heights.

6.2 Definitions. - For the purposes of this standard the following definitions shall apply:

6.2.1 Controlled Environment. - Those spaces within a building or facility where the air is controlled and/or conditioned, heated, cooled, or humidity controlled.

6.2.2 Deviation. - A specific authorization granted before the fact to depart from a particular requirement of the specifications or design drawings.

6.2.3 Dissimilar Metals. - Two metals or alloys that have different electromotive force (EMF) characteristics and which when in contact with or in the presence of an electrolyte will result in the accelerated corrosion of the more active dissimilar metal or alloy.

6.2.4 Stress Corrosion Cracking. - Spontaneous cracking produced by the combined action of corrosion and static residual or applied stress. For this phenomenon to occur, stress and corrosion acting together must lead to greater damage than if they acted separately.

6.2.5 Uncontrolled Environment. - Those places where the air is not conditioned or controlled and is not in the direct launch environment, where it is subject to abrasion or temperatures exceeding 232 °C.

NOTICE. The Government drawings, specifications, and/or data are prepared for the official use by, or on the behalf of, the United States Government. The Government neither warrants these Government drawings, specifications, or other data, nor assumes any responsibility or obligation, for their use for purposes other than the Government project for which they were prepared and/or provided by the Government, or an activity directly related thereto. The fact that the Government may have formulated, furnished, or in any way supplied the said drawings,

SC-STD-P-0006

March 20, 1995

specifications, or other data is not to be regarded, by implication or otherwise, as
conveying in any manner the holder or any other person or corporation, nor
conveying the right or permission, to manufacture, use, or sell any patented
invention that may relate thereto.

Custodian:

ASA - John F. Kennedy Space Center
Kennedy Space Center, Florida 32899

Preparing Activity:

John F. Kennedy Space Center
Mechanical Engineering Division
Engineering Development Directorate

APPENDIX A
ALLOYS WITH HIGH RESISTANCE TO STRESS CORROSION CRACKING

<u>Steel Alloys</u>	<u>Condition</u>
AISI 10XX series carbon steels	< 1240 MPa (180 ksi) UTS
AISI 41XX, 43XX, D6AC, etc., low-alloy steels	< 1240 MPa (180 ksi) UTS
ASTM A228 music wire	Cold drawn
AISI 1095 spring steel	Tempered
HY80, HY130, HY140	Tempered
ASP 11	Aged
Nitronic 32/33/40	Annealed
AM350/355 stainless	SCT 1000 and above
AM362 stainless	3 hours at 540 °C (1,000 °F)
ARMCO A286 stainless	All
Carpenter 20 Cb/20 Cb-3 stainless	All
Custom 450/455	H1000 and above
PH 15-7 Mo stainless	CH900
15-5 PH stainless	H1000 and above
17-7 PH stainless	CH900
AISI 200 series stainless	All (unsensitized)
AISI 300 series stainless (except free machining grades)	Annealed (unsensitized)*
AISI 434/436/446 stainless	All

<u>Aluminum Alloys</u>	<u>Condition</u>
AA 1000 series	All
AA 2219	T6, T8
AA 2618	T6
AA 3000 series	All
AA 6061	0, T6, T6XXX
AA 7050, AA 7149, AA 7475	T73
AA 333.0, AA A333.0	As cast
AA 357.0, AA B358.0, AA 359.0	All
AA 380.0, AA A380.0	As cast
AA 514.0, AA 518.0, AA 535.0**	As cast
AA A712.0, AA C712.0	As cast

* If certain sections of annealed AISI 300 series components are cold worked to produce flares, etc., then these areas are highly susceptible to stress corrosion cracking and should be properly coated and maintained.

** Aluminum alloys with magnesium content greater than 3 percent should not be used in applications greater than or equal to 65 degrees Celsius (150 degrees Fahrenheit).

-STD-P-0006
March 20, 1995

Nickel Alloys

Alloy 800/825/901/903
Inconel 600/625
Inconel 718/X-750
Alloy B
Alloy C/X
Inconel 52 CR
Alloy 36
Alloy K-500
Inconel-C 902
Alloy 1
Alloy Inp 212
Alloy

Condition

All
Annealed
All
Solution treated
All
All
All
All
All
All
All
All

APPENDIX B

RESTRICTIONS ON THE USE OF CADMIUM PLATING

NASA . Manned Spacecraft Center

**MSC
DESIGN AND PROCEDURAL
STANDARD**



TITLE Cadmium -- Restriction on Use	STANDARD NO.	PAGE
	125	1 of 2
	EFFECTIVE DATE	
	March 6, 1970	
	REVISION DATE	REVISION DATE
	REVISION DATE	REVISION DATE

STATEMENT OF STANDARD

Use of cadmium and cadmium plating should be avoided under the following conditions:

1. Where cadmium in contact with breathing gas could reach temperatures that would generate toxic fumes.
2. In equipment containers where electrical and electronic equipment could be degraded to an unacceptable level by vaporization and deposition of cadmium on the equipment surfaces.
3. In applications where the combination of temperature and proximity of the cadmium or cadmium plating could adversely affect critical surfaces by cadmium deposition. Critical surfaces include, but are not limited to, optical surfaces, electromagnetic radiating surfaces, and surfaces that have specified requirements for solar radiation absorptivity or total hemispheric emissivity.
4. In applications where temperature of the cadmium or cadmium plating could exceed 450 °F.

REMARKS

Cadmium is prone to vaporize rapidly at combinations of temperature and pressure encountered in space flight applications. The fumes are toxic and may cause problems if redeposited on certain equipment surfaces.

A sharp decrease in the tensile strength of cadmium-plated, high-strength steel parts can occur when the parts are subjected to elevated temperatures while under stress. Embrittlement occurs as a result of diffusion of cadmium into the alloy – a process that progresses rapidly at temperatures above 450 °F. Under such conditions, failures have occurred at loads corresponding to
(See page 2.)

NASA . Manned Spacecraft Center
MSC DESIGN AND PROCEDURAL STANDARD

TITLE	STANDARD NO.	PAGE
Cadmium - Restrictions on Use	125	2 of 2
<p>stresses well below the tensile strength of the steel. Cadmium-plated tools should not be used on titanium or high-strength steel parts that are to be operated under stress at temperatures above 450 °F, since small deposits of cadmium may be left on the part.</p> <p>Breathable atmospheres could become severely toxic with cadmium fumes if a cadmium or cadmium-plated part was overheated. Overheating could result from an electrical short circuit, a fire, or from dissipated electrical power in a component installed with a cadmium-plated fastener. The toxic effect is cumulative and continued breathing of a very low concentration of cadmium fumes may result in prolonged disability, or possibly death. The presence of low concentrations of cadmium fumes may not be detected until toxic effects are felt. Venting the crew compartment to outside atmosphere or space would provide only a temporary reduction in cadmium concentration unless the supply of cadmium was depleted or the source of heat eliminated. The use of an organic-based paint as a barrier overcoating of cadmium surfaces is not a reliable method of control because of porosity of the available overcoatings and possibility of overcoating damage during normal operations. Complete elimination of cadmium from areas exposed directly to breathable atmospheres appears to be the most practical method of avoiding the toxicity hazards involved in cadmium use.</p>		
<p>The requirement set forth in this standard is Center Policy. The requirement applies to all equipment developed for operation in space by the Manned Spacecraft Center. Application to ground equipment is not required unless specifically indicated in the statement of standard. Establishment of the Manned Spacecraft Criteria and Standards Program, standards, and policies of application, and compliance are described in MSC1 8080.7</p>		<p>APPROVAL  MSC DIRECTOR</p>

MSC Form 1010E (Rev. July 89)

NASA . Manned Spacecraft Center
MSC CRITERIA AND STANDARDS PROGRAM

TECHNICAL INFORMATION BULLETIN

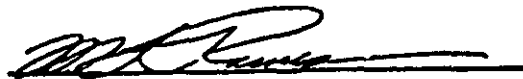

SUBJECT Use of Cadmium Plated Tools on Titanium Hardware	BULLETIN NO. 27	PAGE 1
DATE December 1975		
<p>Recent discoveries of the use of cadmium plated tools on titanium fittings indicate the need to emphasize the hazards associated with the use of cadmium plated tools on titanium hardware. Cadmium plated tools used on titanium parts deposit small amounts of cadmium on the part causing surface cracking of the titanium at high tensile stress. The number and depth of cracks increase with temperature.</p> <p>The Manned Spacecraft Criteria and Standards, Design and Procedural Standard No. 125, "Cadmium - Restriction on Use," forbids the use of cadmium plated tools on titanium parts to be operated under stress at temperatures above 450 °F. Recent investigations indicate that the critical temperature could be as low as 200 °F.</p> <p>This information bulletin is to emphasize that cadmium plated tools shall not be used on titanium lines and fittings.</p> <p>REFERENCE:</p> <ol style="list-style-type: none">1. Manned Spacecraft Criteria and Standards JSCM 8080, Design and Procedural Standard No. 125, Cadmium - Restrictions on Use, Dated March 6, 1970.2. Letter from Defense Supply Agency, CDRL-DLQR, Cadmium Contamination of Titanium and Titanium Alloys, Dated October 7, 1975.3. Initiated by the Reliability Division, Safety, Reliability and Quality Assurance Office, Johnson Spacecraft Center.		
This bulletin contains information that may affect the design, development, and operation of equipment related to space-flight. Immediate review of the information is recommended. Action is at the discretion of the recipient. The MSC Criteria and Standards Program is described in MSC 8080.2.		

STANDARDIZATION DOCUMENT IMPROVEMENT PROPOSAL

INSTRUCTIONS

1. The preparing activity must complete blocks 1, 2, 3, and 8. In block 1, both the document number and revision letter should be given.
2. The submitter of this form must complete blocks 4, 5, 6, and 7.
3. The preparing activity must provide a reply within 30 days from receipt of the form.

NOTE: This form may not be used to request copies of documents, nor to request waivers or clarification of requirements on current contracts. Comments submitted on this form do not constitute or imply authorization to waive any portion of the referenced document or to amend contractual requirements.

I RECOMMEND A CHANGE:

1. DOCUMENT NUMBER
KSC-STD-P-0006

2. DOCUMENT DATE
March 20, 1995

3. DOCUMENT TITLE

Quick Release Pins and Pin Tethers, Standard For

4. NATURE OF CHANGE (Identify paragraph number and include proposed rewrite, if possible. Attach extra sheets as needed.)

5. REASON FOR RECOMMENDATION

6. SUBMITTER

a. NAME (Last, First, Middle Initial)

b. ORGANIZATION

c. ADDRESS (Include Zip Code)

d. TELEPHONE (Include Area Code)

7. DATE SUBMITTED

8. PREPARING ACTIVITY

a. NAME

Director of Engineering Development

d. TELEPHONE (Include Area Code)

(407) 867-2565

c. ADDRESS (Include Zip Code)

National Aeronautics and Space Administration
Mail Code: DE
Kennedy Space Center, FL 32899